



United States Department of Agriculture

Synthesis of Knowledge of Extreme Fire Behavior:

Volume 2 for Fire Behavior Specialists, Researchers, and Meteorologists

Paul A. Werth, Brian E. Potter, Martin E. Alexander, Miguel G. Cruz,
Craig B. Clements, Mark A. Finney, Jason M. Forthofer, Scott L. Goodrick,
Chad Hoffman, W. Matt Jolly, Sara S. McAllister, Roger D. Ottmar, and
Russel A. Parsons



Forest
Service

Pacific Northwest
Research Station

General Technical Report
PNW-GTR-891

March
2016

Pacific Northwest Research Station

Web site	http://www.fs.fed.us/pnw
Telephone	(503) 808-2592
Publication requests	(503) 808-2138
FAX	(503) 808-2130
E-mail	pnw_pnwpubs@fs.fed.us
Mailing address	Publications Distribution Pacific Northwest Research Station P.O. Box 3890 Portland, OR 97208-3890

A SUMMARY OF KNOWLEDGE FROM THE



Authors

Paul A. Werth is a fire weather meteorologist (retired), Northwest Interagency Coordination Center, 150 SW Harrison Street, Suite 400, Portland, OR 97201. **Brian E. Potter** is a research meteorologist, U.S. Department of Agriculture, Forest Service, Pacific Wildland Fire Sciences Laboratory, 400 N 34th St., Suite 201, Seattle, WA 98103. **Martin E. Alexander** is an adjunct professor of wildland management, Department of Renewable Resources and Alberta School of Forest Science and Management, University of Alberta, Edmonton, AB T6G 2H1, Canada. **Craig B. Clements** is an assistant professor of meteorology, San Jose State University, San Jose, CA 95192. **Miguel G. Cruz** is a senior research scientist, Bush Fire Dynamics and Applications, CSIRO Ecosystems Sciences—Climate Adaptation Flagship, GPO Box 284, Canberra, ACT 2601, Australia. **Mark A. Finney** is a research forester, **Jason M. Forthofer** is a mechanical engineer, **W. Matt Jolly** is an ecologist, **Sara S. McAllister** is a research mechanical engineer, and **Russel A. Parsons** is a research ecologist, 5775 US West Highway 10, Missoula, MT 59808. **Scott L. Goodrick** is a research meteorologist, U.S. Department of Agriculture, Forest Service, Southern Research Station, 320 Green Street, Athens, GA 30602. **Chad Hoffman** is an instructor, Wildland Fire Program, College of Natural Resources, University of Idaho, Moscow, ID 83844. **Roger D. Ottmar** is a research forester, U.S. Department of Agriculture, Forest Service, Pacific Wildland Fire Sciences Laboratory, 400 N 34th St., Suite 201, Seattle, WA 98103. (Werth and Potter were lead co-authors on this project. Other authors are listed alphabetically per location.)

Funding for the printing of this volume was provided by the Joint Fire Science Program Project 09-5-03-1.

The use of trade or firm names in this publication is for reader information and does not imply endorsement by the U.S. Department of Agriculture of any product or service.

Abstract

Werth, Paul A.; Potter, Brian E.; Alexander, Martin E.; Clements, Craig B.; Cruz, Miguel G.; Finney, Mark A.; Forthofer, Jason M.; Goodrick, Scott L.; Hoffman, Chad; Jolly, W. Matt; McAllister, Sara S.; Ottmar, Roger D.; Parsons, Russell A. 2016. Synthesis of knowledge of extreme fire behavior: volume 2 for fire behavior specialists, researchers, and meteorologists. Gen. Tech. Rep. PNW-GTR-891. Portland, OR: U.S. Department of Agriculture, Forest Service, Pacific Northwest Research Station. 258 p.

The National Wildfire Coordinating Group's definition of extreme fire behavior indicates a level of fire behavior characteristics that ordinarily precludes methods of direct control action. One or more of the following is usually involved: high rate of spread, prolific crown-ing/spotting, presence of fire whirls, and strong convection column. Predictability is difficult as such fires often influence their environment to some degree and behave erratically, sometimes dangerously. Alternate terms include "blow up" and "fire storm." Fire managers examining fires over the last 100 years have come to understand many of the factors necessary for extreme fire behavior development. This effort produced guidelines included in current firefighter training, which presents the current methods of predicting extreme fire behavior by using the crown fire model, which is based on the environmental influences of weather, fuels, and topography.

Current training does not include the full extent of scientific understanding nor does it include the most recent scientific knowledge. National Fire Plan funds and the Joint Fire Science Program have sponsored newer research related to wind profiles' influence on fire behavior, plume growth, crown fires, fire dynamics in live fuels, and conditions associated with vortex development. Of significant concern is that characteristic features of extreme fire behavior depend on conditions undetectable on the ground, namely invisible properties such as wind shear or atmospheric stability.

No one completely understands all the factors contributing to extreme fire behavior because of gaps in our knowledge. These gaps, as well as the limitations as to when various models or indices apply should be noted to avoid application where they are not appropriate or warranted. This synthesis summarizes existing extreme fire behavior knowledge. It consists of two volumes. Volume 1 is for fire managers, firefighters, and others in the fire community who are not experts or specialists in fire behavior but need to understand the basics of extreme fire behavior. Volume 2 is more technical and is intended for fire behaviorists and fire researchers.

The objective of this project is to synthesize existing extreme fire behavior knowledge in a way that connects the weather, fuel, and topographic factors that contribute to development of extreme fire behavior. This synthesis focuses on the state of the science but also considers how that science is currently presented to the fire management community, including incident commanders, fire behavior analysts, incident meteorologists, National Weather Service office forecasters, and firefighters. The synthesis seeks to delineate the known, the unknown, and areas of research with the greatest potential impact on firefighter protection.

Keywords: Extreme fire behavior, fuels, fire behavior.

Preface

In 2008, the National Wildfire Coordinating Group (NWCG) Fire Behavior Committee (FBC) asked the Joint Fire Science Program (JFSP) to fund a synthesis and review of the scientific literature pertaining to extreme fire behavior. In September 2008, the JFSP announced a call for proposals that included a request for “an examination of the state of the science underlying predictions of extreme fire behavior, and an assessment of the appropriate uses and limits of this information.” This document is the result of that request.

In performing the review, it became progressively clearer that the concept of extreme fire behavior is vaguely defined and means something different to everyone. The authors examined the official NWCG definition and solicited input from the management community to develop a definition that was both operationally useful and scientifically tractable. This definition and the initial stages of the review eventually led to the recognition that some relevant topics had not been included in the original outline. Other topics from the original outline expanded to include sections of their own.

The authors communicated these changes to both the JFSP and the FBC as they arose. In those conversations, it became apparent that these two groups had different needs. The JFSP needed something for fire managers and others without the technical background of a fire behavior analyst. The FBC needed a document for fire behavior analysts that would allow them to better understand the use and limitations of the tools they now have and may have in the near future. To meet these two needs, this review has two parts. Volume 1 summarizes the state of the science for fire managers and firefighters with pertinent references to scientific papers. It is intended to be of use to anyone who works at or near the fire line. Volume 2 covers the same topics (with one exception) in more detail and includes information necessary for fire behavior analysts to understand what is scientifically known, what science lies behind the tools they have, and what the limitations are on scientific knowledge and tools. It includes more references to scientific literature. The one difference in topical content between the volumes is that volume 2 includes a chapter on fuel dynamics. As the study progressed, the scope of this topic led to the need to include more experts, and the short time available precluded that section from publication in volume 1.

Summary

A working definition of extreme fire behavior was necessary to develop this synthesis. Because the subjective nature of the National Wildfire Coordination Group’s definition of extreme fire behavior makes it intractable for scientific purposes, the

lead authors asked the fire behavior community for input on possible definitions of extreme fire behavior and examples of phenomena they considered extreme fire behavior. The only coherent theme was that extreme fire behavior is not steady state. After discussing responses, the authors agreed on the following working definition of extreme fire behavior: “Fire spread other than steady surface spread, especially when it involves rapid increases.” This definition does not emphasize any one element of the behavior triangle.

The state of the science at present can be summed up as follows:

- Fire is three dimensional and is not steady state.
- The tools available to us today are two dimensional and are predominantly steady state.
- Additional research into extreme fire behavior may one day result in development of three-dimensional tools.

Complexity

It is imperative that fire managers understand that much extreme fire behavior happens where it cannot be seen. Multiple factors come into play, and not all factors need be present for extreme fire behavior to occur, nor must one factor be present in every case. Extreme fire behavior can occur on any scale, great or small, in any fuel type, and at any time of the day or night. At no time or under any circumstance should fire managers assume that extreme fire behavior will not occur.

A number of interactions among the elements were noted previously; however, it should be noted that the number of possible interactions between elements are practically unlimited, making research and the resulting tool development a key step in achieving successful forest management and safety. The state of the science at present can be summed up as follows:

- Fire is three dimensional and is not steady state.
- The tools available to us today are two dimensional and are predominantly steady state.
- Additional research into extreme fire behavior may one day result in development of three-dimensional tools.

Overarching Gaps

The authors of this synthesis have identified areas in each chapter where understanding of the science is lacking and more research is needed. These knowledge gaps may pertain to just one chapter’s topic but are nonetheless important areas in

which further research would be of value to the operational community. However, there are also certain overarching gaps where additional research of one element would advance the science for other elements as well:

- A greater recognition of the importance of plume dynamics to extreme fire behavior and spotting.
- Advances in the understanding of fuel dynamics and structure, especially fuel moisture dynamics and the importance of fuel heterogeneity as it relates to fire intensity, ember production, and crown fire.
- Better high-resolution observations of windflow in complex terrain to improve wind models used in fire behavior and spotting tools, and to identify fire whirl potential (e.g., upper air soundings on project-size fires).
- The influence of ambient winds or topography on fire interactions.
- Research to quantify the effects of atmospheric stability on fire behavior and move beyond the Haines Index.

New and expanded research into these areas will increase the understanding of the science on which they are based and is a necessary starting point for enhanced wildland fire management and advances in firefighter training and safety.

Operational Implications

Even the most advanced tools and models are limited by their design and assumptions. They can never, nor should they be expected to, take the place of direct observations one makes on the fireline—the “L” in LCES (Lookouts-Communications-Escape Routes-Safety Zones) and the concept of “situational awareness.” Scientifically sound application of tools and models requires that the tools or models be used within their design limitations and in accordance with the tool assumptions.

Research can lead to development of additional or improved tools to help fire managers better identify those situations where extreme fire behavior may occur. The lack of a tool or model for a situation seen in the field does not mean extreme fire behavior cannot occur. Current training identifies circumstances that can result in extreme fire behavior, where increased awareness of multiple factors can guide fire managers to make decisions. Knowing what conditions can lead to extreme fire behavior, and knowing that you do not know whether those conditions exist, can be more important than any tools or models. Extreme fire behavior can occur on any fire.

Acknowledgements

The Extreme Fire Behavior synthesis (volumes 1 and 2) was funded by the Joint Fire Science Program (JFSP) Project Number 09-2-01-11 and a contribution from Project Number 09-S-03-1. In addition to the funds contributed by JFSP, a considerable amount of time and effort was provided by the authors and their respective agencies in the form of “in kind” funding. The following individuals reviewed the entire volume 2 manuscript and provided insightful comments: Jason Loomis (National Park Service, Fire Management Analyst, Northwest Geographic Area Coordination Center) and Ross Wilmore (U.S. Forest Service, East Zone Fire Management Officer, Upper Colorado River Interagency Fire Management Unit)

Each chapter was also peer reviewed, and we wish to acknowledge those individuals for their comments that significantly improved the document. Listed below are the chapter reviewers:

- Effects of Complex Terrain—Tom Rolinski (Fire Weather Program Manager, Southern California Geographic Area Coordination Center) and Kenn McCarty (California Department of Forestry and Fire Protection).
- Critical Fire Weather Patterns—Rick Ochoa (National Interagency Fire Center Predictive Services, retired), John Saltenberger (Fire Weather Services Program Manager, Northwest Geographic Area Coordination Center), and Nick Nimchuk (Fire Weather Section Head, Alberta Sustainable Resources, Alberta Canada).
- The Role of Fuels in Extreme Fire Behavior—Jason Loomis (National Park Service, Fire Management Analyst, Northwest Geographic Area Coordination Center)
- Fire Interactions and Mass Fires—Two anonymous reviewers.
- Column/Plume Dynamics and Spot Fires—Nicholas Gellie (Australian Fire Behavior Analyst) and Marty Alexander (Alberta School of Forest Science and Management, University of Alberta, Edmonton, Canada).
- Vortices and Wildland Fire—Don Haines and two anonymous reviewers.
- Crown Fire—Dave Thomas (U.S. Forest Service, retired), Phil Omi (Professor Emeritus, Colorado State University), Mike Jenkins and Wesley Page (Utah State University), Chad Hoffman (University of Idaho), John Kern (Florida Division of Forestry), David Weise (U.S. Forest Service), Nicole Vaillant (U.S. Forest Service), Bill Bereska (Alberta Sustainable Resource Development, retired), Terry Van Nest (Alberta Sustainable Resource Development, retired), Bill Droog (Ontario Ministry of Natural Resources), Steve Jakala (U.S. Fish and Wildlife Service), Brad Armitage (Ember Research Services Ltd.), Charley Martin (U.S. Geological Survey), Sonny Stiger (FireSafe Montana), and Mark Heathcott (formerly Parks Canada). The support of Mike Hilbruner (U.S. Forest Service, retired) is sincerely appreciated.

University, C. Hoffman (University of Idaho) and J. Kern (Florida Division of Forestry).

The authors also thank Victoria Werth for her help in writing the final document summary, and for editing and formatting the manuscript in preparation for publication.

Contents

1	Chapter 1: Introduction
	<i>Brian E. Potter and Paul A. Werth</i>
1	Definition
4	Methods
4	Literature Cited
5	Chapter 2: Effects of Complex Terrain on Extreme Fire Behavior
	<i>Craig B. Clements</i>
5	Introduction
5	Wind Systems in Mountainous Terrain
5	Dynamically Driven Winds
10	Thermally Driven Winds
17	Wind Modeling Tools: WindNinja
18	Summary
19	Future Needs
19	Literature Cited
25	Chapter 3: Critical Fire Weather Patterns
	<i>Paul A. Werth</i>
25	Introduction
25	Weather Elements That Promote Extreme Fire Behavior
27	Critical Fire Weather Patterns
29	Regional Critical Fire Weather Patterns
30	Northern Plains, Great Lakes, and the Northeastern United States
31	Southeastern United States
32	Southwestern United States
35	Rocky Mountain and Intermountain Regions
39	Pacific Northwest Region
41	California Region
43	Alaska Region
43	Canada
47	Australia
48	Models and Predictive Tools
49	The National Wildland Significant Fire Potential Outlook
49	GACC 7-Day Significant Fire Potential
49	Fuel and Fire Behavior Advisories
49	Other GACC Products and Services
49	Fire Weather Watches and Red Flag Warnings
49	Spot Weather Forecasts/Digital Web Services
50	Summary/Knowledge Gaps
50	Literature Cited

55	Chapter 4: The Role of Fuels in Extreme Fire Behavior
	<i>Russell Parsons, W. Matt Jolly, Chad Hoffman, and Roger Ottmar</i>
55	Introduction
55	Key Aspects of Fuels: the Fuels Pentagon
56	Scaling From Particles to Landscapes
56	Chemistry
59	Geometry
59	Quantity
60	Density
60	Continuity
61	Landscape-Scale Fuels and Extreme Fire Behavior
62	Landscape Fuel Distribution Patterns
63	Natural Fuel Changes
66	Anthropogenic (Human-Caused) Changes in Fuels
68	Climate Change and Other Agents of Fuel Change
70	Fuels Management Options That Reduce Extreme Fire Behavior Potential
70	Reduction of Surface Fuels
71	Increasing the Height to Live Crown
71	Decreasing Crown Density
71	Retaining Large, Fire-Resistant Trees
71	Negative Influences of Fuels Treatments
71	Temporal- and Spatial-Scale Considerations for Hazardous Fuels Management
72	Future Directions
73	New Developments in Fuels Mapping
73	New Developments in Fire Behavior Modeling
73	Concluding Remarks
75	Literature Cited
83	Chapter 5: Fire Interactions and Mass Fires
	<i>Mark A. Finney and Sara S. McAllister</i>
83	Introduction
84	Background: Time-Dependent Fire Behaviors
84	Fire Acceleration
85	Length of Fire Front
86	Flame Tilt
87	Spread Thresholds
87	Conditions Where Fire Interactions Occur
88	Specific Effects of Fire Interaction
88	Burning Rate
90	Flame Dimensions
92	Flame Temperatures and Pollutants
92	Indraft Velocity

95	Pulsation
96	Convection Column
97	Summary of Interaction Effects
97	Needs for Further Research and Application
98	Literature Cited
105	Chapter 6: Column/Plume Dynamics
	<i>Brian E. Potter</i>
105	Introduction
106	Plume-Dominated and Wind-Driven Fires
109	Adverse Wind Profiles and Low-Level Jets
110	Stability and Instability
111	Downbursts and Plume Collapse
115	Summary
115	Literature Cited
119	Chapter 7: Spot Fires
	<i>Brian E. Potter</i>
119	Introduction
119	The Spotting Process
121	Ember Generation
122	Ember Combustion and Fall Speed
125	Lofting and Transport of Embers
130	Ignition
130	Probability of Ignition
131	Ignition Delay Time
132	Spot Fire Prediction Tools
135	Knowledge Gaps
136	Literature Cited
141	Chapter 8: Vortices and Wildland Fire
	<i>Jason M. Forthofer and Scott L. Goodrick</i>
141	Introduction
141	Vorticity Basics
142	Fire Whirls
143	Fire Whirl Physics
149	Fire Whirls in the Real World: Common Features
151	Horizontal Vortices
152	Transverse Vortices
152	Longitudinal Vortices
155	Tree Crown Streets
155	Summary
157	Literature Cited

163	Chapter 9: Crown Fire Dynamics in Conifer Forests
	<i>M.E. Alexander and M.G. Cruz</i>
163	Introduction
169	Types of Crown Fires
172	Crown Fire Initiation
182	Crown Fire Propagation
183	Crown Fire Rate of Spread
191	Crown Fire Intensity and Flame Zone Characteristics
194	Crown Fire Area and Perimeter Growth
197	Crown Fire Spotting Activity
199	Models, Systems, and Other Decision Aids for Predicting Crown Fire Behavior
199	Rothermel Guide to Predicting Size and Behavior of Crown Fires
202	U.S. Fire Modeling System
205	Canadian Forest Fire Behavior Prediction System
210	Crown Fire Initiation and Spread (CFIS) System
211	Some Other Empirically Based Approaches
216	Physics-Based Models
218	Example of a Practical Application of Linking Empirical and Physically Based Models
218	Implications for Fire and Fuel Management
224	Future Outlook
226	Literature Cited
257	Acknowledgments
257	Common and Scientific Names
258	Unit Conversion Factors

Chapter 1: Introduction

Brian E. Potter¹ and Paul A. Werth²

The idea of “extreme fire behavior” is commonplace in the U.S. wildland fire community. It goes back, arguably, to the 1950s and the idea of a “blow-up” fire presented by George Byram. Byram (1954) listed the terms “blow up,” “conflagration,” and “erratic” as descriptors of “unusual high-intensity fires” (Box 1-1). He also used the phrase “extreme fire behavior” in both his 1954 paper and in his chapters in Davis (1959). Larger fires may be more likely to display these characteristics, he noted, but they can occur on a fire of any size. Since then, the concept and terms have become widely used.

In spite of this widespread use and implied understanding of what constitutes extreme fire behavior, there is no documented, critical examination of the types of fire behavior people consider “extreme.” Furthermore, whereas there is little question that the behavior labeled as extreme fire behavior by observers occurs, there are numerous explanations for that behavior that are now conventional wisdom, yet without any scientific support—the phenomenon is rarely in question, but the explanation may be. Actions based on incorrect explanations of extreme fire behavior can result in death or injury.

The primary goal of this synthesis is to summarize what is known scientifically about matters considered extreme fire behavior. The summary is presented to provide the most value possible to the operational fire management community. Research papers, although increasingly available to everyone, are not necessarily understandable by everyone. They contain substantial jargon and math and may only summarize their findings in terms of basic science. This synthesis distills the scientific information and provides references to the research papers. Note that science is a process of proposing possible explanations, and subsequently ruling out those explanations that contradict

evidence. It is easy to propose explanations, but proving them wrong can be easy or difficult. An explanation that is repeatedly tested, compared to observations, and never contradicted is not necessarily true, but the more it is tested, the more confidence scientists have that it may be.

In the case of extreme fire behavior, hard, reliable data are rare, making it very difficult to confidently refute a proposed explanation. Rather, it is much more common to be able to cite scientific reasons for greater or lesser confidence in the proposed explanation. In this synthesis and review, the authors hope to present what hard evidence there is, and, when there is none, to provide an understanding of the strong and weak points in a given explanation.

Definition

A working definition was necessary to begin and to execute the synthesis. Without it, the task of gathering and summarizing would be unbounded and impossible to complete. There is no single scientific paper that lays out a scientific definition of extreme fire behavior. The only official or specific definition of extreme fire behavior is established by the National Wildfire Coordination Group (NWCG) glossary of wildland fire terminology:

“Extreme” implies a level of fire behavior characteristics that ordinarily precludes methods of direct control action. One or more of the following is usually involved: high rate of spread, prolific crowning and/or spotting, presence of fire whirls, strong convection column. Predictability is difficult because such fires often exercise some degree of influence on their environment and behave erratically, sometimes dangerously.

Of the five properties “usually involved,” four are subjectively “high,” “prolific,” or “strong.” This makes the definition intractable for scientific purposes. Furthermore, the definition implies an inability to control in order to designate the fire behavior as “extreme.” This makes extreme fire behavior a function of control success or failure, not an objective, physical process.

¹ **Brian E. Potter** is a research meteorologist, U.S. Department of Agriculture, Forest Service, Pacific Wildland Fire Sciences Laboratory, 400 N 34th St., Suite 201, Seattle, WA 98103.

² **Paul A. Werth** is a fire weather meteorologist (retired), Northwest Interagency Coordination Center, 150 SW Harrison Street, Suite 400, Portland, OR 97201.

Box 1-1**Byram's (1954) Facts of Extreme Fire Behavior**

1. Most severe fires and a considerable number of blowups occur during the middle of the afternoon on sunny days. On such days, the atmosphere is often turbulent and unstable to a height of several thousand feet. However, some of the worst forest conflagrations in the United States have occurred either at night or reached to the peak of their intensity at night (usually between sundown and midnight). At this time, the lower layers of the atmosphere (up to 500 ft or more) are usually stable.
2. Some of the worst western fires in the past 15 years have been in rough country, which might indicate that topography is a dominating factor. On the other hand, there have been conflagrations, such as those that occurred in the Lake States many years ago, which burned in nearly flat or rolling country. Some of the conflagrations have been compared to "tornadoes of fires."
3. An intense fire may occasionally spread rapidly across slope or downslope at night in the general direction of the cool downslope winds. Yet this same rapid downslope spread may happen in the middle of the afternoon when the surface winds, if any, would be upslope. Fires have travelled across drainages (upslope and downslope) as though these did not exist.
4. Turbulence in the atmosphere seems to be closely related to extreme fire behavior; yet on a large proportion of warm, sunny days, the atmosphere is unstable. Often, fires do not build up to extreme intensity on such days.
5. Many intense fires have been accompanied by high winds; but some of the most dangerous and erratic fires have burned when the windspeed was not especially high.
6. High temperatures and low relative humidity accompany a large proportion of severe fires, but some of the most intense and rapid-spreading fires have burned when the temperature was low and falling. The fires in the East and Southeast in the fall of 1952 are examples.
7. Prolonged periods of drought and dry weather show a strong correlation with intense hot fires, but the Brasstown Fire in South Carolina in March 1953 burned only a week after nearly 2 in of rain had fallen on ground well charged with winter rainfall. However, both burning index and buildup index were high on this day.
8. The amount of fuel available to a fire is an important factor in its behavior. At times, the effect of an increase in quantity of fuel on fire intensity appears to be considerably greater than would be expected from the actual fuel increase itself. For example, doubling the amount of fuel might increase the apparent intensity four or five times.
9. Arrangement as well as quantity of fuel is important. Extreme fire behavior seems most likely to occur in dense conifer stands. Intense fires also build up in stands of evergreen brush, and in the South can readily cross swamps if the brush is dense enough.
10. On those fires to which one would be most likely to apply the term "blowup" (owing to the sudden and often unexpected buildup of turbulent energy), there is an obvious and well-developed convection column that may extend high into the atmosphere.
11. Large fires exhibiting extreme behavior have been known to put up convection columns to a height of 25,000 ft or more. Since about 70 percent of the total air mass is below the tops of such convection columns, these fires have literally pierced the atmosphere. They are volume phenomena and have storm characteristics like certain other disturbances in the atmosphere. This in part seems to explain why they do not conform to the "rules" of fire behavior. These "rules" are based on the far more-frequent ordinary fire, which is pretty much a surface phenomenon.

At the initiation of this project, the lead authors asked the fire behavior community for input on possible definitions of extreme fire behavior and examples of phenomena they considered extreme fire behavior, whether those examples matched the NWCG definition or not. Several people responded—mostly with examples—either via email or through MyFireCommunity.net, and the authors used that feedback in their initial discussion of the working definition. The phenomena listed in these responses included:

- Mass ignition.
- Actual plume dominance.
- Rapid exponential growth of spot fires.
- Spotting distances in miles.
- Things that just made me go, “Huh ... didn’t expect that.”
- Fire activity that has that momentum feedback character, like Jimi Hendrix putting the guitar up to the amp, and it just builds and builds feeding back on itself.
- When the fire and convection column induce high levels of turbulence into the wind field; when the momentum flow into the convection column is of the same order of magnitude as the momentum in the wind field.
- Very rapid fire spread.
- Three-dimensional fire.
- Fire behavior in which large changes take place rapidly.
- Flame attachment (the laying over and direct contact of flame with new fuels when there are steep slopes and string winds).

The responses made it quite clear that operational users had thought about extreme fire behavior well beyond any formal definition. They also recognized the difficulty of creating a precise definition that could be applied predictively, or a definition more concrete than “I know it when I see it.”

After reviewing and discussing practitioner responses, the authors felt that there were too many individual phenomena considered extreme fire behavior for a definition to include any sort of list. Furthermore, most tractable

definitions included some level of subjectivity. In the end, the agreed definition for this project was:

Fire spread other than steady surface spread, especially when it involves rapid increases.

This definition includes most or all of the phenomena listed above, although admittedly indirectly in some cases. It includes some subjectivity, as “rapid” can be a matter of opinion. However, this is not the core of the definition—it is included to emphasize the safety and operational importance of increasing spread as opposed to decreasing or unusually slow spread. Furthermore, whereas the NWCG definition heavily leans toward atmospheric conditions and may underrepresent the importance of fuels and topography, this definition does not emphasize any one element of the behavior triangle (fig. 1-1).

This definition has other shortcomings important to bear in mind. The authors of the fuels chapter added for volume 2 (this volume) expressed two main concerns over the working definition. To a degree, these concerns were part of the original discussion. They are worth noting here to further emphasize the challenges of defining extreme fire behavior.

First, the working definition lacks a basis for evaluating the degree of extremity, which would be useful from an analytical perspective and would tend to lead towards more

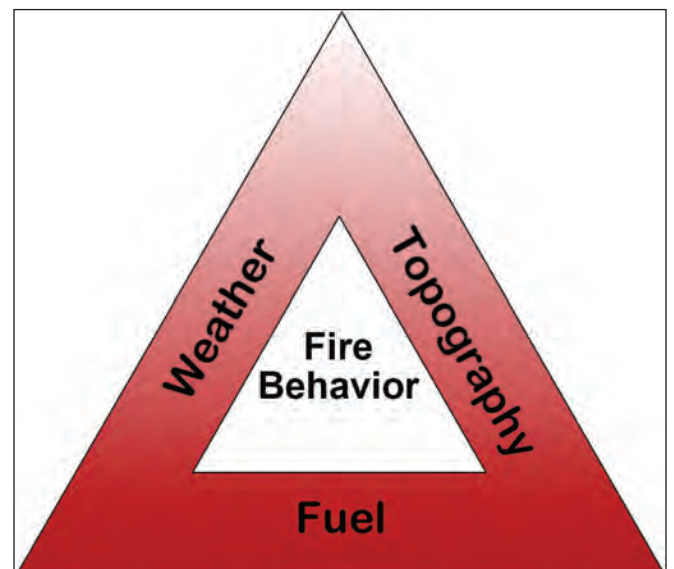

Figure 1-1—The fire behavior triangle.

specific scientific investigations regarding the nature of extreme fire behavior. For example, earthquake magnitude is characterized with the Richter scale, a base-10 logarithmic scale obtained by calculating the logarithm of the amplitude of waves measured by a seismograph (Richter 1935). This metric provides useful insights regarding the nature of the phenomenon and associated aspects across a wide range of scales (Bak et al. 2002, Rundle 1989). No such metric has yet been developed for wildland fire, but such a measure would be of great utility in characterizing and better understanding extreme fire behavior.

Second, this definition ignores the context within which extreme fire behavior occurs. Despite its simplicity, the fire behavior triangle reminds us that several factors, including fuels, weather, and topography, interact to influence how a fire burns. For a given set of fuel conditions, fire behavior can range from none (where the fire fails to ignite) to a very active, high-energy fire. The other sides of the triangle constitute constraints on the magnitude of the role of fuels in influencing fire behavior. In many ecosystems, such as subalpine forests, fires may occur rarely, but, when they do, it is under extreme weather conditions, often on steep slopes, and consequently they burn intensely. In such cases, fire behavior is much more influenced by weather and topography than by the fuel, and can be relatively insensitive to fuel conditions (Bessie and Johnson 1995). If all fires that burn in a given ecosystem are, by definition, extreme, the concept is not of particular use in that ecosystem. Different ecosystems have very different fire regimes; fire behavior that is extreme in one ecosystem may be commonplace in another.

All fire behavior must be considered within the context of fuels, weather, and topography, and none of these factors can be omitted when framing perceptions of extreme fire behavior. An ideal definition of extreme fire behavior would account for this and enable us to focus better on the particular aspects of each component of the fire behavior triangle and their contribution to extreme fire behavior.

Methods

The authors divided the work of synthesis and review based on expertise. The division was necessary to the synthesis, but it is also artificial, and the various sections overlap

substantially. Many areas of overlap are explicitly noted, and readers will undoubtedly see other areas.

The review incorporated three primary sources of information. First and foremost was the peer-reviewed scientific literature. This is the most authoritative source of information to support or refute any explanation of what causes extreme fire behavior. Second was feedback from and interaction with practitioners. The project web site allowed reader comments and discussion, and, when appropriate, these guided the review. The third source was documents that are not peer reviewed—often referred to as “grey literature.” Peer review was the exception to the rule for many years in the field of forest fire research, so there is an extensive body of literature that was not peer reviewed. The problem with grey literature is that it has not been tested or widely available, so the scientific rigor of its content is unknown. It can, however, provide insight and information, and the authors did not want to ignore it.

Literature Cited

Bak, P.; Christensen, K.; Danon, L.; Scanlon, T. 2002.

Unified scaling law for earthquakes. *Physical Review Letters*. 88: 178051.

Bessie, W.C.; Johnson, E.A. 1995. The relative importance

of fuels and weather on fire behavior in subalpine forest. *Ecology*. 76: 747–762.

Byram, G.M. 1954. Atmospheric conditions related to blowup

fires. Sta. Pap. 35. Asheville, NC: U.S. Department of Agriculture, Forest Service, Southeastern Forest Experiment Station. 34 p.

Davis, K.P. 1959. Forest fire: control and use. New York:

McGraw-Hill. 584 p.

Richter, C.F. 1935. An instrumental earthquake magnitude

scale. *Bulletin of the Seismologists Society of America*. 25-1.

Rundle, J.B. 1989. Derivation of the complete Gutenberg-

Richter magnitude-frequency relation using the principle of scale invariance. *Journal Geophysical Research*. 94: 12337–012312, 12342

National Wildfire Coordinating Group. Glossary of wildland

fire terminology. <http://www.nwccg.gov/pms/pubs/glossary/index.htm>. (June 1, 2011).

Chapter 2: Effects of Complex Terrain on Extreme Fire Behavior

Craig B. Clements¹

Introduction

Atmospheric processes in regions of complex terrain have received considerable interest in the research community for decades. Traditionally, the term “complex terrain” has been used to differentiate mountainous terrain from relatively flat and simple terrain. Research in mountain meteorology has its foundation in the Alps, and our present understanding of mountain circulations and the mountain atmosphere in general came from the early observational studies of Wagner (1938), Ekhardt (1944), and Defant (1949).

The mountain meteorology research community most likely adopted the term “complex terrain” from the Atmospheric Studies in Complex Terrain (the ASCOT program), which focused on observational campaigns of thermally driven circulations in valleys and, in particular, Colorado’s Brush Creek Valley (Whiteman 1990).

A new classification of mountainous terrain by Meybeck et al. (2001) provided 15 relief patterns based on relief roughness and elevation. Relief roughness is defined as the difference between maximum and minimum elevation divided by half the length of cell used in the elevation data set (e.g., digital elevation model [DEM]). This terrain parameter is similar to the average slope typical of terrain classifications. Although Meybeck et al. determined many terrain types, they did not define any as complex terrain. Meybeck et al. classified mountains as terrain with elevations higher than 500 m and relief roughness greater than 20 percent. One problem with this classification is that high plateaus are not mountains. Major river valleys can be incised into a high plateau such as the Grand Canyon. Although this is not “mountainous terrain,” it is complex.

Most applicable to meteorological use of the term “complex terrain” is when defining the effect that land shape or topography has on meteorological measurements (Brode et al. 1987). These terrain effects include aerodynamic wakes, density-driven slope flows, channeling effects

of upper level winds, and flow accelerations over the crest of mountain ridges. These flows affect wind speed and wind direction measurements made in mountainous regions.

For fire behavior applications, the term “complex terrain” is used to describe regions of relative relief and, in most cases, mountain topography.

Wind Systems in Mountainous Terrain

Wind systems in mountainous terrain can be classified into two main types based on their forcing mechanisms: dynamically driven and thermally driven winds. Although thermally driven circulations occur more regularly in mountain terrain and are commonly experienced by hikers and climbers during fair weather conditions, it is the dynamically driven winds that can play a larger role in producing extreme fire behavior owing to their generally stronger surface wind velocities. However, thermally driven circulations are subject to diurnal transition periods where atmospheric stability changes twice daily, potentially leading to extreme changes in observed fire behavior. This chapter will review the main mesoscale and local-scale wind systems observed in mountainous terrain that can potentially lead to extreme fire behavior.

Dynamically Driven Winds

Dynamically driven winds are generally considered the strongest of the wind systems in mountainous terrain and include downslope windstorms such as foehn and Santa Ana winds, strong surface winds associated with mountain wave development, gap winds, and channeling of synoptic-scale winds. The factors that affect these terrain-forced winds as summarized by Whiteman (2000) are (1) the stability of the air approaching the mountains, (2) the speed of the airflow, and (3) the characteristics of the underlying topography or mountain barrier.

Foehn winds—

One of the most important dynamically driven winds affecting fire behavior in mountainous terrain is the Chinook or foehn wind. Foehn winds (pronounced “firn”)

¹ Craig B. Clements is an assistant professor of meteorology, San Jose State University, San Jose, CA 95192.

are downslope wind events and are often associated with extreme fire behavior because of their near-surface high windspeeds, warm temperatures, and low relative humidities (Durrán 1990, Whiteman 2000). As a foehn develops, its onset can cause rapid changes in temperature and humidity because of adiabatic compression as air descends the lee side of mountain ranges. Extreme fire behavior can potentially occur during nighttime at the onset of a foehn event; strong winds will prevent nocturnal inversions from forming allowing nighttime temperatures to remain warmer (Whiteman 2000). Foehn winds can also start and stop suddenly, called a foehn pause (Whiteman 2000). The alternating wind break-in and cessation during a foehn event can cause air temperatures to oscillate sharply and can thus affect fire behavior. The foehn pause has been associated with changes in upstream conditions, including stability and cross-barrier windspeed that cause the wavelength of the waves to change (Whiteman 2000), and to lifting of the foehn wind by other local-scale drainage flows (Baumann-Stanzer and Piringer 2004).

Foehn winds are common in most mountainous regions around the world. In the lee of the Rocky Mountains of North America, they are called chinooks. The chinook is most prevalent in winter months when strong westerly winds cross the Rockies (Whiteman 2000); however, when the synoptic conditions are right, chinooks do occur during fire season (see the next chapter, “Critical Fire Weather Patterns”).

In northern California, foehn winds that flow from the Great Basin over the Sierra Nevada to the Central Valley are known as north winds and in the region of Yosemite are called Mono winds (Ruscha 1976). Even more localized in the San Francisco Bay Area, these winds are known as diablo winds. Foehn winds in the Cascade Mountains of the Pacific Northwest are called east winds as they blow from east of the Cascades and descend becoming warmer and drier over the west slope of the mountain range. In Utah, the local foehn is known as the Wasatch wind as it descends from the higher elevations east of the Wasatch Mountains to the Salt Lake Valley. A comprehensive review of foehn winds of the Western United States is found in Whiteman (2000).

Santa Ana winds—

The most notable foehn wind associated with extreme fire events is the Santa Ana of southern California. High windspeeds and extreme dryness associated with these episodes have been characterized as causing extreme fire behavior during fall in southern California. Barry (2008) stated that the Santa Ana develops as a result of high pressure over the Great Basin and development of a surface low off the southern California coast. An upper level trough to the east and a ridge in the eastern North Pacific causes the development of northerly flow.

Hughes and Hall (2009) suggested that the surface winds associated with Santa Ana events are produced by two mechanisms. When strong mid-tropospheric winds impinge on mountaintops in a stably stratified environment, gravity waves transfer midlevel momentum to the surface, causing strong lee-side surface winds. However, Hughes and Hall (2009) found strong variability in Santa Ana events with many days exhibiting strong offshore flow and weak synoptic forcing. They suggested local thermodynamic forcing must also cause offshore surface flow. When cold air is trapped in the Great Basin by topography, a hydrostatic desert-ocean pressure gradient forms, causing a negatively buoyant gravity current to flow through mountain gaps at the surface.

Numerical modeling results by Huang et al. (2009) showed that a coupling between the synoptic scale and mesoscale exists leading to the development of Santa Ana winds. The coupling effects of the synoptic scale with the mesoscale are classified in three stages. During stage I, mesoscale subsidence occurs in the exit region of the jet stream causing an initial surge of dry air to the surface as a result of moisture divergence behind a surface cold front that was located in the Southwestern United States. During stage II, anticyclonic curvature of the jet stream increases, and strong northeasterly winds in the jet exit region advect dry air toward the California coast. During stage III, the extremely dry mid-tropospheric air is transported to the boundary layer by wave breaking and strong turbulence, which leads to the formation of a hydraulic jump on the east side of the Coast Range, creating the Santa Ana winds.

Many studies have focused on the large-scale dynamics of Santa Ana events, but few have investigated extreme fire behavior associated with these events. One recent study was made by Maranghides and Mell (2009) who conducted a postincident analysis of the fire behavior that occurred during the Witch and Guejito Fires near San Diego, California, in 2007. Surface winds in the region were about 11 m/s with gusts of 15 m/s. A home weather station in the region reported a maximum windspeed of 25 m/s. Relative humidity dropped from 90 to 8 percent during the onset of the Santa Ana wind event. Spread rates during the Guejito Fire were estimated between 1.7 and 2.5 m/s. Spotting distances were estimated to be approximately 4.5 km from the Guejito Fire front. The surface wind measurements were limited to just a few sites in the region of these fires, but indicate very strong surface winds and rapid fire spread. Better measurements of fire-atmosphere interactions during Santa Ana events would lead to improved understanding of extreme fire behavior during such events.

Esperanza Fire—The Esperanza Fire occurred on 26 October 2006 near Cabazon, California, and was an event where extreme fire behavior was associated with five firefighter fatalities. The extreme fire behavior was caused by the fire spread up a narrow canyon enhanced by flow channeling created by the onset of a Santa Ana wind (Coen and Riggan 2010, Esperanza Investigation Team 2006). One key finding (finding 29, Esperanza Investigation Team 2006) was that none of the fire shelters for the five firefighters who were killed by the burnover were deployed, indicating that the head fire must have accelerated as it came up the creek drainage and caught all firefighters by surprise, leaving them no time to deploy their shelters.

One of the major contributing factors was the Santa Ana winds coming into alignment with the “unnamed creek drainage” as a channeled flow, which increased the surface winds in the canyon. Additionally, the inversion was penetrated by the convection column produced by the up-canyon fire run resulting in extreme fire behavior and area ignition. Coen and Riggan (2010) confirmed the presence of

strong winds that aligned with the canyon; however, these surface winds were a result of atmospheric gravity waves bringing high-momentum east-northeasterly winds to the surface.

Sundowner winds—

Another foehn wind that has played a major role in observed extreme fire behavior is the sundowner wind of Santa Barbara, California. The sundowner is a localized downslope wind that flows from the Santa Ynez Mountains down to the narrow coastal plain of Santa Barbara. The topography is unique, as it is a section of coastline and mountains that are aligned west to east. The winds are a result of perpendicular flow at ridgetop, typically associated with warmer and drier air near the mountaintops and cooler, higher humidity air at the coast. The extreme effects of the winds include the onset of severe wind velocities and abrupt warming. The abrupt observed warming is a result of the adiabatic descent of mid-tropospheric air to the surface and the replacement of cooler marine air at the coast with the foehn wind (Blier 1998). The sundowner name is due to the time of onset, typically during the later afternoon or evening hours (Ryan 1994). One synoptic regime associated with sundowner events includes the alignment of an inverted ridge off the California coast and inverted trough in the interior of the Great Basin allowing for northerly winds along the California coast (Blier 1998). Additionally, as with other foehn events, the presence of a stable layer at ridge height enhances the flow and formation of mountain waves (Blier 1998). Sundowners have been associated with extreme fire behavior. For example, during the Painted Rock Fire in June 1990, an extreme sundowner event caused devastating winds and fire spread rates. Additionally, downslope winds can cause severe downslope fire spread as noted by Weise and Biging (1996).

Washoe zephyr—

The eastern Sierra Nevada is associated with strong chinook wind events in the winter and spring (Zhong et al. 2008a). During the summer and fall, however, the Washoe zephyr occurs regularly. The Washoe zephyr is a daytime,

down-canyon wind that occurs on the lee side of the Sierra Nevada (Clements 1999, Zhong et al. 2008a) often initiating afternoon thunderstorms in western Nevada (Hill 1980). Zhong et al. (2008a) defined the Washoe zephyr as a westerly wind with a sustained windspeed greater than 7 m/s starting after noon Local Standard Time (LST). Climatology of the zephyr indicates that 85 percent of the time these events start between 1300 and 2000 LST with 70 percent onset between 1500 and 1800 LST. Half of the events have a duration of 3 to 6 h, and few events last more than 9 h (5 percent). Although zephyr events do occur all year, they are most frequent during the summer months. A frequency of less than 10 percent was observed from November to February.

The characteristics of the Washoe zephyr are somewhat opposite of what is generally observed in mountainous terrain where up-valley winds dominate in the afternoon. The zephyr develops in late afternoon during the summer and fall, and blows strongly down canyon with velocities regularly exceeding 5 m/s. The vertical wind profile of the zephyr is characterized by a strong low-level jet that produces strong vertical wind shear (defined as the change in windspeed or wind direction with height) and turbulence (Clements 1999, Kingsmill 2000) at the surface. The strong and gusty nature of the zephyr lasts throughout the night and finally diminishes, allowing thermally driven down-valley winds to persist until morning (Clements 1999).

The dynamics of the Washoe zephyr have often been questioned. Zhong et al. (2008a) showed through mesoscale numerical modeling and climatological analyses that the Washoe zephyr is driven by the cross-barrier pressure gradient formed in response to the thermal low of the Great Basin.

One incident in the lee of the Sierra Nevada that could be attributed to a Washoe zephyr-like event occurred during the Seven Oak Fire of the Inyo Complex (California Department of Forestry and Fire Protection 2008). On the afternoon of 7 July 2007 at 1400 Pacific Daylight Time (PDT), a strike team was assigned to burn out an area in order to protect the historical Mount Whitney Fish Hatchery on the western side of Owens Valley near the town of Independence, California. The site was just below the eastern

escarpment of the Sierra crest. At 1430 PDT, the wind had changed and caused the fire to cross the planned control line. It is reported that at 1445 PDT, the fire intensified and the winds increased and began changing directions. At this time, the firefighters realized they were losing control and retreated toward their designated safety zone. They deployed their shelters while waiting out the burnover in a small pond. The entrapment resulted in burn and respiratory injuries to all nine firefighters and the total loss of one engine and damage to another. The incident report indicated that skies were clear with no cumulus buildup. The day before, when the fire started, there were frequent lightning strikes in the higher elevations of the Sierra with strong, gusty and erratic winds. A 26 m/s wind gust was recorded by fire personnel using a Kestrel handheld anemometer. Daytime temperatures on July 7th ranged from 32 to 38 °C at 1247 PDT. Relative humidity (RH) values ranged from a high of 13 percent to a low of 4 percent at 1447 PDT. At the Oak Creek remote automated weather station (RAWS), a wind gust of 22 m/s also occurred at 1447 PDT. Winds in the afternoon were sustained 4.5 to 6.7 m/s gusting to 13 m/s. At the time of the burnover, winds were 9 to 13 m/s out of the southwest.

Although the southeastern Sierra is not usually associated with Washoe zephyr events because of the higher terrain and fewer gaps in the crest, the observed characteristics have some similarities to the zephyr. Southwesterly winds with recorded velocities of 4.5 to 6.7 m/s are similar to what has been observed in Lee Vining and Reno to the north. The onset of the stronger winds occurring between 1400 and 1500 PDT is typical for zephyr events. However, the Washoe zephyr typically has a more westerly component, but this could possibly be effects of flow channeling along the foothills of the Sierra eastern escarpment as found by Zhong et al. (2008b).

Terrain channeling effects—

Forced channeling or pressure-driven channeling of upper level, larger scale winds can cause drastic changes in windspeed and direction to occur in valleys (Whiteman 2000). These high wind events can be produced by (1)

downward momentum transport, (2) terrain channeling, and (3) pressure-driven channeling (Whiteman 2000, Zhong et al. 2008b). For a more detailed review on terrain channeling effects in mountainous regions, please refer to Sharples (2009).

The downward transport of momentum occurs when winds within a valley are strongly coupled to winds aloft (Zhong et al. 2008b). For this condition to occur, there must be vertical mixing associated with unstable or neutral stability allowing upper level winds to penetrate to the surface. When winds in a valley are driven by this mechanism, they are expected to align with the wind direction aloft. Downward transport of momentum in valleys occurs often.

Another channeling effect is “forced channeling,” which occurs when strong winds aloft blow directly along the valley’s axis (Whiteman 2000). According to Whiteman, forced channeling is more likely to occur during the daytime when the valley atmosphere is usually neutral or unstable. It typically begins in later morning after the breakup of the nocturnal inversion, resulting in abrupt changes in windspeed and gustiness. Forced channeling is strongest when the pressure gradient aloft is weak in the along-valley direction. Upper level winds can also be channeled when they blow at oblique angles to the valley axis, either flowing up or down the valley.

Thirtymile Fire—The Thirtymile Fire investigative report indicates that fire-induced winds were associated with the deaths of four firefighters who deployed at a site located 30 m upslope from the valley floor. The analysis suggests that the deployment site happened to be located at a point where the convection column had impinged on the valley sidewall, causing extensive convective heat to pass over the deployment site leading to the asphyxiation of the entrapped firefighters. Although early afternoon winds in the canyon were relatively light, strong fire-induced winds were reported to be on the order of 22 m/s at the time of deployment (Brown 2002).

Tree needle heatset observations made at the deployment sites (Brown 2002) indicated that the fire-induced winds were in the up-canyon and upslope direction, suggesting that the convection column was being channeled

up the canyon rather than rising vertically from the surface. The fact that the convection column near the surface was being advected up canyon suggests that the surface winds were blowing through the fire-front boundary. Additionally, observed spread rates at this time increased and caught the firefighters off guard (Brown 2002). The increase in fire spread rate was a result of the fire running in the crowns, driven by the up-canyon winds. At the same time, upper level winds were from the southwest and in alignment with the canyon’s axis, providing a source for increased wind velocities. The upper level winds may have been mixed downward from aloft to the surface owing to the dynamics of the convection plume. The downward mixing of horizontal momentum could help explain why the fire front accelerated and caused the burnover to happen so quickly. These events can be surge-like and last for only a few minutes. Another mechanism that could have been responsible for the convection column impinging on the canyon sidewall might be strong downdrafts that exist in plumes or convection columns. These downdrafts can be responsible for the strong fire-induced winds that are often observed at the fire front and may drive fire spread (Clark et al. 1996, Clements et al. 2007).

Another mechanism possibly responsible for the intense fire-induced winds could be a developing low pressure field. This may have existed in the upper elevations of the canyon ahead of the fire front. This type of pressure perturbation ahead of the fire front has been found in numerical simulations done over flat terrain (Clark et al. 1996) and observed over slopes with crosswinds (Clements and Heilman 2010). A region of low pressure develops as a result of a hydrostatic pressure gradient that forms at the base of the convection column (Clark et al. 1996). Within a canyon during daytime, low pressure exists owing to the solar heating of the canyon volume causing up-canyon winds to occur. With the additional heating caused by the advection of the plume up the canyon, acceleration in the wind field could result and be the cause of the extreme fire-induced winds that blew through the fire front advecting hot gases along the sidewalls of the canyon. Although these mechanisms could be responsible for the plume impingement on the canyon sidewall, none has been confirmed.

Pressure-driven channeling—

Pressure-driven channeling occurs when there exists a larger scale pressure gradient above the valley that is superimposed on the valley below. The direction of the winds in the valley depends on the along-valley component of the horizontal pressure gradient. Pressure-driven channeling causes winds to always blow along the valley axis from the high pressure end of the valley to the low pressure end of the valley (Whiteman 2000, Zhong et al. 2008b). Pressure-driven channeling is strongest when the pressure gradient is strongest in the along-valley direction.

Thermally Driven Winds

Thermally driven wind systems are very common because they are diurnally driven (daytime vs. nighttime) and are probably more experienced by wildland firefighters and backcountry hikers. These winds include the classic valley and slope winds. There is a distinct diurnal structure to the evolution of the thermally driven flows where their direction typically reverses daily owing to changes in the pressure gradient and buoyancy.

Two main circulations exist in the valley atmosphere: valley winds and slope winds. Valley winds consist of two diurnal regimes: up-valley wind during the daytime and down-valley wind at night. Slope winds consist of a similar diurnal structure with downslope winds occurring during nighttime periods and upslope winds during daytime (Ekhardt 1944; Vergeiner and Dreiseitl 1987; Whiteman 1990, 2000). The strength of thermally driven circulations is a function of aspect, time of day, and time of year (Whiteman 2000). Of the two wind systems, valley winds play a larger role in fire behavior because of their overall stronger velocities and horizontal extent.

Slope winds—

Slope winds are the most intermittent of the thermally driven flows found in mountain environments (Vergeiner and Dreiseitl 1987, Whiteman 1990). This is due to both slope length and depth. Although there have been numerous studies focused on downslope flows (Horst and Doran 1986, Mahrt 1982, Manins and Sawford 1979, Papadopoulos and Helmise 1999, Whiteman and Zhong 2008), limited work

has been focused on upslope winds. Vergeiner and Dreiseitl suggested that this is due to their intermittency and overall difficulty in obtaining useful measurements. They also concluded that any field study focused on measuring upslope flows will “give random inconclusive results from which representative values of mass and heat transport in the slope layer cannot be derived” (Vergeiner and Dreiseitl 1987).

Fire behavior studies on slopes and especially field studies are limited, and therefore it is difficult to determine whether or not diurnal slope flows help drive the fire along the slope rather than being dominantly driven by the fuels and the effect of radiative and convective transfer from the fire front to the fuels (flame attachment). However, as will be discussed in a later section, the interaction of slope winds and valley winds can create shear layers, producing turbulence along the slopes that can potentially lead to extreme fire behavior scenarios.

Upslope winds—

According to Whiteman (2000), upslope flows have depths of 10 to 50 m above ground level (AGL) and velocities on the order of 1 to 5 m/s. Upslope flows react instantly to changes in insolation and begin immediately after sunrise (Vergeiner and Dreiseitl 1987). Two main forcing mechanisms drive the flow upslope: the pressure gradient force and the buoyancy force (Atkinson 1981). The air over a slope is heated by the sunlit ground causing an air parcel adjacent to the slope to have a higher potential temperature and lower density than air at the same altitude, but away from the slope. It is this temperature perturbation that drives the pressure gradient to force air toward the slope from the center of the valley (at the same altitude). Buoyancy drives the air parcel vertically above the slope, and the sum of both buoyancy and the horizontal pressure gradient causes the air parcel to accelerate up the slope while being replaced by air from over the valley center. This is the classic upslope circulation during ideal, fair weather conditions and is responsible for transporting heat and mass to the valley atmosphere (Vergeiner and Dreiseitl 1987).

One of the more recent observations of upslope flows was made by Reuten et al. (2005), who observed upslope

flows at the foot of a mountain range with a slope angle of 19° and a ridge height of 780 m above sea level (ASL) in coastal British Columbia. Their observations indicate that the daytime upslope flows were strong with velocities up to 6 m/s and occurred over a depth of nearly 500 m AGL. Equally strong and deep return circulations occurred within the convective boundary layer (CBL). The transport of mass of the upslope flow and return flow approximately balanced during the morning period suggesting a closed-cell slope flow circulation within the boundary layer. This is the first observational evidence of the closed slope flow circulation.

The intermittency of daytime upslope flows may influence the upslope fire behavior by possibly increasing upslope rate of spread (ROS) at random intervals. However, this influence is more likely limited owing to the weak nature of upslope velocities. Valley winds may have a larger impact on fire behavior on slopes owing to the cross-slope wind component of valley winds. As a valley wind develops, it can overcome the slope wind layer along the slope and create a cross-slope flow (Whiteman 2000). Fire spread will be upslope, but depending on the strength of the valley wind can likely be reduced and spread laterally along the slope. Synoptically forced winds that penetrate the valley atmosphere would intensify this effect.

Fire behavior on sloped terrain—

Slope-driven fire spread has been studied for decades because many wildfires occur in regions of mountainous terrain, and fire spread on slopes is associated with increased acceleration leading to extreme fire behavior (Cheney and Sullivan 2008). Often the effect of slope on fire behavior can be visualized by the smoke column where smoke is entrained up and along the slope rather than producing a vertical column above the flame front (fig. 2-1). This observation suggests that the effect of terrain is more pronounced than that of wind. Understanding of fire behavior on slopes is derived mostly from laboratory-scale experiments conducted in wind tunnels (e.g., Weise and Biging 1996, Viegas 2005); however, recently a number of numerical simulations have been conducted (Linn et al. 2010). The effect of slope has been viewed as an added component of wind velocity since



Figure 2-1—Fire behavior on a steep slope in a narrow canyon during a prescribed fire in chaparral fuels at Henry Coe State Park, California, November 2008. Ignition was made by a heli-torch in a cross-slope pattern starting from the top and continuing with three to four passes until igniting the bottom of the canyon. Heat transport is up and along the slope as indicated by the smoke entrainment occurring from the bottom of the canyon up the slope into the base of the convection column at the ridge top. Background ambient winds were weak as determined by the vertical smoke column, and fire spread was caused by flame attachment with the fuels.

1946 (Weise and Biging 1997). There have been attempts to determine both the separate and combined effects of wind velocity and slope angle on spread rate and flame length (Weise and Biging 1997). Results from Weise and Biging indicate that as slope and wind velocity increase, fire behavior, including flame length and spread rate, increases significantly as compared to no-wind and downslope conditions. Backing fires on slopes can result in weak to no spread. Weise and Biging suggested that the wind acts to cool the unburnt fuel in advance of the fire front.

Santoni et al. (1999) formulated a model to account for upslope fire spread and compared the solution to experimental results obtained using a tilted, combustion table. They suggested that the flame's heat that is radiated ahead of the fire front toward the fuel is more important under slope conditions. They found that the ROS increases with slope. They also found that the fire front shape distorts toward the slope as the fire spreads upslope becoming more pointed. The fire front distortion increases with increasing slope angle.

Chimney effects—

An important aspect of upslope wind on fire behavior would be the effect that chimneys or steep gullies have on driving wind up the mountainside. Chimneys and steep gullies can help channel upslope flow if they are not lined with dense vegetation. Within the canopy, air is usually cooler than the free atmosphere and can result in drainage winds flowing below the canopy top while upslope winds occur above the canopy (Belcher et al. 2008, Whiteman 2000). However, few if any wind velocity observations in chimneys or steep gullies have been documented.

Explosive fire behavior—

Eruptive fire behavior has been reviewed by Viegas and Simeoni (2010) where they define extreme fire acceleration as fire blowup characterized by a sudden change of spread rate and energy-release rate. This designation was first proposed by Viegas (2005, 2006), and such fire eruptions, especially those associated with canyons, are not rare (Viegas and Simeoni 2010). Laboratory studies using a combustion chamber and a fuel bed configured on a tilting, V-shaped table to replicate a steep chimney were conducted by Viegas and Pita (2004) and Viegas (2005). Their conclusions suggest that forest fire blowup depends mainly on fuel-bed properties and on the initial fire spread conditions dictated by topography or wind. Viegas (2005) also found that if the slope is not sufficiently long, blowup may not occur; however, a fire in the same fuel bed on a very steep slope will start with a high ROS, and blowup may occur quickly. Although laboratory studies in general do provide some insight, they are limited by the experimental design, as are most chamber-table studies owing to the limited table length, and the

fact that atmospheric stability in these experiments is inherently limited to neutral conditions. However, one advantage of laboratory-scale experiments is that they remove many uncertainties that are found at the landscape scale such as wind and turbulence. Dold and Zinoviev (2009) and Dold (2010) suggested that when a fire is spreading upslope, heated air ahead of the fire front causes plume attachment with upslope fuels, leading to accelerated fire spread. This may potentially result in dangerous fireline conditions. They suggested that airflow is generated by the fire and is independent of the ambient wind.

Wu et al. (2000) conducted a series of laboratory experiments and successfully visualized experimental fire plumes interacting with an inclined surface by using a grid schlieren system. They found that plumes were characterized by two parameters, plume attachment length and plume angle, and these were used to determine a critical inclination angle for flame attachment to occur. Their results suggested that 24° is a critical angle for attachment to occur. Additionally, Wu et al. found that the critical inclination angle is not sensitive to the heat release rate or surface conditions.

Dupuy and Maréchal (2011) conducted a series of laboratory fire experiments to determine the contribution of radiation and convection to fuel bed preheating on slopes of 0°, 10°, 20°, and 30°. Their results indicate that radiative heating is the dominant heat transfer mechanism on slopes between 0° and 20° that are close to the fireline. Convective heating was also found to be significant, becoming one-third of the total heat flux on the 20° slope. When the slope angle increased from 20° to 30°, the ROS increased by a factor of 2.5 owing to an increase in convective heating; at this angle, radiative heating stopped increasing. Their results also showed that far from the fireline, cooling by convection was found to be substantial except on 30° slopes.

Sharples et al. (2010a) suggested that the trench effect or flame attachment phenomena observed in structure fires of stairwells can be used as a surrogate for wildland fires exhibiting explosive behavior. The trench effect produces rapid fire spread in enclosed slopes such as escalator or stairwells by the interaction of the buoyant plume and an inclined trench of the stairwell. Plume impingement on

an inclined surface enhances preheating and pyrolysis of the fuel resulting in accelerated fire spread. Sharples et al. (2010a) suggested that the trench effect is a misnomer and the effect is really due to the trenchlike configuration of the fuels that limited lateral entrainment into the plume. They suggested that plume attachment or flame attachment are more appropriate to describe the phenomenon. This conceptual model applies to steep gullies or canyons, as these terrain features can potentially limit the lateral entrainment into the plume and result in eruptive or accelerated fire spread up the canyon.

Sharples et al. (2010a) also noted that confined slopes over 25° are the most prone to flame attachment and the reason observed eruptive wildfire behavior is more prevalent on steep slopes and in steep canyons. This observation is in agreement with the results from Wu et al. (2000), who suggested 24° as a critical slope angle for flame attachment to occur.

Modeling of fire behavior on slopes—

To date, most studies aimed at determining the role of slope on fire behavior have based their models on wind tunnel experiments. More recently there have been attempts at using physics-based, coupled fire-atmosphere modeling systems to evaluate the role of slope on fire behavior (Linn et al. 2007, 2010). Using the FIRETEC modeling system (Linn and Cunningham 2005, Linn et al. 2002), Linn et al. (2010) simulated fire behavior on a 30° slope with different fuel types and found that slope alone has a significant effect on spread rate and spread pattern. This confirms the results of Weise and Biging (1997) and Santoni et al. (1999), but the most significant finding from the FIRETEC simulations was that the spread rate of all simulations is not the same at a point near the bottom of the hill and a point near the top, even though the slope is the same at each point. Linn et al. (2010) remarked that this result indicates that simply having a single value of local slope angle of a hill and a single nominal windspeed is not adequate to predict the spread rates on slopes.

Linn et al. (2007) also showed that under certain conditions, the local slope had a more pronounced effect on spread rate than ambient wind. For example, numerical

simulations showed that fire spread was dominated by the topography at locations on the middle of a slope when ambient winds were 6 m/s, whereas at other locations upwind of the slope, the fire behavior was strongly influenced by the coupling between the topography and ambient wind. This result indicates the importance of understanding the local winds that are influenced by the topography. Although the local wind field drives the fire behavior, topography has a more pronounced effect on the wind field rather than directly on the fire. Additionally, Linn et al. (2007) found a relationship among fire behavior, topography, and atmosphere that showed importance when the topographically influenced winds are not complementary to the slope effects such as those reported by Weise and Biging (1997).

Because present knowledge of fire behavior on slopes and in gullies is a result of laboratory experiments and numerical modeling studies, there is still a large gap in understanding the role of slope-scale winds on fire spread. Therefore, there is an immediate need for well-designed field experiments.

Downslope winds—

Downslope winds, also known as katabatic and drainage winds, develop once the slope becomes shaded as the sun sets. This reversal in heating causes a shallow layer of cold air to develop along the slope, and this cold layer of air is now denser than the surrounding air. As a result, it flows or drains downslope. As with upslope winds, downslope winds are driven primarily by temperature differences between the air on the surface of the slope and that at the same elevation away from the slope. Observations of downslope flows over simple slopes indicate that the velocities range from 1 to 4 m/s and occur within a depth of 10 to 40 m above the slope (Horst and Doran 1986, Papadopoulos and Helmise 1999, Whiteman 2000).

Because downslope winds have limited vertical extent and are typically much weaker in velocity, their effect on fire behavior may be limited. Down-valley winds are most likely to affect fire behavior on mountain valley slopes at night. Down-valley winds typically strengthen throughout the night and overrun the weaker downslope flows.

Once surface winds become decoupled owing to the buildup of a nocturnal inversion at the valley floor, fire behavior can change dramatically with a change in direction or a decrease in spread rate, flame length, and intensity. These changes can also be attributed to relative humidity recovery near the surface.

Valley winds—

Valley winds, also known as along-valley winds, are a much more consistent wind regime than slope flows and are typically associated with much stronger velocities. The dynamic forcing is similar to that of slope winds with the exception that the forcing is driven by a valley volume effect. During daytime, air in the valley is warmer than over the plain because its volume is less and thus it warms faster than air over the plain (Schmidli and Rotunno 2010, Whiteman 1990). As a result, pressure is reduced in the valley while it is higher over the plain at an altitude that is the same elevation as the valley. The pressure gradient force is then directed from the plain to the valley (Whiteman 1990). During the night, the pressure gradient reverses and the

winds blow down valley. Up-valley winds have velocities on the order of 3 to 8 m/s and down-valley winds about 3 to 6 m/s. Typically, there exists an oscillation in the winds at night (Porch et al. 1991), which can affect fire behavior. The oscillations are thought to be caused by the interactions of air flowing out from tributary valleys into the main valley causing surges in the winds to occur at regular intervals on the order of 10 to 20 min. These surges can lead to changes in fire spread rate if the surface wind accelerates. However, there have been no quantitative studies on how the valley wind can affect fire behavior during daytime or night.

Valley winds can sometimes be overcome by other mesoscale wind circulations especially in regions near coastlines. Seto and Clements (2011) observed the formation of a small fire whirl that formed during a prescribed fire when the prevailing up-valley wind was overcome by a sea breeze (fig. 2-2). Observations from a micrometeorological measurement tower placed in the burn unit showed that the fire whirl formed immediately after the sea breeze entered the valley at the surface. The fire whirl was first observed

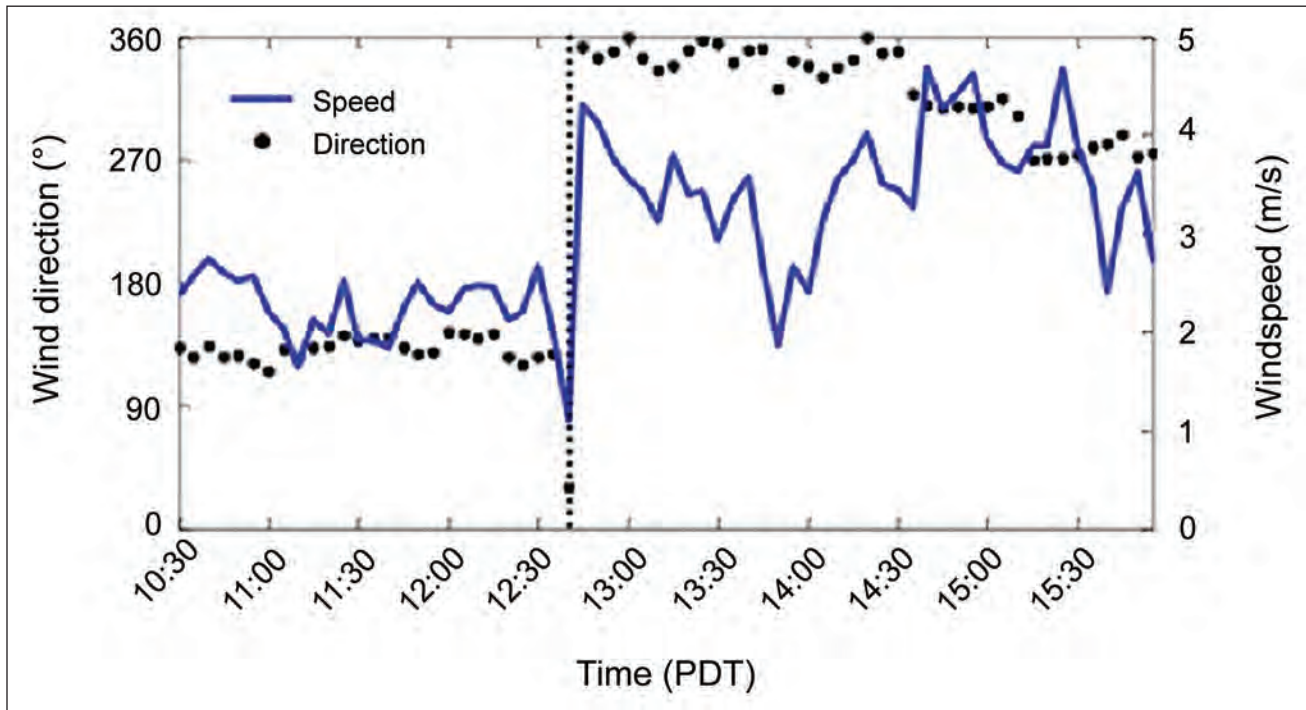

Figure 2-2—Time series of 5 minute averaged windspeed and direction observed during a wind reversal. Southeast up-valley winds reversed with the onset of a northerly sea breeze. Timing of fire whirl is indicated with dashed line. PDT = Pacific Daylight Time.

in the flaming front but moved behind the fire line as it stretched about 200 m in the vertical. The fire whirl caused the fire crew to quickly reposition themselves away from the fireline to remain safe. After the fire whirl dissipated, firing operations resumed. Seto and Clements (2011) ascertained that the fire whirl was caused by horizontal vorticity that was generated as a result of near-surface wind shear formed by the interaction of the sea breeze and the up-valley wind.

Inversion destruction in valleys—

The diurnal evolution of vertical temperature structure in mountain valleys has been well established by extensive field and modeling studies (Whiteman 1982, Whiteman and McKee 1982). Inversion breakup and the transitional period that occurs afterward can produce significant changes in surface conditions such as windspeed, wind direction, temperature, and relative humidity. For these reasons, inversion breakup is likely to produce periods of extreme fire behavior. Whiteman (1982) identified three inversion destruction patterns in mountain valleys, but only two are applicable to fire behavior because the third is associated with snow-covered valleys. The first pattern is associated with one main mechanism, the development of the CBL from the surface. This pattern occurs in wide valleys and is similar to inversion breakup over flat terrain. The second pattern is associated with two processes and is the most common destruction pattern found in valleys around the world. In this pattern, (Whiteman's pattern 3), the inversion top descends into the valley as the CBL continuously grows upward until the descending inversion top and CBL meet at some altitude. The subsidence that occurs is also responsible for transporting heat from the valley sidewalls to the entire valley atmosphere.

Breakup of temperature inversions can occur within 2 to 3 h, depending on valley geometry and season (Whiteman 1990). The most dangerous situation for increased fire behavior occurs when strong windflow above the valley is decoupled from the surface by the inversion's capping top. Once the inversion breaks, momentum of the stronger winds aloft can quickly bring drier and warmer

air to the surface. Windspeed can easily double and shift 180° in direction. This situation is common in valleys and can be anticipated on fires, but the rate of inversion breakup and the decoupling of winds aloft should be estimated from smoke observations or a sounding taken on site.

Whiteman's (1982) inversion breakup model does not apply to every valley. The Riviera Project in the Swiss Alps (Rotach et al. 2004) found that the thermodynamic structure and evolution of inversion breakups in Swiss valleys differed from those studied by Whiteman in the Colorado Rocky Mountain valleys. Rotach et al. (2004) described a valley atmosphere that is stable throughout the afternoon rather than being well mixed as suggested by Whiteman (1982). However, a multilayered structure in temperature profiles has been found in other valleys of the Alps. Thus, the stability regime can be quite different from valley to valley. To determine local stability for fire behavior and fire weather predictions requires an on site sounding at the time of interest.

An example of inversion breakup in a deep valley is shown in figure 2-3 where potential temperature, water vapor mixing ratio, and the up-valley component of windspeed are plotted up to 700 m AGL nearly to the valley crest height of 1000 m AGL. Potential temperature is the temperature that an air parcel would have if it were raised or lowered adiabatically to a reference pressure level, usually 1,000 millibars (mb). Potential temperature (θ) is calculated using the measured temperature (T) in Kelvins (K), and pressure, P , $\theta = T \left(\frac{P_0}{P} \right)^{\frac{R}{C_p}}$ where R is the gas constant for dry air, C_p is the heat capacity, and P_0 is the reference pressure of 1,000 mb. When potential temperature is constant with height, the atmospheric stability is neutral. The atmosphere is considered unstable when potential temperature decreases with height and is stable when potential temperature increases with height. The up-valley wind component is a wind component that is rotated to align with the valley axis. Positive values represent up-valley winds and negative values down-valley winds.

The evolution of this valley's vertical temperature and wind profiles clearly illustrates decoupling of down-valley

winds from the surface. This decoupling results from the strong capping inversion that formed at 80 m AGL while the entire valley was stable (increasing potential temperature with height). The strong and shallow surface inversion (0.07 K/m) remained in nearly steady state during the morning, approximately 2 h, as the down-valley flow (with velocities of approximately 4 to 5 m/s) was decoupled from the surface. This decoupling caused very stagnant atmospheric conditions (cold air pool) at the surface as shown by the very weak winds (<0.5 m/s) within the layer. As the valley atmosphere destabilized (1035 Pacific Standard Time), the winds reversed and became up-valley, but were still weak at the surface. During the transition period between down-valley and up-valley wind regimes, winds can switch direction aloft while remaining constant or weak (fig. 2-2) at the surface. Missing in figure 2-3 is the period where stronger up-valley winds reached the surface. These missing data are a result of the strong turbulence that occurred at the surface making a balloon ascent extremely difficult.

Another aspect of valley inversions is the role they have on the thermal belt. Thermal belts are areas along valley sidewalls that are warmer than the areas below and above

them. This can have an effect on the fuel loading, moisture content, and temperature, and resulting fire behavior.

Cross-valley winds—

Cross-valley winds result from either differential slope heating or dynamically forced flow over the terrain. Additionally, during valley inversion breakup, solar radiation that first illuminates one side of a valley causes a circulation to develop in the across-valley direction. Air within the center of the valley flows toward the heated sidewall and compensates for slope flow and convection that develops in response to solar heating (Colette et al. 2003, Whiteman et al. 2004). Rotach et al. (2004) found that valleys with bends can influence the location of the core of up-valley flow. In the Riviera Valley, the up-valley jet core was located closer to one valley sidewall because of the inertia of the flow as it came around a bend in the valley. This observation suggests that in valleys with sharp bends in the along-valley direction, the flow maxima can occur along one side of the valley. This characteristic can affect fire behavior in valleys by creating stronger surface wind on one side of the valley. If a fire were to cross the valley by spotting, the spread rate could potentially be much different than would be observed on the opposite valley sidewall.

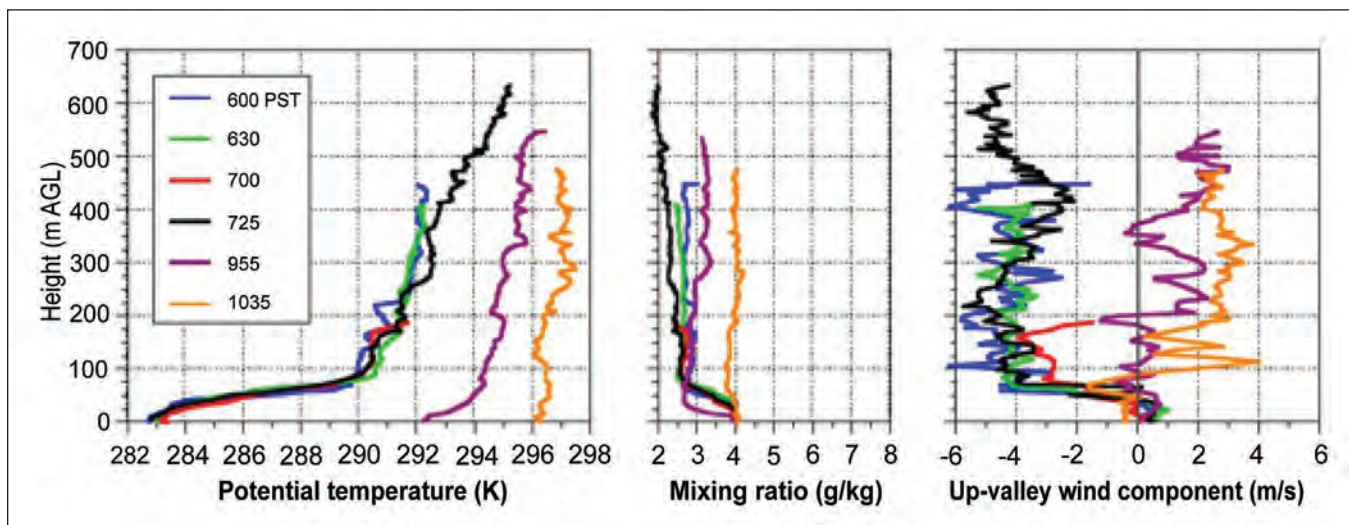

Figure 2-3—Inversion breakup evolution observed by vertical profiles obtained from tethered sonde measurements taken 16 March 1998 in Yosemite Valley California (adapted from Clements and Zhong 2004). AGL = above ground level. PST = Pacific Standard Time. Water vapor mixing ratio is defined as the ratio of the mass of water vapor in grams (g) to the mass of dry air in kilograms (kg), or (g/kg).

Turbulence in mountainous regions—Turbulence is defined as the perturbation from the mean of wind velocity. Little is known about the characteristics of atmospheric turbulent processes in steep mountainous terrain (Weigel et al. 2007). The role of turbulence on fire behavior has been suggested as a critical driving force at the fire front (Taylor et al. 2004) and larger ambient scales (Sun et al. 2009). Both background ambient turbulence and the turbulence generated by the fire itself affect the resulting fire behavior (Sun et al. 2009).

Results from the Alps (Rotach et al. 2004, Weigel et al. 2007) indicate significant spatial variability in surface turbulence characteristics throughout the valley atmosphere, which is largely determined by local topographical features such as slope. The maximum shear-induced turbulence was found to occur on the eastern valley sidewall (sunlit) and near the center of the valley at the core of the valley wind. Turbulence-producing slope surfaces have a significant influence on turbulence structure in large parts of the valley atmosphere. Consequently, fire behavior on slopes can be driven by a combination of slope effects and ambient turbulence that is generated by shear between the slope flow layer and valley wind. As found in the Riviera Valley, turbulence generation can often be dominated by wind shear. Intense turbulence is often associated with strong wind shear generated by strong surface winds such as foehn events (Sharpley et al. 2010b).

Wind Modeling Tools: WindNinja

Determining real-time wind characteristics on incidents in complex terrain remains a challenge. This need has been partially addressed by the development of wind modeling systems by the U.S. Department of Agriculture Forest Service using in-house and commercially available computational fluid dynamics codes. The most popular modeling system is WindNinja (<http://www.firemodels.org>), which is similar to the more complex WindWizard model (Butler et al. 2006). WindNinja uses a wind observation at a location to compute a spatially varying high-resolution (100-m) wind field over the terrain, attempting to account for mechanical modification of the flow by terrain. WindNinja is not a forecasting tool, but rather provides a “snap-shot in time”

of the wind for an area. WindNinja is becoming widely used on fire incidents by incident meteorologists and fire behavior analysts. This is due to the nature of the system—it can be run on a laptop computer, taking less than a minute to provide output. That is a big advantage as no forecasting system can provide this ease of use. Output from WindNinja has value for the user, but there are some major limitations of the system that users should be aware of. Numerics of the system are based on solving a rather simple set of mass continuity equations and optional slope flow equations. This simplicity is what makes WindNinja operate so fast on a laptop. These same simplifications are reason for caution when using it in complex terrain. First, the model is a mass-consistent model requiring air to flow around mountains rather than over them. The major pitfall of this model type is the lack of thermodynamic fields to determine atmospheric stability, which would indicate whether air would flow around or over terrain. The lack of thermodynamics limits its use for situations where thermally driven circulations dominate. The exception is a simple slope flow submodel included in WindNinja. The model stability for flow computation is fixed for a neutral atmosphere (Butler et al. 2006), except in the initialization phase where WindNinja approximates lower atmosphere stability based on surface heat flux and subsequently uses a logarithmic vertical wind profile that includes adjustment for this stability. After the initialization phase, neutral stability is assumed for flow adjustment, but a method of relaxing this is currently being tested² so the current version of WindNinja should not be expected to provide accurate simulations in situations where thermally driven flows dominate. For example, without the ability to run the model with specific stabilities such as a stable layer at crest height, it may not be able to accurately predict wind flow during foehn events because the crest-level inversion is an important criterion for development of downslope windstorms. Also, WindNinja may fail during inversion breakup or when a valley atmosphere is slightly stable during the day. An enhancement currently being tested in WindNinja

² Forthofer, J. 2011. Personal communication. Mechanical engineer, USDA Forest Service, Missoula Fire Sciences Laboratory, Missoula, MT.

is to initialize it with available weather model forecasts from, for example, the National Weather Service (see footnote 2). Initializing WindNinja with coarse forecast model wind fields that already include thermal forcing may alleviate WindNinja's thermal stability issues, resulting in improved downscaled (higher resolution) winds.

Kochanski et al. (2009) used multiple meteorological modeling systems, including WindNinja, to simulate flow over a simple hill. The performance and accuracy of WindNinja were much less than the other models, primarily because the version of WindNinja used did not allow for a user-defined vertical wind profile. Note that the other models used were much more sophisticated and required extensive computing time and processors in order to complete their simulations, whereas WindNinja did not. Forthofer (2007) simulated the same hill using a research version of WindNinja that did specify the measured upwind vertical wind profile and showed much better results upwind and at the top of the hill. Flow on the lee side was less accurate, likely owing to the crude handling of momentum/turbulence in WindNinja, which becomes most important on lee slope locations.

Although there are limitations with this type of modeling system in complex terrain, a user with an understanding of these limitations can run the model to get a general idea of the wind field over a fire area. This can be beneficial when there is a need to determine whether winds in an area are terrain forced and caused solely by topography. Because WindNinja provides a gridded wind field in under 1 minute of simulation time, it is a very capable tool, but users should have an understanding of the issues mentioned above. Finally, in the summer of 2010, a major field validation experiment was conducted to provide a comprehensive data set for testing and improving the WindNinja application (see footnote 2). It is likely to become an improved tool in the future.

Summary

Atmospheric processes in complex and mountainous terrain produce a variety of phenomena that can affect fire behavior in unpredictable ways. Two main wind types should be considered for better predicting fire behavior in

mountainous regions: large-scale dynamically driven winds and thermally driven winds. The most notable dynamically driven winds are the foehn winds that occur in most mountain ranges in the Western United States. Foehn winds are known for increasing surface winds dramatically and causing very rapid warming and drying. The Santa Anas of southern California, associated with extreme windspeeds and drying, have led to flow channeling in narrow canyons resulting in extreme fire behavior and accelerated down canyon fire spread. To date there are few observations of fire-atmosphere interactions and the resulting fire behavior during foehn events. More systematic observations are required to better understand extreme fire behavior during foehn wind.

Thermally driven winds in mountainous terrain occur regularly as they transition from up valley/upslope during the daytime to down valley/downslope at night. Thermally driven winds have weaker windspeeds than dynamically driven winds and can be overcome by synoptic-scale winds aloft when atmospheric stability permits the downward transport of higher momentum into the valley atmosphere. These situations lead to rapid increases in surface winds and fire spread rates.

One of the most critical factors affecting fire behavior in valleys is inversion breakup during the morning transition period. During the morning transition period, stable air at the surface quickly mixes and becomes unstable owing to development of a convective mixed layer over the valley floor. When this occurs, winds above the inversion layer that were decoupled from the surface can mix down quickly bringing much stronger wind velocities to the surface, usually from a different direction. These situations can potentially lead to extreme fire behavior by affecting spread rates and direction. To better anticipate these rapid changes, vertical profiles of temperatures should be measured in real time using radiosonde soundings or remote-sensing temperature profilers. Real-time observations would allow fire crews to know the state of the atmosphere at a given instant.

In addition to the valley inversion breakup, valley geometry can play a role in fire behavior. Valleys with sharp bends can have flow maxima along one side of the valley.

This characteristic can potentially affect fire behavior in valleys by creating stronger surface winds on one side of the valley. If the fire were to spot across the valley, the spread rate could potentially be much different than would be observed on the opposite valley side wall.

Fire behavior on slopes is often explosive in nature as fire accelerates up slope. To date, most studies have used either wind tunnel experiments or coupled atmosphere-fire numerical modeling systems. Results of these studies indicate fire spread rates increase with increasing slope and the fire front shape distorts toward the slope, becoming more pointed. The fire front distortion also increases with increased slope angle. The increase in spread rate on slopes is caused by flame attachment to the fuel bed because the fuel is closer to the flame. Laboratory studies indicate that 24° is a critical angle for flame attachment to occur. Radiative heat transfer is dominant on slopes up to 20°. When slope angle increased from 20° to 30°, convection caused the fire spread rate to increase by a factor of 2.5. Observations in mountainous terrain confirm that slopes with angles over 25° are most prone to flame attachment and explain why observed eruptive fire behavior is prevalent on steep slopes and in canyons.

Because present knowledge of fire behavior on slopes is mainly a result of laboratory experiments and numerical modeling studies, there is still a large gap in understanding the role of slope-scale winds on fire spread on slopes. Numerical studies have shown that terrain has a more pronounced effect on fire spread on slopes than ambient wind. However, there are limited field data to support these results. Therefore, there is an immediate need for well-designed field experiments over sloped terrain to obtain a data set that can be used in model development and validation.

Future Needs

Most fire behavior measurements have been limited to laboratory studies, wind-tunnel experiments, and numerical simulations. There are few, if any, field studies of fire-atmosphere interactions during actual wildland fires (Clements et al. 2007). Therefore, comprehensive field experiments on slopes in mountainous areas need to be conducted to enhance the understanding of how complex terrain

affects fire behavior. The data collected from these experiments can be used to test and develop fire behavior models. Specific experiments needed include:

- Slope experiments with head fires starting on flat terrain and spreading upslope under various fuels and ambient meteorological conditions.
- Head fire experiments in chimneys and steep canyons.
- Experiments during inversion breakup on valley floors to investigate fire behavior during transition periods.

Idealized experiments are limited to smaller scales and do not account for true wildfire conditions. To overcome this, measurements can be made by incident meteorologists at incidents. The National Weather Service Incident Meteorologist program has begun implementing the use of radiosondes on incidents rather than pilot balloons. Having profiles of temperature, humidity, and wind at high temporal and spatial resolution (about 1 s, 2 m) will allow incident meteorologists and fire behavior analysts to determine changes in atmospheric stability on site. Additionally, the use of remote sensing technology should be considered a priority. These sensors include Doppler wind LIDAR and passive microwave temperature and humidity profiles. Although the cost of these technologies is high, the data would provide great insight into the mechanisms of atmospheric dynamics on fire behavior in complex terrain.

Literature Cited

- Atkinson, B.W. 1981.** Meso-scale atmospheric circulations. Maryland Heights, MO: Academic Press. 495 p.
- Baumann-Stanzer, K.; Piringer, M. 2004.** Foehn signals detected by sodar wind and turbulence measurements in the Rhine Valley, Austria, during the MAP field phase. *Meteorology Atmospheric Physics*. 85: 125–139.
- Barry, R.G. 2008.** Mountain weather and climate. 3rd ed. Cambridge, United Kingdom: Cambridge University Press. 506 p.
- Belcher, S.E.; Finnigan J.J.; Harman, I.N. 2008.** Flows through forest canopies in complex terrain. *Ecological Applications*. 18: 1436–1453.

- Blier, W. 1998.** The sundowner winds of Santa Barbara, California. *Weather and Forecasting*. 13: 702–716.
- Brown, H. 2002.** Thirtymile Fire: fire behavior and management response. *Fire Management Today*. 62(3): 23–30.
- Bennett, E.; Brode, R.; Dicke, J.; Eskridge, R.; Garrison, M.; Irwin, J.; Koerber, M.; Lockhart, T.; Method, T.; Perkins, S.; Wilson, R. 1987.** On-site meteorological program guidance for regulatory modeling applications. EPA-450/4-87-013. Research Triangle Park: NC: U.S. Environmental Protection Agency.
- Butler, B.W.; Forthofer, J.M.; Finney, M.A.; Bradshaw, L.S.; Stratton, R. 2006.** High resolution wind direction and speed information for support of fire Operations. In: Aguirre-Bravo, C.; Pellicane, P.J.; Burns, D.P.; Draggan, S., eds. *Monitoring science and technology symposium: unifying knowledge for sustainability in the Western Hemisphere*. Proc. RMRS-P-42CD. Fort Collins, CO: U.S. Department of Agriculture, Forest Service, Rocky Mountain Research Station: 595–602.
- California Department of Forestry and Fire Protection. 2008.** Hatchery Incident Investigation Report, CACSR-000068. Sacramento, CA.
- Cheney, P.; Sullivan, A. 2008.** Grassfires: fuel, weather, and fire behaviour. 2nd ed. Collingwood, Victoria, Australia: CSIRO Publishing. 150 p
- Clark, T.L.; Jenkins, M.A.; Coen, J.; Packham, D. 1996.** A coupled atmosphere-fire model: role of the convective froude number and dynamic fingering at the fireline. *International Journal of Wildland Fire*. 6: 177–190.
- Clements, C.B. 1999.** Mountain and valley winds of Lee Vining Canyon, Sierra Nevada, California, U.S.A. *Arctic, Antarctic, and Alpine Research*. 31: 293–302.
- Clements, C.B.; Heilman, W.E. 2010.** The grass fires on slopes experiment. 14th conference on mountain meteorology. Boston, MA: American Meteorological Society.
- Clements, C.B.; Whiteman, C.D.; Horel, J.D. 2003.** Cold-air-pool structure and evolution in a mountain basin: Peter Sinks, Utah. *Journal of Applied Meteorology*. 42(6): 752–768.
- Clements, C.B.; Zhong, S. 2004.** The role of the topographic amplification factor in the breakup of nocturnal inversions in Yosemite Valley, Sierra Nevada. Unpublished poster presentation at the 11th conference on mountain meteorology. Boston, MA: American Meteorological Society. http://www.met.sjsu.edu/~clements/Clements_Zhong_2004.pdf. (1 June 2011).
- Clements, C.B.; Zhong, S.; Goodrick, S.; Li, J.; Bian, X.; Potter, B.E.; Heilman, W.E.; Charney, J.J.; Perna, R.; Jang, M.; Lee, D.; Patel, M.; Street, S.; Aumann, G. 2007.** Observing the dynamics of wildland grass fires: Fireflux—a field validation experiment. *Bulletin of the American Meteorological Society*. 88(9): 1369–1382.
- Coen, J.L.; Riggan, P.J. 2010.** A landscape-scale wildland fire study using a coupled weather-wildland fire model and airborne remote sensing. Proceedings of 3rd fire behavior and fuels conference. [CD-ROM]. Birmingham, AL: International Association of Wildland Fire. 11 p.
- Colette, A.; Chow, F.K.; Street, R.L. 2003.** A numerical study of inversion layer breakup in idealized valleys and the effects of topographic shading. *Journal of Applied Meteorology*. 42(9): 1255–1272.
- Defant, F. 1949.** Zur Theorie der Hangwinde, nebst Bemerkungen zur Theorie der Berund Talwinde. *Archiv für Meteorologie Geophysik und Bioklimatologie*, A: 421–450. (Translated as “A theory of slope winds, along with remarks on the theory of mountain winds and valley winds.”) In: Whiteman, C.D.; Dreiseitl, E., eds. 1984. *Alpine meteorology*. PNL-5141. ASCOT-84-3. Richland, WA: Battelle, Pacific Northwest Laboratory: 95–120.
- Dold, J. 2010.** Flow attachment in eruptive fire growth. In: Viegas, D.X., ed. Proceedings of the VI international conference on forest fire research. Coimbra, Portugal: Associação para o Desenvolvimento da Aerodinâmica Industrial (ADAI)/ Centro de Estudos sobre Incêndios Florestais (CEIF), Coimbra, Portugal. 10 p.

- Dold, J.W.; Zinoviev, A. 2009.** Fire eruption through intensity and spread rate interaction mediated by flow attachment. *Combustion Theory and Modelling*. 13: 763–793.
- Doran, J.C.; Horst, T.W. 1983b.** Observations and models of simple nocturnal slope flows. *Journal of the Atmospheric Sciences*. 40: 708–717.
- Doran, J.C.; Zhong, S. 2000.** Thermally driven gap winds into the Mexico City basin. *Journal of Applied Meteorology*. 39: 1330–1340.
- Doyle, J.D.; Smith, R.B. 2003.** Mountain waves over the Hohe Tauern: influence of upstream diabatic effects. *Quarterly Journal of the Royal Meteorological Society*. 129: 799–823.
- Dupuy, J.L.; Maréchal J. 2011.** Slope effect on laboratory fire spread: contribution of radiation and convection to fuel bed preheating. *International Journal of Wildland Fire*. 20(2): 289–307.
- Durran, D.R. 1990.** Mountain waves and downslope winds. In: Blumen, B., ed. *Atmospheric processes over complex terrain*. Boston, MA: American Meteorological Society: 59–81.
- Ekhart, E. 1944.** Beiträge zur alpinen Meteorologie [Contributions to alpine meteorology]. *Meteorologische Zeitschrift*. 61(7): 217–231. In: Whiteman, C.D.; Dreiseitl, E., eds. 1984 *Alpine meteorology*. PNL-5141, ASCOT-84-3. Richland, WA: Battelle, Pacific Northwest Laboratory: 45–72.
- Esperanza Investigation Team. 2006.** Esperanza Fire accident investigation factual report, Riverside County, California. http://www.fire.ca.gov/fire_protection/downloads/esperanza_00_complete_final_draft_05_01_2007.pdf. (12 December 2010).
- Forthofer, J.M. 2007.** Modeling wind in complex terrain for use in fire spread prediction. Fort Collins, CO: Colorado State University. 123 p. M.S. thesis.
- Fosberg, M.A.; Schroeder, M.J. 1966.** Marine air penetration in central California. *Journal of Applied Meteorology*. 5: 573–589.
- Gaberšek, S.; Durran, D.R. 2004.** Gap flows through idealized topography. Part I: Forcing by large-scale winds in the non-rotating limit. *Journal of Atmospheric Sciences*. 61: 2846–2862.
- Hill, C.D. 1980.** The effects of terrain distribution on summer thunderstorm activity at Reno, Nevada. Tech. Memo. NWS-WR-156. Reno, NV: National Oceanic and Atmospheric Administration. 34 p.
- Horst, T.W.; Doran, J.C. 1986.** Nocturnal drainage flow on simple slopes. *Boundary-Layer Meteorology*. 34: 263–286.
- Huang, C.; Lin, Y.L.; Kaplan, M.L.; Charney, J.J. 2009.** Synoptic-scale and mesoscale environments conducive to forest fires during the October 2003 extreme fire event in southern California. *Journal of Applied Meteorology and Climatology*. 48: 553–579.
- Hughes, M.; Hall, A. 2009.** Local and synoptic mechanisms causing southern California’s Santa Ana winds. *Climate Dynamics*. 34: 847–857.
- Kingsmill, D. 2000.** Diurnally driven summertime winds in the lee of the Sierra: The Washoe zephyr. Preprints, ninth conference on mountain meteorology. Boston, MA: American Meteorological Society: 109–112.
- Kochanski, A.; Jenkins, M.; Krueger, S.K.; McDermott, R.; Mell, W. 2009.** Capabilities of current wildfire models when simulating topographical flow. *Eos Transactions of the American Geological Society*. 90(52). Fall Meet. Suppl., A41G-05.
- Linn, R.; Reisner, J.; Colman, J.J.; Winterkamp, J. 2002.** Studying wildfire behavior using FIRETEC. *International Journal of Wildland Fire*. 11: 233–246.
- Linn, R.R.; Cunningham, P. 2005.** Numerical simulations of grass fires using a coupled atmosphere-fire model: basic fire behavior and dependence on wind speed. *Journal of Geophysical Research*. 110(D13), D13107. DOI: 10.1029/2004JD005597.

- Linn, R.R.; Winterkamp, J.L.; Edminster, C.; Colman, J.J.; Smith, W.S. 2007.** Coupled influences of topography and wind on wildland fire behaviour. *International Journal of Wildland Fire*. 16: 183–195.
- Linn, R.R.; Winterkamp, J.L.; Weise, D.R.; Edminster, C. 2010.** A numerical study of slope and fuel structure effects on coupled wildfire behaviour. *International Journal of Wildland Fire*. 19: 179–201.
- Mahrt, L. 1982.** Momentum balance of gravity flows. *Journal of Atmospheric Sciences*. 39: 2701–2711.
- Manins, P.C.; Sawford, B.L. 1979.** Katabatic winds: a field case study. *Quarterly Journal of the Royal Meteorological Society*. 105: 1011–1025.
- Maranghides, A.; Mell, W. 2009.** A case study of a community affected by the Witch and Guejito Fires. Tech. Note 1635. Gaithersburg, MD: National Institute of Standards and Technology. 59 p.
- Meybeck, M.; Green, P.; Vörösmarty, C. 2001.** A new typology for mountains and other relief classes. *Mountain Research and Development*. 21(1): 34–45.
- Papadopoulos, K.H.; Helmise, C.G. 1999.** Evening and morning transition of katabatic flows. *Boundary-Layer Meteorology*. 92: 195–227.
- Porch, W.M.; Clements, W.E.; Coulter, R.L. 1991.** Nighttime valley waves. *Journal of Applied Meteorology*. 30: 145–156.
- Raphael, M.N. 2003.** The Santa Ana winds of California. *Earth Interactions*. 7: 1–13.
- Reuten, C.; Steyn, D.; Strawbridge, K.; Bovis, P. 2005.** Observations of the relation between upslope flows and the convective boundary layer in steep terrain. *Boundary-Layer Meteorology*. 116: 37–61.
- Ruscha, C.P., Jr. 1976.** Forecasting the mono wind. Tech. Memo. WR-105. National Oceanic and Atmospheric Administration.
- Ryan, G. 1994.** Climate of Santa Barbara, California. Tech. Memo. NWS WR-225. U.S. Department of Commerce, National Oceanic and Atmospheric Administration. 86 p. [Available from National Technical Information Service, U.S. Department of Commerce, Sills Building, 5285 Port Royal Rd., Springfield, VA 22161.]
- Rotach, M.W.; Calanca, P.; Graziani, G.; Gurtz, J.; Steyn, D.G.; Vogt, R.; Andretta, M.; Christen, A.; Cieslik, S.; Connolly, R.; De Wekker, S.F.J.; Galmarini, S.; Kadygrov, E.N.; Kadygrov, V.; Miller, E.; Neining, B.; Rucker, M.; van Gorsel, E.; Weber, H.; Weiss, A.; Zappa, M. 2004.** Turbulence structure and exchange processes in an Alpine Valley: the Riviera Project. *Bulletin of the American Meteorological Society*. 85(9): 1367–1385.
- Santoni, P.A.; Balbi, J.H.; Dupuy, J.L. 1999.** Dynamic modeling of upslope fire growth. *International Journal of Wildland Fire*. 9(4): 285–292.
- Schmidli, J.; Rotunno, R. 2010.** Mechanisms of along-valley winds and heat exchange over mountainous terrain. *Journal of Atmospheric Sciences*. 67: 3033–3047.
- Seto, D.; Clements, C.B. 2011.** Fire whirl evolution observed during a valley wind-sea breeze reversal. *Journal of Combustion*. Article ID 569475, <http://dx.doi.org/10.1155/2011/569475>. (24 February 2014).
- Sharples, J.J. 2009.** An overview of mountain meteorological effects relevant to fire behaviour and bushfire risk. *International Journal of Wildland Fire*. 18(7): 737–754.
- Sharples, J.; Gill, A.M.; Dold, J.W. 2010a.** The trench effect and eruptive wildfires: lessons from the King’s Cross underground disaster. Proceedings of AFAC 2010 conference, Darwin Australia. <http://www.maths.manchester.ac.uk/~jwd/articles/10-TEaEW.pdf>. (13 May 2011).
- Sharples, J.J.; Mills, G.A.; McRae, R.H.D.; Weber, R.O. 2010b.** Foehn-like winds and elevated fire danger conditions in southeastern Australia. *Journal of Applied Meteorology and Climatology*. 49: 1067–1095.

- Sun, R.; Krueger, S.K.; Jenkins, M.; Zulauf, A; Charney, J.J. 2009.** The importance of fire–atmosphere coupling and boundary-layer turbulence to wildfire spread. *International Journal of Wildland Fire*. 8: 50–60.
- Taylor, S.W.; Wotton, B.M.; Alexander, M.E.; Dalrymple, G.N. 2004.** Variation in wind and crown fire behavior in a northern jack pine-black spruce forest. *Canadian Journal of Forest Research*. 34: 1561–1576.
- Vergeiner, I.; Dreiseitl, E. 1987.** Valley winds and slope winds–observations and elementary thoughts. *Meteorology and Atmospheric Physics*. 36: 264–286.
- Viegas, D.X. 2005.** A mathematical model for forest fire blow-up. *Combustion Science and Technology*. 177: 1–25.
- Viegas, D.X. 2006.** Parametric study of an eruptive fire behaviour model. *International Journal of Wildland Fire*. 15(2): 169–177.
- Viegas, D.X.; Pita, L.P. 2004.** Fire spread in canyons. *International Journal of Wildland Fire*. 13: 253–274.
- Viegas, D.X.; Simeoni, A. 2010.** Eruptive behaviour of forest fires. *Fire Technology*. 47(2): 303.
- Wagner, A. 1938.** Theorie und Beobachtungen der periodischen Gebirgswinde. *Gerlands Beiträge zur Geophysik*, 52: 408–449 (Translated as “Theory and observation of periodic mountain winds.”) In: Whiteman, C.D.; Dreiseitl, E., eds., 1984. *Alpine meteorology*. PNL-5141. ASCOT-84-3. Richland, WA, Battelle, Pacific Northwest Laboratory: 11–44.
- Weigel, A.P.; Chow, F.K.; Rotach, M.W. 2007.** On the nature of turbulent kinetic energy in a steep and narrow alpine valley. *Boundary-Layer Meteorology*. 123: 177–199.
- Weise, D.R.; Biging, G.S. 1996.** Effects of wind velocity and slope on flame properties. *Canadian Journal of Forest Research*. 26(10): 1849–1858.
- Weise, D.R.; Biging, G.S. 1997.** A qualitative comparison of fire spread models incorporating wind and slope effects. *Forest Science*. 43(2): 170–180.
- Whiteman, C.D. 1982.** Breakup of temperature inversions in deep mountain valleys: Part I. Observations. *Journal of Applied Meteorology*. 21: 270–289.
- Whiteman, C.D. 1990.** Observations of thermally developed wind systems in mountainous terrain. Atmospheric processes over complex terrain. *Meteorology Monographs No. 45*. Boston, MA: American Meteorological Society: 5–42.
- Whiteman, C.D. 2000.** Mountain meteorology: fundamentals and applications. New York: Oxford University Press. 355 p.
- Whiteman, C.D.; McKee, T.B. 1982.** Breakup of temperature inversions in deep mountain valleys. Part II. Thermodynamic model. *Journal of Applied Meteorology*. 21: 290–302.
- Whiteman, C.D.; Pospichal, B.; Eisenbach, S.; Weihs, P.; Clements, C.B.; Steinacker, R.; Mursch-Radlgruber, E.; Dorninger, M. 2004.** Inversion breakup in small Rocky Mountain and alpine basins. *Journal of Applied Meteorology*. 43(8): 1069–1082.
- Whiteman, C.D.; Zhong, S. 2008.** Downslope flows on a low-angle slope and their interactions with valley inversions. Part I. Observations. *Journal of Applied Meteorology and Climatology*. 47: 2023–2038.
- Wu, Y.; Xing, H.J.; Atkinson, G. 2000.** Interaction of fire plume with inclined surface. *Fire Safety Journal*. 35: 391–403.
- Zangl, G. 2003.** Orographic gravity waves close to the nonhydrostatic limit of vertical propagation. *Journal of Atmospheric Science*. 60: 2045–2063.
- Zhong, S.; Li, J.; Clements, C.B.; DeWekker, S.; Bian, X. 2008a.** Forcing mechanisms for Washoe zephyr: a daytime downslope wind system in the lee of the Sierra Nevada. *Journal of Applied Meteorology and Climatology*. 47: 339–350.
- Zhong, S.; Li, J.; Whiteman, C.D.; Bian, X.; Yao, W. 2008b.** Climate of high wind events in the Owens Valley, California. *Monthly Weather Review*. 136: 3536–3552.

Chapter 3: Critical Fire Weather Patterns

Paul A. Werth¹

Introduction

Eyewitness accounts in journals and diaries have documented the relationship between weather and large wildland fire for hundreds of years. Survivor statements after the 1871 Chicago, Peshtigo, and Michigan Fires, and the 1894 Hinckley Fire identified hot, dry, and windy conditions as the primary weather elements contributing to the destruction caused by these fires.

In the early 1900s, technological advances in meteorology permitted credible scientific research into weather's influence on wildland fire, most of which was closely tied to the study of historical wildland fires.

Even then it was recognized that there are short periods of one or several days in every fire season when wildland fuels (see chapter 4 for more information on wildland fuels) are unusually susceptible to large fire, and this was primarily dependent upon the weather. Show (1931) referred to these as "dangerous periods."

However, it was not until the 1960s that critical fire weather patterns, producing high fire danger and large wildland fires, were identified for both the United States and Canada.

Syverson (1962) documented the first definition of "critical fire weather patterns" as follows:

Crisis period is defined as the critical day, week or month during which blowup fires are experienced. Further, we might conclude that the period of critical fire weather is the result of that combination of weather patterns that have given rise to this condition and might further result in causing more fires or materially assist their spread.

Current fire behavior training courses define critical fire weather patterns as the atmospheric conditions that encourage extreme fire behavior resulting in large and destructive wildland fires.

Critical Fire Weather Patterns are defined as the atmospheric conditions that encourage extreme fire behavior resulting in large and destructive wildland fires.

Understanding weather's influence on wildland fire is essential for safe and effective fire suppression activities. Fire managers and firefighters should be aware of critical fire weather patterns in their areas and how adverse weather associated with those patterns can produce extreme fire behavior conditions that put firefighters and the general public at risk.

Weather Elements That Promote Extreme Fire Behavior

Early fire weather research focused on individual weather elements that occurred prior to and during large wildland fires. The culmination of these studies identified four critical weather elements common to wildland fires exhibiting extreme fire behavior: low relative humidity (or low atmospheric moisture), strong surface wind, unstable air, and drought.

The four critical weather elements common to wildland fires exhibiting extreme fire behavior are low relative humidity, strong surface wind, unstable air, and drought.

Munns (1921) found that "In months with high vapor pressure (high relative humidity), very few fires occurred, while during months of low vapor pressure (low relative humidity) many bad fires occurred." Separate studies by Hofmann (1923) in Washington and Weidman (1923) in Montana and Idaho concluded that relative humidity is the most important factor in development of dangerous forest fires because it significantly increases the flammability of forest material. In a study of southern Appalachian wildfires, McCarthy (1924) found that relative humidity was

¹ Paul A. Werth is a fire weather meteorologist (retired), Northwest Interagency Coordination Center, 150 SW Harrison Street, Suite 400, Portland, OR 97201.

unusually low on high fire risk days, and that this dry air was advected southward by winds from the interior of the continent. His was also the first study to connect the occurrence of low relative humidity to specific wind directions, and the warming and drying of air within high pressure systems owing to subsidence. A study of Massachusetts forest fires by Stickel (1928) stated, “Relative humidity appears to be the best single indication of forest fire hazard.” He also indicated that “The maximum forest fire hazard occurred between rainy periods, when the relative humidity is 40 percent or less.” Dague (1930) identified relative humidity of 20 percent as the point below which bad fire weather situations were created east of the Cascade Mountains in Washington and Oregon. Since that time, numerous wildland fire reports have substantiated the importance of unusually low relative humidity in the development of extreme fire behavior. Regional threshold values for low relative humidity can range between 10 and 40 percent, depending on fuel model.

Low relative humidity (low atmospheric moisture) intensifies fire behavior by decreasing the moisture content of fine dead fuels, making them easier to ignite and carry fire. Fire line intensity (kW/m), rate of spread (ROS) (m/s), and the probability of spotting significantly increase when the relative humidity is low, sometimes so rapidly that there is little advance warning.

The relationship between strong surface wind and large fires exhibiting extreme fire behavior has been well documented for hundreds of years. The first scientific research connecting the two was conducted by Beals (1914). He researched surface atmospheric pressure patterns and associated weather conditions during four large fires (1881 Michigan, 1884 Hinckley, 1902 Columbia, and the 1910 Great Idaho) and found that “The one striking feature of all large forest fires is the strong winds that prevail just before, during, and for a short period after the fire passes a given place.”

Subsequent fire weather research (Anderson 1968; Brotak 1979; Countryman et al. 1956; Dague 1930, 1934; Gisborne 1927; Goens and Andrews 1998; Hoenisch 2009; Hughs and Hall 2009; Jemison 1932; Joy 1923; Kauffman 1937; Krumm 1954; Schaefer 1957; Simard et al. 1983; USDA, USDI, and USDC 1994) has documented strong

cold front, thunderstorm, and foehn winds with the occurrence of extreme fire behavior conditions. (Note: For more information concerning foehn winds, see chapter 2.) Wind affects wildland fire in a number of ways. It supplies additional oxygen to the fire, increasing fire intensity. It also preheats the fuels ahead of the fire and increases ROS by carrying heat and burning embers to new fuels (spotting).

Until the U.S. Weather Bureau established a national network of radiosonde stations, fire weather research was limited to studying only the effects of surface weather on fire behavior. With the advent of radiosonde data, researchers were also able to investigate the influence of upper air temperature, relative humidity, and wind on wildland fire behavior. The concept of airmass stability was discovered through the analysis of vertical temperature profiles. When temperature decreases rapidly with height, the atmosphere is classified as unstable. If there is an increase, or only a slight decrease in temperature with height, the atmosphere is classified as stable. Crosby (1949) was the first to suggest the effect of atmospheric stability on fire behavior. He concluded that stable air dampened convection currents over a fire, whereas unstable air increased the speed and depth of the convection currents. Brown (1950) stated that the stability of the air at the location of a fire is as important to fire behavior as temperature and humidity. Byram (1954) and Byram and Nelson (1951) studied 17 severe fires around the county and identified unstable air and certain vertical wind profiles as being favorable for extreme fire behavior. Davis (1969) investigated 70 fires in the Southeastern United States and found that instability increases the chance of a big fire more often than low relative humidity. Haines (1988) developed a lower atmosphere severity index based on the stability and moisture content of the lower atmosphere. The drier and more unstable the airmass becomes, the higher the Haines Index, and the greater the threat of large wildland fire and extreme fire behavior. Brotak (1992–1993) found that in the Eastern United States, strong surface wind in conjunction with low fuel moisture caused more fire-control problems than unstable air. Werth and Ochoa (1990), Saltenberger and Barker (1993), and Goens and Andrews (1998) found good correlation between the Haines Index

and extreme fire behavior on fires in Idaho, central Oregon, and Arizona.

In summary, unstable air amplifies the vertical growth of the smoke plume over a fire by enhancing the strength of the updrafts. This increases combustion rates by supplying more oxygen to the fire. As the height and strength of the smoke plume increases, the potential for gusty surface winds, dust devils, and fire whirls also increases. Spotting may become profuse all around the fire as large firebrands are lifted in the smoke plume. (Note: For more information concerning the effects of atmospheric stability on extreme fire behavior, see chapters 6 through 8.) Unstable air also increases the probability of thunderstorms and strong downdraft winds.

Beals (1916) defined drought as “Long-continued dry weather, especially so long continued as to cause vegetation to wither.” Beals also stated that while “Drought and periods of hot weather contribute to the fire hazard, these alone do not necessarily portend the occurrence of a great fire, as without wind an incipient fire would spread slowly.” He recognized that drought and hot weather do not necessarily result in large fires, but a critical weather element, such as strong wind, is also needed to produce a large fire. Today drought is defined as **a period of relatively long duration with substantially below-normal precipitation, usually occurring over a large area.** Drought affects fuel availability by lowering the moisture content of both live and dead fuels, making them more combustible. Drought conditions are **not** a prerequisite for large fires, but there is a close relationship between drought conditions, large wildland fires, and extreme fire behavior when low relative humidity and either strong wind or unstable air are present.

Critical Fire Weather Patterns

Critical fire weather patterns occur when atmospheric conditions combine to significantly increase the threat of destructive wildland fires that exhibit extreme fire behavior. Fire weather research has identified adverse atmospheric conditions as strong wind, unusually low relative humidity, and unstable air. Drought is also included as a significant factor, but is the result of a lack of precipitation over a period of weeks, months, or even years.

Beals (1914) researched the September 1, 1894, Minnesota Hinkley Fire in which 418 people perished. He was a pioneer in studying synoptic weather maps depicting pressure, temperature, and wind patterns associated with large fires. On the Hinkley Fire, the weather map (fig. 3-1) showed a surface low pressure center in North Dakota and tightly packed isobars favoring strong wind in Minnesota. It should be noted that his map does not depict cold and warm fronts because frontal theory was not discovered until 1917 by Norwegian meteorologists Vilhelm and Jacob Bjerknes.

In a much later study, Haines and Sando (1969) researched weather conditions during seven large fires in the Great Lakes States in 1871, 1881, 1894, 1910, and 1918. In their report, they included the 8 October 1871 surface weather map at the time the Chicago, Michigan, and Peshtigo Fires were actively burning. This map indicates a weather pattern similar to the one Beals found during the Hinkley Fire, but with the addition of surface fronts. The Haines and Sando map shows a surface low over southwestern Minnesota with a warm front across northern Wisconsin and Upper Michigan. A cold front extends southward from the low center across eastern Iowa. Their conclusion was that all of these fires actively burned in the warm sector of the surface low, in an area experiencing strong southerly winds and unusually low relative humidity. The Hinkley Fire likely also burned in the warm sector of a strong surface low pressure system (fig. 3-1).

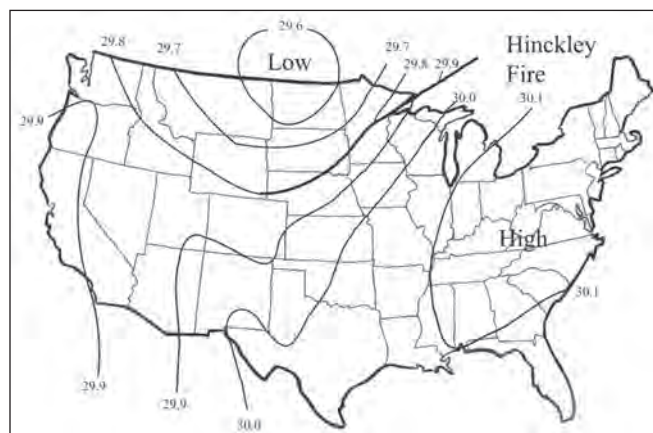

Figure 3-1—Surface pressure map, 01 September 1894 at 0800 Central Standard Time. (Adapted from Beals 1914.)

Show (1931) was the first to document weather being largely responsible for dangerous fire conditions when he wrote, “It was generally recognized that occasionally in every fire season there occurred short periods of one or several days when the forest cover was unusually flammable and at times seemed almost explosive.” He concluded, “Abnormal weather conditions were responsible for these periods.”

The relationship between synoptic weather patterns and high fire danger was further advanced by Schroeder (1950). He noted that for the Great Lakes States in May, “Nearly all of the critical periods were associated with an area of high pressure which developed near the western shore of Hudson Bay and subsequently moved either southward or southeastward.”

An early definition of a critical fire weather pattern was provided by Syverson (1962) when he described it as a “crisis period.” He stated, “A crisis period is defined as: the critical day, week or month during which blow-up fires are experienced.”

Syverson (1963) expanded his concept of a crisis period in an investigation of synoptic fire weather types of the Northern Intermountain, Northern Rockies, and the North-western Plains regions. He selected synoptic weather types (upper air 500 hPa and surface) that contributed to high fire potential or large forest fires. The 500 hPa upper air patterns were divided into meridional, zonal, short-wave train, and high-low block categories. The surface patterns were classified according to the origin of the surface anticyclones (high pressure) affecting the area. Syverson concluded, “The greatest danger occurs just ahead of the upper trough in the area of the low pressure at the surface.”

The most complete research of critical fire weather patterns was published by Schroeder et al. (1964) in *Synoptic Weather Types Associated With Critical Fire Weather*. This study covered all the lower 48 states and determined: “Periods of critical fire weather are associated with relatively few synoptic weather patterns.” They concluded that east of the Rocky Mountains, most critical fire weather patterns are associated with the periphery of high-pressure areas, particularly in the prefrontal and postfrontal areas. Along

the eastern slopes of the Rocky Mountains, weather patterns producing Chinook winds are the most important. In the intermountain West, critical fire weather is associated with upper troughs and overhead jet streams, or surface dry cold front passages. Along the Pacific Coast, from Washington to California, weather patterns producing offshore flow or foehn wind are the most important.

East of the Rocky Mountains, most critical fire weather patterns are associated with the periphery of high-pressure areas, particularly in the prefrontal and postfrontal areas. Along the eastern slopes of the Rocky Mountains, weather patterns producing Chinook winds are the most important. In the intermountain West, critical fire weather is associated with upper troughs and overhead jet streams, or surface dry cold front passages. Along the Pacific Coast, from Washington to California, weather patterns producing foehn wind are the most important.

Brotak and Reifsynder (1977b) detailed the relationship of Central and Eastern U.S. wildland fires with surface frontal systems and upper level troughs and ridges. They found that just prior to and after passage of cold fronts (fig. 3-2) were favored areas for large fire growth to occur. At 500 hPa, the favored area was between the upper ridge and trough axis (fig. 3-3).

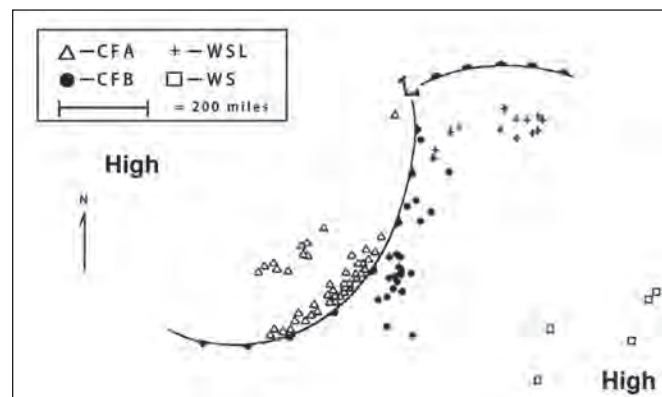

Figure 3-2—Idealized surface map showing all fire runs. CFA= following cold frontal passage; CFB = preceding cold frontal passage; WSL= warm sector of low; and WS = warm sector of high. Source: Brotak and Reifsynder 1977b.

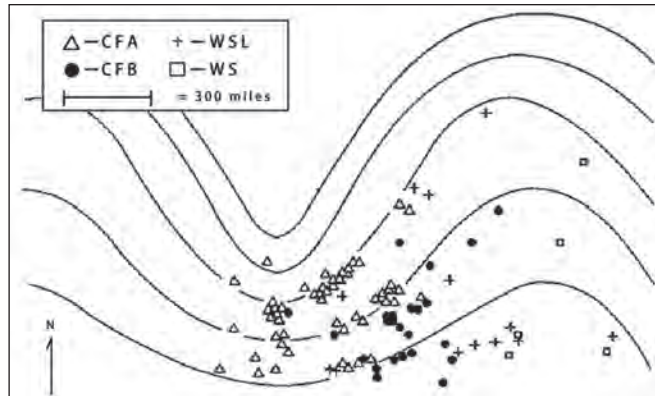

Figure 3-3—Idealized 500 hPa geopotential height map showing all fire runs. CFA = following cold frontal passage; CFB = preceding cold frontal passage; WSL= warm sector of low; and WS = warm sector of high. Source: Brotak and Reifsnyder 1977b.

Nimchuk (1983) documented the relationship between the breakdown of a blocking upper level ridge and severe fire behavior conditions in western Canada. He concluded that the trigger for extreme fire behavior was the breakdown of the upper ridge, rather than the presence of a persistent upper ridge. His statements concerning the fire behavior associated with the three stages in the life cycle of an upper ridge are of particular interest (fig. 3-4).

1. An establishment period characterized by warm, dry stable conditions, low humidity, light wind, rapidly decreasing fuel moisture, and low lightning risk.
2. Initial weakening of upper level disturbances, leading to decreased atmospheric stability and increased lightning activity, but little or no cooling or reduction in fire danger.

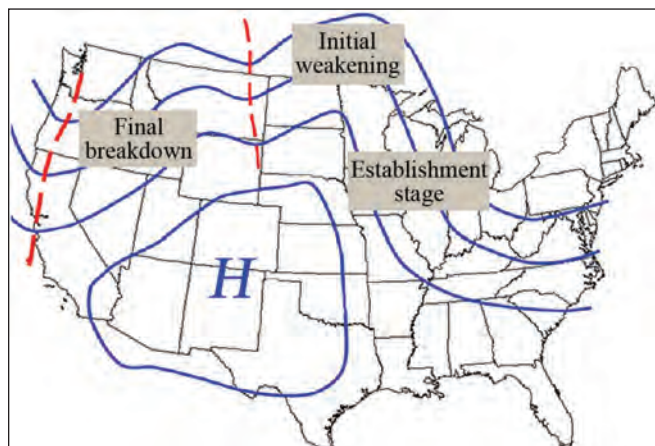

Figure 3-4—Life cycle stages of an upper level ridge.

3. Final breakdown, accompanied by a period of severe burning conditions, strong winds, and lightning followed by cooling and a reduction in fire danger.

In summary, these studies indicate that most periods of critical fire weather occur in transition zones between high- and low-pressure systems, both at the surface and in the upper air. The surface pressure patterns of most concern are those associated with cold fronts and terrain-induced foehn winds. Cold front passages are important to firefighters because of strong, shifting winds and unstable air that can enhance the smoke column, or produce thunderstorms. Foehn winds occur on the lee side of mountain ranges and are typically very strong, often occurring suddenly with drastic warming and drying. The area between the upper ridge and upper trough is the most critical upper air pattern because of unstable air and strong winds aloft that descend to ground level.

Regional Critical Fire Weather Patterns

The following section will briefly describe critical fire weather patterns by region and season. Critical fire weather patterns can be separated into two primary categories:

- Those that produce strong surface wind.
- Those that produce atmospheric instability.

In both cases, an unusually dry airmass, for the region and season, must also occur. Strong wind with high relative humidity is not a critical fire weather situation nor is unstable air combined with high relative humidity.

When critical fire weather patterns occur during periods of drought, the threat of extreme fire behavior significantly increases in brush and timber fuels. However, in grass fuels, some of the worst fire behavior has occurred in moist periods owing to increased fuel loadings. The key to identifying a critical fire weather pattern is the recognition that these patterns must also produce unusually low relative humidity for the region, along with strong surface wind or unstable air.

Northern Plains, Great Lakes, and the Northeastern United States

The fire season in this region primarily occurs before green-up in the spring and after leaf drop in the fall. The spring season can start as early as March in the Northern Plains and the Ohio River Valley and as late as April in the Great Lakes and Northeast States. The fall season can last through November.

Critical fire weather patterns in this part of the country are identified by the source of surface high-pressure areas before or after the passage of cold fronts. That is because the source of these high-pressure areas determines the moisture content of the airmass and whether passing cold fronts will be wet or dry. There are three surface high-pressure types that can produce critical fire weather and extreme fire behavior in this region.

Pacific High—

This high pressure originates over the Pacific Ocean and loses much of its moisture as it crosses the Rocky Mountains. It moves into the Northern Plains and Great Lakes States with a dry continental airmass. This is the most common type and shows little preference for any particular month.

Northwest Canadian High—

This high pressure is normally warm and dry owing to its source region, subsidence warming, and southward movement over warmer land. Critical fire weather occurs on the periphery of the high, especially the north and northwest sides. This type occurs during the spring and fall.

Hudson Bay High—

This is similar to the Northwest Canadian High. The most critical fire weather is on the northwest side of the high. However, dry cold fronts can produce extreme fire behavior, both before and after frontal passage. Schroeder (1950) identified the Hudson Bay High as the principal weather type associated with periods of very high fire danger for the Great Lakes States.

Brotak (1979) analyzed the weather and fire behavior conditions during the 22 July 1977, Bass River Fire in New Jersey. The fire claimed the lives of four firefighters when

flames overran their position. Drought, strong wind, unusually low relative humidity, and extreme instability contributed to the extreme fire behavior experienced during the fire. The extreme fire behavior occurred after the passage of a cold front and in the southeast quadrant of a Hudson Bay high-pressure area (fig. 3-5). The 500 hPa map (fig. 3-6) shows an upper level trough over New Jersey and a northwesterly flow of subsiding air in the leading edge of high pressure over the Great Lakes.

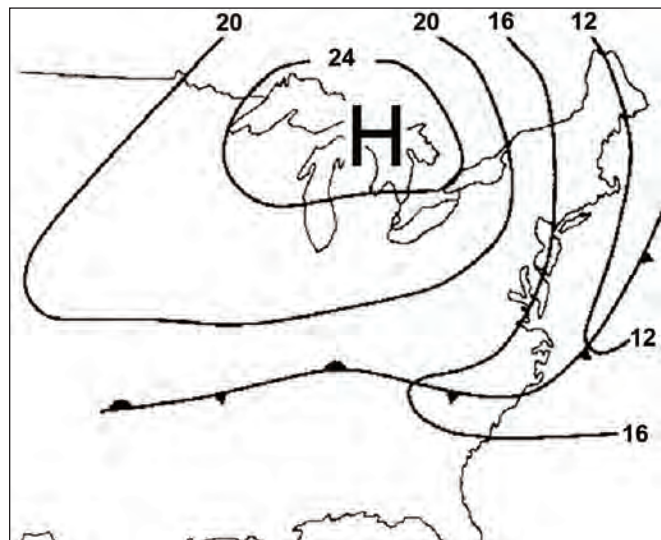

Figure 3-5—1400 Eastern Daylight Time, surface weather map. Source: Brotak 1979.

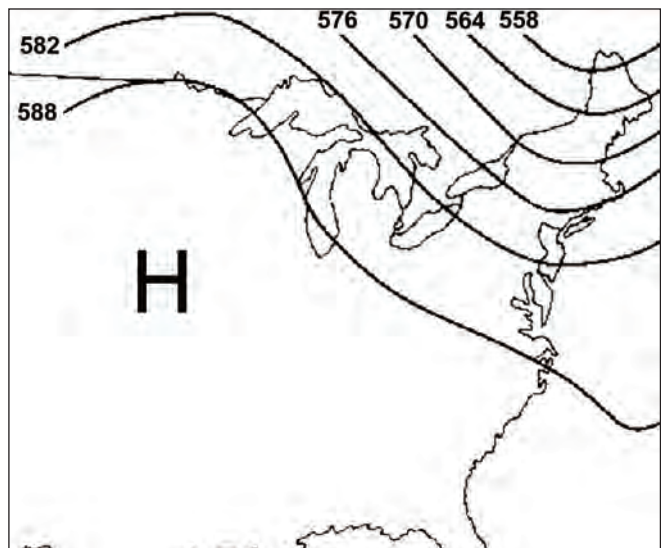

Figure 3-6—0800 Eastern Standard Time, 500 hPa geopotential height map. Source: Brotak 1979.

Simard et al. (1983) researched the weather, topography, fuels, and fire behavior of the May 5, 1980, Mack Lake Fire in Michigan. They concluded that the extreme fire behavior observed on the Mack Lake Fire occurred as follows:

“Ahead of the weak cold front (fig. 3-7), relative humidity was low at 24 percent, and the temperature was unseasonably high at 26.7 deg C (80 deg F). Wind speed (at the Mio weather station) increased significantly to 24 km/h (15 mi/h), gusting to 40 km/h (25 mi/h) plus as the front approached.” This is a classic prefrontal critical fire weather pattern during the spring months for the Great Lakes States.

The August 25, 1995, Sunrise Fire on Long Island, New York, is another example of a fire that burned during a postfrontal critical fire weather pattern, with north winds and a relative humidity of less than 20 percent reported. It burned approximately 2800 ha and damaged numerous homes and small businesses.

Southeastern United States

The Southeastern United States encompasses an area from eastern Oklahoma and eastern Texas, eastward across the lower Mississippi Valley and the Gulf States, to the Atlantic coast from North Carolina to Florida. Fire season in the Southeast is typically during the spring and fall. However,

wildland fires do occur at other times of the year. The spring fire season occurs in the weeks before green-up. This usually begins during March near the Carolina and Georgia coast and the Gulf States. The fall fire season occurs in October and November, normally after the first frost. Oklahoma and Texas are typically dry in late winter, and large grass fires are not uncommon in February. The Florida season may extend through the winter and spring well into June, especially during periods of drought. Critical fire weather patterns in this region are those that produce low relative humidity, and either strong surface wind or unstable air.

McCarthy (1923), in a study of fire weather in the southern Appalachian Mountains, observed “Low vapor pressure (related to low dew point and low relative humidity) usually accompanies high atmospheric pressure and seems to be induced by prevailing wind from the west or northwesterly directions, while south or easterly winds tend to increase the humidity.”

McCarthy (1924) further stated, “Winds, coming from the interior of the continent and warming as they move southward, are usually low in humidity, a condition which is increased by the downward convection of cold air in the high pressure zone which warms as it approaches the surface.”

Williams and Smith (1962) documented the weather and fire behavior associated with the March 1953 Brasstown Fire in South Carolina. They determined that the fire’s large growth and extreme fire behavior occurred after the passage of a cold front when northwesterly winds brought dry air from Canada and the Great Lakes.

Early fire case studies concluded that high fire activity in the Southeast is more often associated with surface high-pressure systems that originate in Canada or those that move across the Rocky Mountains from the Pacific Ocean. The important characteristic of these high-pressure systems is the dry air that replaces the moist Gulf of Mexico or Atlantic Ocean airmass, which normally covers this part of the country.

The movement of surface high-pressure systems is dependent upon the upper level windflow. For that reason, it is difficult to discuss critical fire weather patterns without

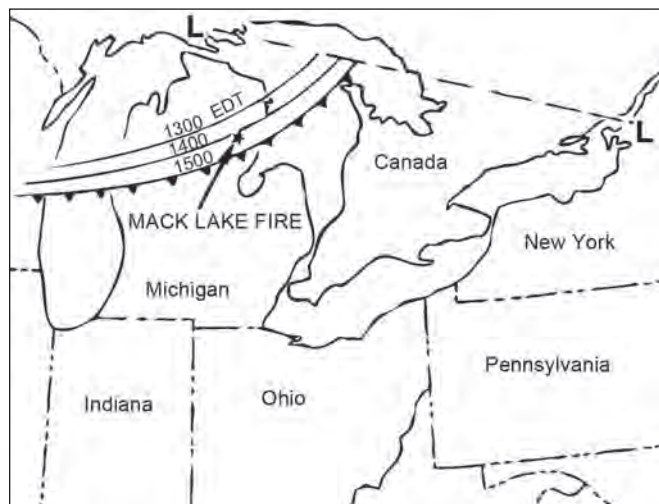

Figure 3-7—Cold frontal positions during the Mack Lake Fire. Source: Simard et al.1983.

linking the surface features to upper level pressure patterns. Three upper level patterns are effective in keeping the Southeast under the influence of high pressure at the surface. If the antecedent condition of below normal rainfall is in place, a critical fire weather pattern emerges.

Strong westerly flow—

During the spring and fall, strong westerly winds aloft result in a rapid succession of Pacific fronts traversing the Southeast. Little, if any, moisture from the Gulf of Mexico is able to return to the region in advance of these cold fronts. Rainfall with the front is sparse and light. Exceptionally low relative humidity may occur the day after frontal passage, and little recovery can be expected before the next front arrives. Strong and gusty winds are a distinct possibility.

Northwesterly flow—

Dry air, associated with Canadian high-pressure systems, can spread across the Southeast during the spring and fall. The initial Canadian cold front moves through the Southeast and remains stationary far south of the region until the upper level pattern changes. A large and stagnant high-pressure system settles over the region. Weak fronts from the north may reinforce the dry airmass. Relative humidity may not be quite as low as with Pacific fronts, and better humidity recovery can be expected at night. Strong northwest to north winds often occur as the surface high pressure pushes into the Southeast.

Blocking ridge aloft—

This pattern occurs when high pressure aloft persists near the Atlantic coast for an extended period of time, possibly for a few weeks. Weather systems from the west or north are blocked from moving through the region. Little or no rainfall is produced during the period that the upper level ridge is in place.

In addition to the upper level patterns, extreme fire behavior can also occur in advance of a tropical storm owing to subsidence-produced dry air and a strong wind area that extends beyond the cloud and rain shield.

Critical fire weather patterns should be carefully examined for the presence of strong low-level jets (i.e., reverse

wind profile). Research conducted by Byram (1954) showed a strong connection between low-level jets and extreme fire behavior in the Southeast. (Note: For more information concerning low-level jets and adverse wind profiles, see chapter 6.)

The combination of extreme drought and critical fire weather patterns was a major factor in the severe 1998 Florida wildland fire season. Fires in the northern and central portions of the state experienced major fire runs on July 4, driven by strong westerly winds and unusually low relative humidity of 30 percent or less (fig. 3-8). The source of the dry air was the Great Plains, the dry air being pushed into Florida by a northwesterly upper level windflow (fig. 3-9).

Southwestern United States

The Southwestern region includes the states of Arizona, New Mexico, and west Texas. The normal fire season spans the months of May to October but can extend throughout the year in the grasslands of eastern New Mexico and western Texas.

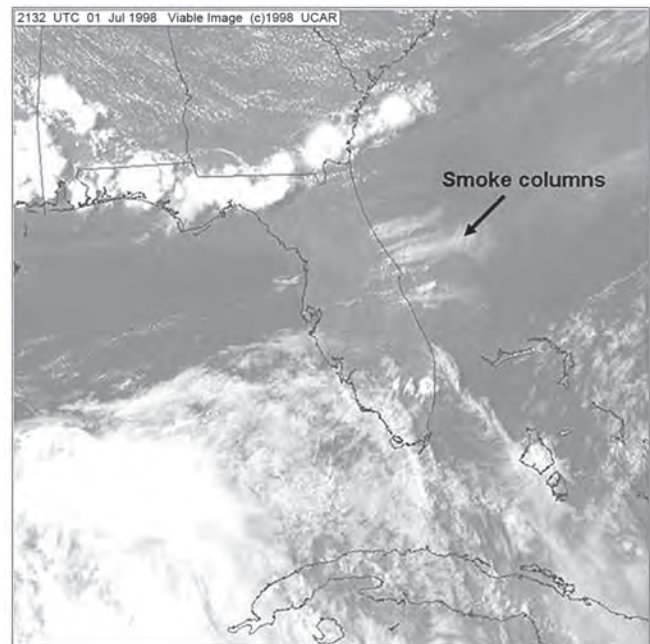

Figure 3-8—Visible satellite picture 2132 Coordinated Universal Time, 01 July 1998, shows strong, dry westerly wind pushing smoke columns from central Florida wildfires out over the Atlantic Ocean. (National Oceanic and Atmospheric Administration and University Corporation for Atmospheric Research.)

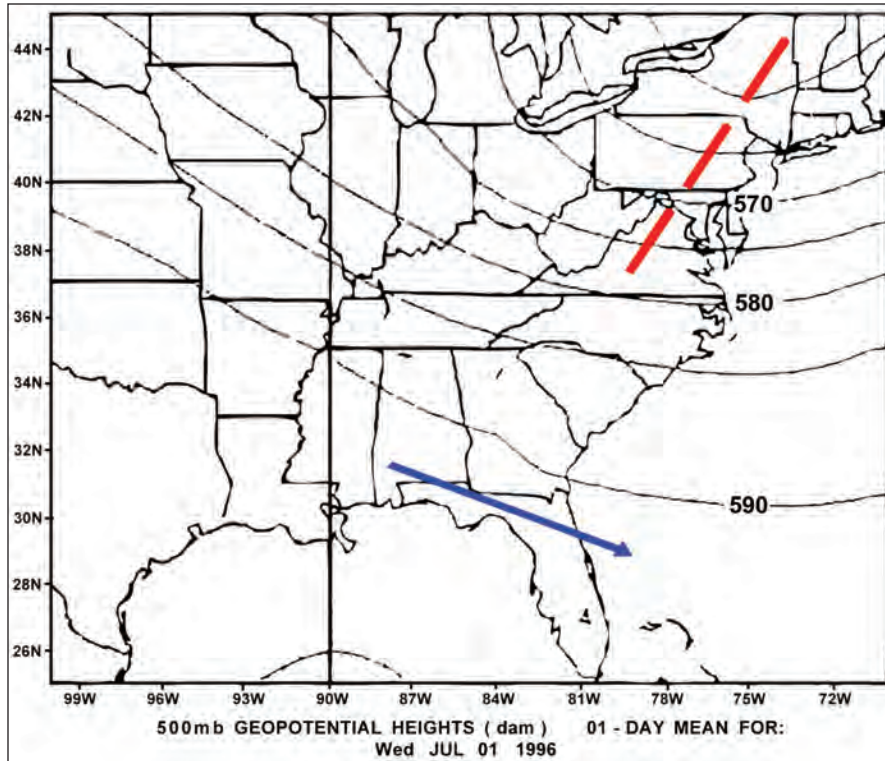

Figure 3-9—500 hPa geopotential height map indicating northwesterly flow aloft over Florida. (National Oceanic and Atmospheric Administration, National Centers for Environmental Prediction/National Center for Atmospheric Research reanalysis.)

Crimmins (2005) examined the seasonal climatology of extreme fire weather conditions across Arizona and New Mexico during the period 1988–2003. He found that there are three key upper level patterns associated with over 80 percent of the extreme fire-weather days identified in this study. These upper level patterns represent broad southwesterly flow and large geopotential height gradients and are very similar to the critical fire weather patterns identified by Schroeder et al. (1964). All three of these upper level patterns are consistent with the breakdown of the upper level ridge critical fire weather pattern defined earlier.

The major critical fire weather patterns of the Southwest are listed below.

Breakdown of Upper Ridge—

This is the most prevalent pattern in the Southwest, as a mean 500 hPa ridge is frequently positioned over the area during the fire season. From late spring through the early summer, upper level troughs moving inland from the Pacific Ocean are strong enough to temporarily push the upper ridge east and south of the area. These upper troughs are

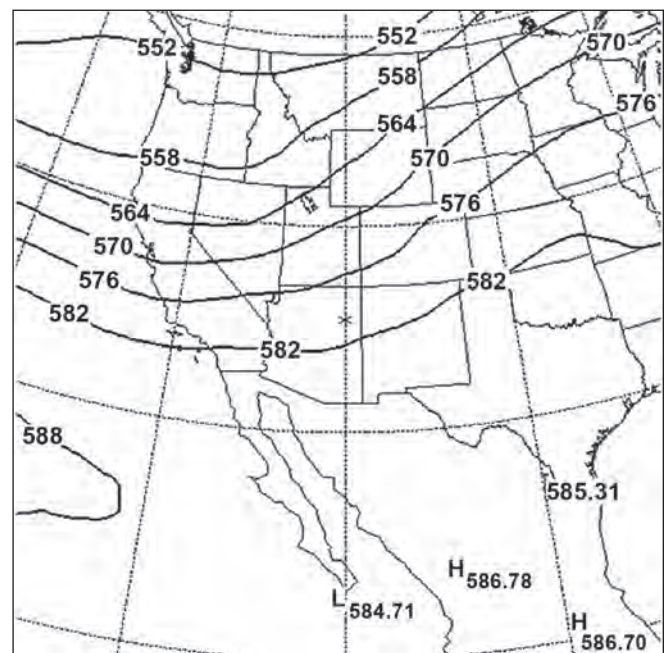

Figure 3-10—07 May 2000, 500 hPa geopotential height map. (National Oceanic and Atmospheric Administration, National Centers for Environmental Prediction/National Center for Atmospheric Research reanalysis.)

manifest at the surface as dry, cold fronts, which produce strong winds, very low relative humidity, and isolated dry lightning. The airmass becomes unstable as the upper level trough approaches, resulting in moderate to high Haines Index values. Strong upper level winds will frequently mix down to the surface, producing winds of 60 to 80 km/h. The peak fire season ends when these upper troughs stay well to the north and the southwest monsoon becomes fully developed.

The May 7, 2000, Cerro Grande Fire in New Mexico exhibited extreme fire behavior owing to a critical fire weather pattern known as the breakdown of the upper level ridge. A strong upper level trough (fig. 3-10) was moving into Arizona and New Mexico, pushing a ridge that had been over the area into Texas and Oklahoma. Strong southwest surface winds (fig. 3-11) were experienced on the fire with gusts up to 120 km/h. Drought conditions and

extremely low relative humidity also contributed to the extreme fire behavior. The final size of the fire was 20 000 ha and 235 homes were burned.

Early stage monsoon—

The onset of the southwest monsoon can present an opportunity for extreme fire behavior owing to the combination of gusty wind, low relative humidity, and dry lightning-induced fire starts. As the mean 500 hPa ridge builds north in June and early July, moisture begins to increase at mid-levels while surface conditions remain hot and dry. The speed and strength at which the monsoon develops determine the severity of this pattern. If the monsoon starts slowly, there may be enough dry lightning to overwhelm local fire management resources. If it develops quickly, dry storms will rapidly become rain producers and effectively end the fire season. When surface dew points rise to 10 to 15 °C, the majority of storms will be wet.



Figure 3-11—07 May 2000, visible satellite picture showing well-defined smoke plume driven by strong southwest winds. (National Oceanic and Atmospheric Administration, National Weather Service.)

Lee surface trough/dryline—

This pattern occurs in eastern New Mexico and western Texas in advance of an approaching upper level trough. Well ahead of the upper trough, a north-south dryline develops in the surface pressure pattern that sharply divides moist air to the east and dry air to west. The passage of a dryline is similar to that of a dry cold front. Strong, gusty southwest winds develop and surface dewpoint temperatures drop from 10 to 20 °C to -5 to -10 °C. This results in very low relative humidity and rapidly drying fuels. Dry, windy conditions behind a dryline can last for hours until the trailing cold front moves through with much cooler temperatures, higher relative humidity, and decreasing west to northwest winds.

A classic example of the lee surface trough/dryline critical fire weather pattern occurred on February 27, 2011, in west Texas when wildfires burned thousands of hectares and numerous structures, and caused the evacuation of thousands of people. The upper level pattern consisted of a 500-hPa low pressure center along the southern California/Arizona border with a jet stream ahead of the low over New Mexico and west Texas (fig. 3-12). The surface pattern (fig. 3-13) indicated a cold front across New Mexico and a dryline in west Texas, both moving toward the east. Figure

3-14 displays both the cold front and dryline superimposed on the visible satellite picture. Very low relative humidity values of 5 to 15 percent were observed in west Texas between the dryline and the cold front. The Haines Index map that morning (fig. 3-15) indicated values of 6 across west Texas and extreme eastern New Mexico. This critical fire weather pattern produced strong southwesterly winds, very low relative humidity and dry, unstable air over west Texas resulting in extreme fire behavior on many of these wildfires.

Rocky Mountain and Intermountain Regions

These two regions cover much of the interior Western United States. The Rocky Mountain region includes the states of Montana, Wyoming, Colorado, and northern Idaho. The Intermountain region comprises the states of Nevada, Utah, and southern Idaho. The fire season ranges from May through October in the southern and June through October in the northern portions of these regions. However, in the grasslands of eastern Colorado, eastern Wyoming, and eastern Montana, it may start as early as February or March prior to green-up.

A considerable amount of fire weather research has been conducted in these regions, beginning with the historic

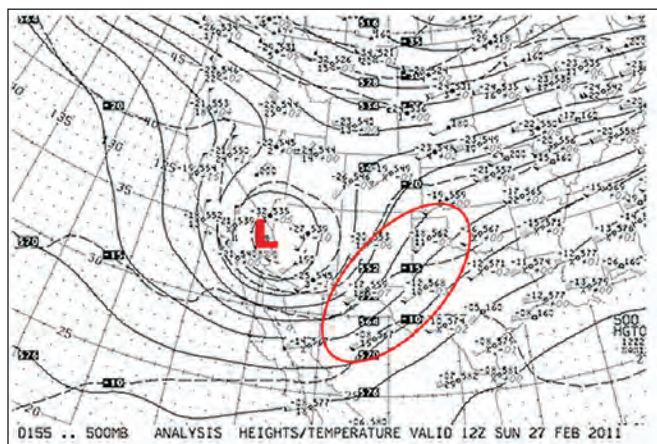

Figure 3-12—1200 Coordinated Universal Time, 27 February 2011, 500 hPa geopotential height map showing an upper level low system centered along the California/Arizona border and strong jet stream winds over New Mexico and West Texas. (National Oceanic and Atmospheric Administration, National Weather Service.)

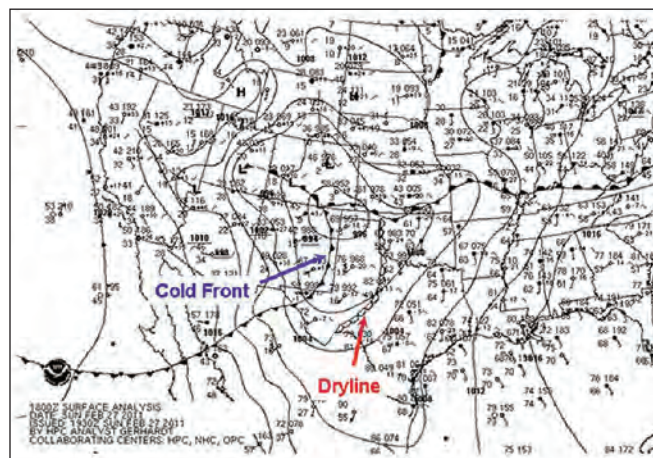

Figure 3-13—1800 Coordinated Universal Time, 27 February 2011, surface pressure map showing a cold front in extreme eastern New Mexico and a dryline in central Texas. The dryline marks the boundary between very dry air in western Texas and moist air located across eastern Texas (National Oceanic and Atmospheric Administration, National Weather Service.)

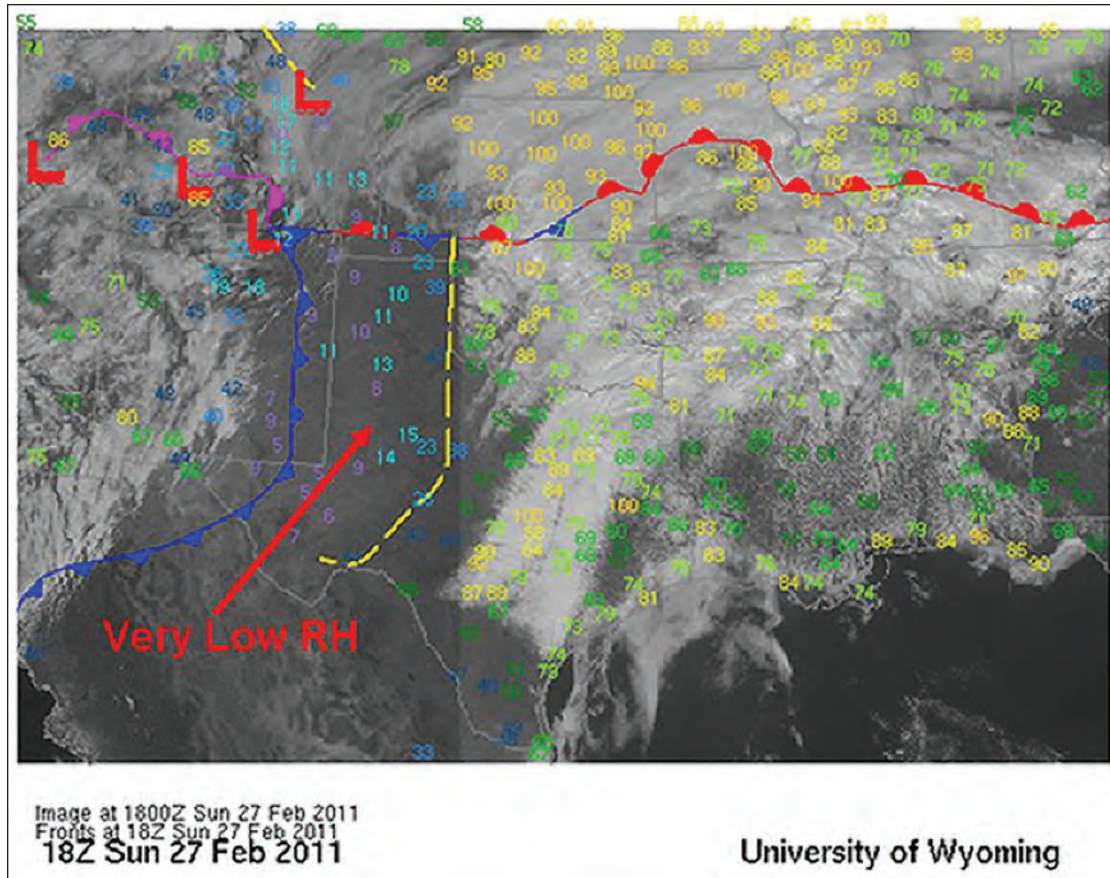

Figure 3-14—1800 Coordinated Universal Time, 27 February 2011, visible satellite picture with superimposed cold front and dryline. Relative humidity in the teens and subteens and zero cloud cover indicate the presence of very dry air over western Texas, an area between the dryline (yellow dashed line) and cold front (blue line with triangles). (National Oceanic and Atmospheric Administration, National Weather Service, and the University of Wyoming.)

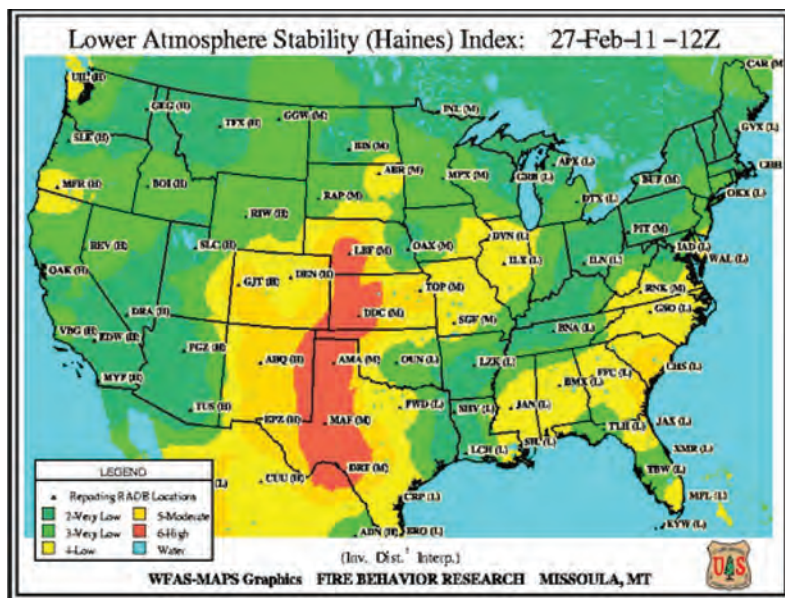

Figure 3-15—1200 Coordinated Universal Time, 27 February 2011, Haines Index map. An area of Haines Index 6 (dry, unstable air) covers extreme eastern New Mexico and western Texas. (USDA Forest Service, Wildland Fire Assessment System.)

1910 Great Idaho Fire. Beals (1914) studied this fire that burned over 800 000 ha in Idaho and Montana and caused 85 fatalities. He noted, “There were many fires burning in northern Idaho, but they were kept under fair control until August 20, when a hot, high wind from the southwest began to blow. They burned so furiously that nothing could be done to stop them.”

Syverson (1962, 1963, 1964) researched and identified a number of critical fire weather patterns in the Northern Rocky and Intermountain regions as part of a “Nationwide Study of Synoptic Fire Weather Types” project spearheaded by Schroeder, Glovinsky, Hendricks, and others. He studied weather patterns on days when the fire danger was high or days of large fire activity and concluded that:

- The area of high fire danger is almost always on the southwest or west side of the high-pressure cell at the surface.
- The greatest danger occurs just ahead of the upper trough in the area of the low pressure at the surface.
- The breakdown of this type (high pressure) comes with a strong upper air impulse of cooler air moving through from the Pacific.

Syverson’s conclusions agree very well with what occurs during the breakdown of the upper level ridge critical fire weather pattern.

Anderson (1968) examined the weather and fire environment conditions during the September 1, 1967, major run of the Sundance Fire in northern Idaho. He found that the extreme fire behavior on this fire occurred with strong winds and low relative humidity in the prefrontal area ahead of an advancing cold front.

Werth and Ochoa (1993) documented the weather and fire behavior that occurred on the 1988 Willis Gulch and 1989 Lowman Fires in central Idaho. The breakdown of the upper level ridge critical fire weather pattern was identified as significantly contributing to extreme fire behavior observed on both fires. They concluded that this pattern consisted of both upper level and surface pressure pattern components (fig. 3-16) that resulted in high Haines Index values. These index values correlated well with the ROS for both fires, validating the usefulness of the Haines Index.

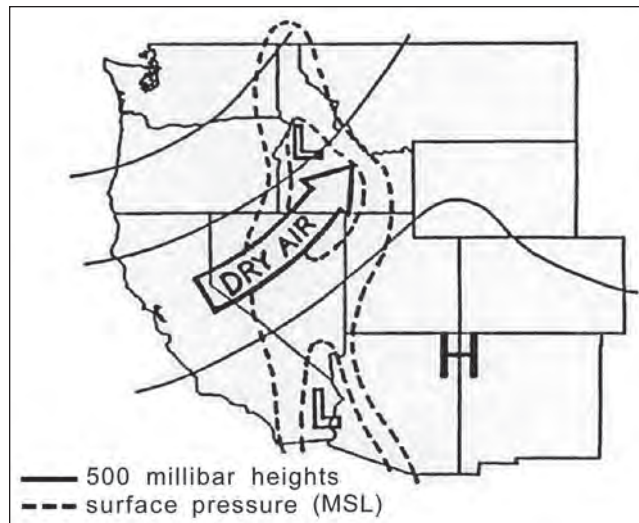

Figure 3-16—Typical 500 hPa and surface pressure pattern associated with the breakdown of the upper ridge critical fire weather pattern. Pattern is also favorable for moderate to high Haines Index values. Source: Werth and Ochoa 1993.

The transition zone, between an upper level ridge and upper trough, and in an area defined by the surface thermal low-pressure trough, is a favored location for moderate and high Haines Index values.

Gibson (1996) found that the breakdown of the upper ridge critical fire weather pattern was present with major increases in area burned on wildland fires in the Northern Rocky region. Gibson stated, “The pattern develops as the normal upper level ridge is shoved east by an approaching shortwave trough.”

In a study of lightning-induced wildfires in Nevada, Miline (2006) found that two weather patterns account for all 17 of the major outbreaks over a 9-year sample period. The “monsoon pattern” accounted for 7 of the 17 events and is characterized by high pressure centered over northern Utah and southern Idaho. With this pattern, warm, moist air originating in the Gulf of California is advected northward into Nevada, triggering thunderstorms. The second and more significant pattern involves a negatively tilted shortwave trough moving northeastward from the eastern Pacific Ocean into north-central California and through northern Nevada and southern Oregon.

The following is a brief summary of critical fire weather patterns in the Rocky Mountain and Intermountain regions.

Upper ridge-surface thermal trough—

This is the most significant pattern for these regions. It is characterized by a strong north-south upper ridge along 105 to 110 degrees west longitude and a hot, dry surface thermal trough extending from central California to eastern Washington or Idaho. High fire danger results when a weak mid- to upper level trough moves up the west side of the ridge, producing dry lightning in the vicinity of the thermal trough. If the upper trough is strong enough, the upper ridge will break down and the thermal trough will shift eastward across the area. A dry and windy surface cold front then follows the thermal trough, producing very high fire danger and increasing the threat of extreme fire behavior on ongoing wildland fires.

Early stage monsoon—

This pattern occurs with an upper level ridge around 105 degrees west longitude and an upper trough off the Pacific coast. It results in dry lightning and gusty winds over the southern parts of these regions.

Foehn wind/Chinook wind—

These strong downslope winds, along the eastern slopes of the Rocky Mountains, are unusually warm and dry for the season. This pattern occurs when strong jet-stream winds blow perpendicular to the mountains and the airmass is stable. They are most pronounced in the winter and spring, but can occur during the fall. When the upper level windflow is from the southwest, the onset of Chinook winds is often prior to the passage of a weak cold front. When the flow is northwesterly, the strong wind begins after frontal passage.

The 1994 South Canyon Fire in western Colorado is a good example of a fire that burned during a breakdown of the upper ridge critical fire weather pattern. On the afternoon of July 6, the fire rapidly transitioned from a surface to a crown fire during the passage of a dry cold front. Tragically, 14 firefighters perished when the fire overran their position. The upper level pattern that afternoon (fig. 3-17) showed a low center in northwestern Wyoming and a trough southward along the Colorado/Utah border. This low pressure system replaced an upper ridge that had been previously over Colorado. A surface cold front moved across the fire site earlier in the afternoon and at 1800 Mountain

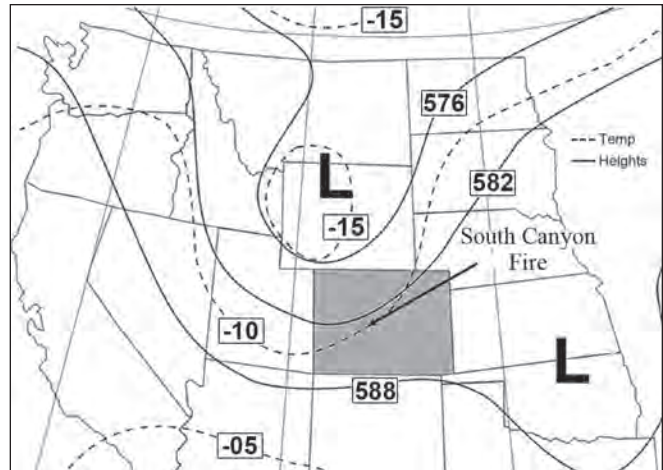

Figure 3-17—1800 Mountain Daylight Time, 06 July 1994, 500 hPa map. Source: USDA et al. 1994.

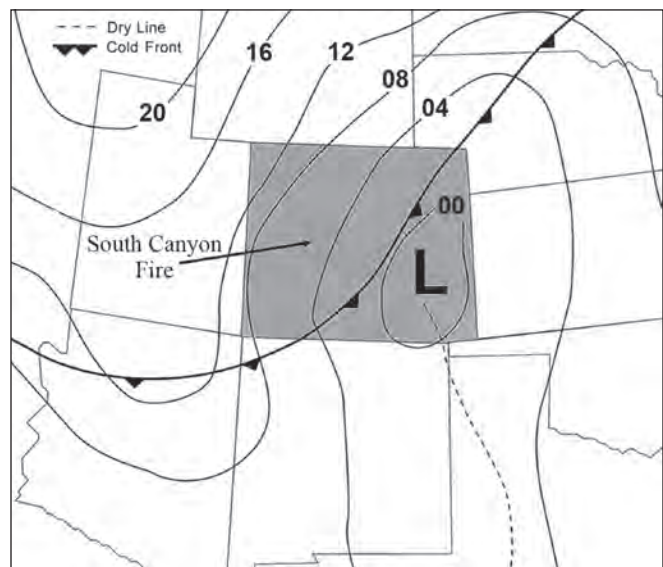

Figure 3-18—1800 Mountain Daylight Time, 06 July 1994, surface map. Source: USDA et al. 1994.

Daylight Time (MDT) was located in eastern Colorado (fig. 3-18). This weather pattern not only produced strong, gusty winds and unusually low relative humidity (<10 percent), but also very unstable air. Fuels were also especially dry owing to long-term drought.

The September 6–7, 1988, extreme fire behavior exhibited on the Yellowstone National Park (northwest Wyoming) and Canyon Creek (Montana) Fires also occurred during a breakdown of the upper level ridge. An upper level trough and a strong west-to-northwest jet stream (fig. 3-19) pro-

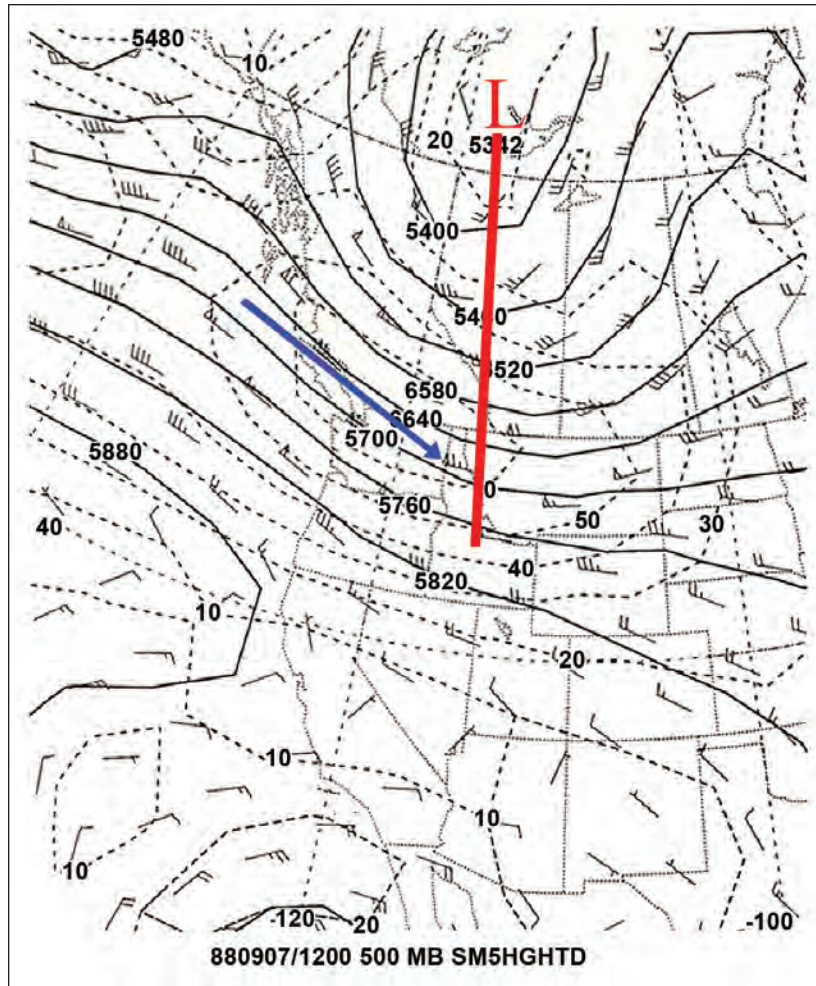

Figure 3-19—1200 Coordinated Universal Time 07 September 1988, 500 hPa geopotential height map showing a trough (red line) over Alberta, Canada, and a strong northwesterly jet stream (blue line) over Idaho, Montana and Wyoming. (National Oceanic and Atmospheric Administration, National Weather Service.)

duced winds in excess of 80 km/h, unusually low relative humidity, and major crowning on both of these wildland fires. The passage of two cold fronts (fig. 3-20) added to the severity of the weather pattern. A Chinook wind developed in Montana, pushing the Canyon Creek Fire well east of the Continental Divide. Long-term drought was also a major factor.

Pacific Northwest Region

The Pacific Northwest region comprises the states of Washington and Oregon. The typical fire season is short compared to other regions and extends from June through early October.

There are two critical fire weather patterns in this region, foehn or east winds in western Washington and

western Oregon, and the breakdown of the upper ridge from the crest of the Cascade Mountains eastward across eastern Washington and eastern Oregon.

East winds were recognized as a fire problem west of the Cascades from the beginning of fire weather research. Beals (1914) and Joy (1923) noted that large fires west of the Cascades were caused by strong east winds that were unusually hot and dry for the area. They also noted that these strong winds occurred when there was high pressure east of the Cascades and low pressure west of the Cascades.

Dague (1934) documented weather during the August 1933 Great Tillamook Fire that burned 105 880 ha in western Oregon. He stated, “Low relative humidity, fresh to strong easterly winds, and high temperatures were responsible for this huge fire.” Dague also observed that a surface

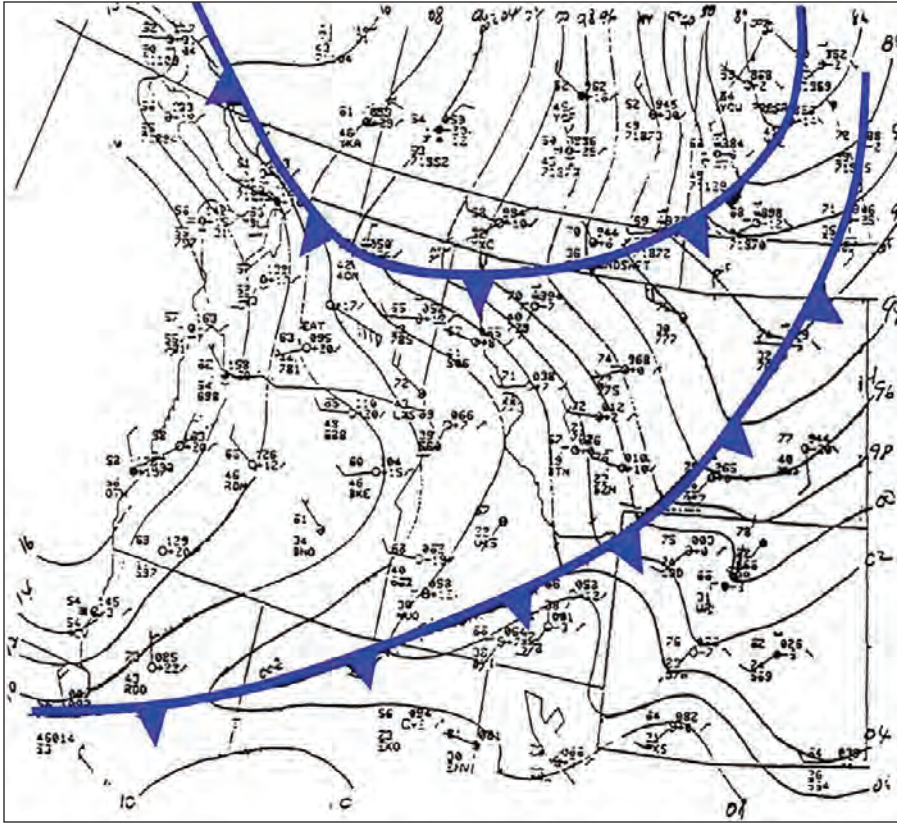

Figure 3-20—1200 Coordinated Universal Time, 07 September 1988, surface pressure map showing cold fronts over northwestern Wyoming along the Canadian/United States border. Source: National Weather Service 1993.

low-pressure trough west of the Cascades contributed to the strength of these winds, and the trough pushed northward from the interior of California.

Saltenberger and Barker (1993) researched weather and extreme fire behavior conditions during the August 4–5, 1990, Awbrey Hall Fire in central Oregon. They concluded that the plume-dominated wildfire became severe owing to a combination of fuels and weather, noting, “The Haines Index performed well. When the index indicated moderate to high growth potential the fire displayed extreme behavior and rapid growth.”

In a study of lightning-induced wildland fires in the Pacific Northwest, Rorig and Ferguson (1999) discovered that there were distinctly different weather patterns between dry and wet thunderstorm days. The pattern for dry days showed an upper trough near the coast and a pronounced thermal trough at the surface in eastern Washington and eastern Oregon (near the Idaho border). Wet-pattern days show a deeper upper trough (much lower geopotential

heights) and a weak surface thermal trough in southern Idaho and eastern Nevada.

Critical fire weather patterns of the Pacific Northwest are detailed below.

Foehn wind/east wind—

Severe east wind patterns occur when surface high pressure pushes inland behind the passage of a cold front and becomes centered over eastern Washington, Idaho, or western Montana. Meanwhile, the California surface thermal trough pushes northward along the Oregon and Washington coasts (fig. 3-21). This pressure pattern produces strong pressure differences (gradients) across western Washington and western Oregon, resulting in offshore flow and northeast-to-east winds of 80 to 100 km/h through the Columbia Gorge and the ridges and passes of the Cascade and coastal mountains. Subsidence also results in warming and drying of the airmass, and relative humidity can drop to 10 percent or lower. The combination of strong wind and unusually low relative humidity often results in wind-driven fires and

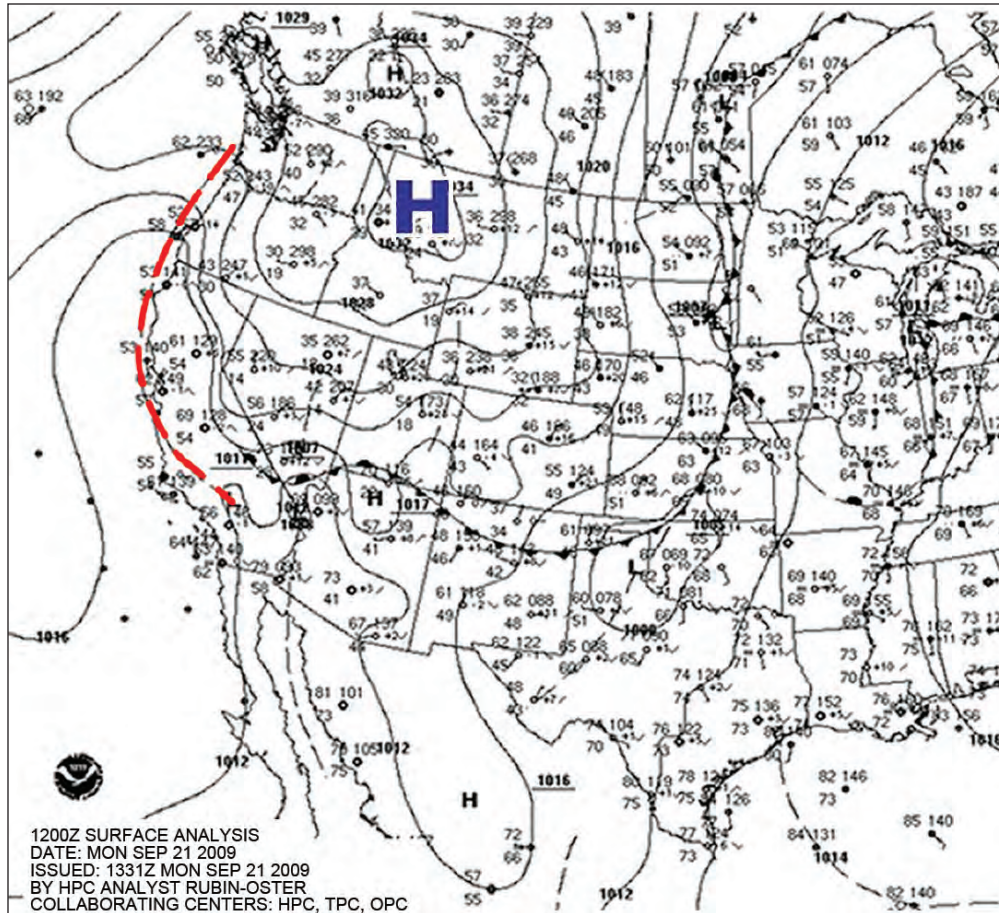

Figure 3-21—East wind surface pressure pattern with a thermal trough just off the Coast and a high centered over Idaho and western Montana. Pattern produces strong pressure gradients and strong winds from the crest of the Cascades to the Coast. (National Oceanic and Atmospheric Administration, National Weather Service.)

extreme fire behavior. The upper level pattern (fig. 3-22) shows a strong high amplitude ridge off the coast between 130 and 140 degrees west longitude. The east wind pattern normally ends when the upper ridge moves inland and the surface thermal trough either dissipates or pushes east of the Cascades. This pattern typically occurs during September and early October and often represents the peak of the fire season west of the Cascades.

Upper ridge breakdown—

This is similar to the type previously described for the Rocky Mountain and Intermountain regions. In this case, the pattern is shifted farther west so the southwest flow is over Oregon and Washington. This pattern occurs when an upper level trough approaches the coast pushing the upper ridge to the east. Cooling aloft results in unstable air and an increased risk of lightning. If the airmass is dry, moderate

to high Haines Index values and dry lightning are possible. The upper level winds will frequently mix to the surface, resulting in strong gusty winds. Meanwhile, the surface thermal trough will shift eastward across the area increasing the threat of extreme fire behavior on new and ongoing wildland fires.

California Region

The fire season extends from mid-May through October in northern California and from late March through December in southern California. However, during drought years, the season in southern California can extend throughout the year.

Krumm (1954) examined the meteorological conditions that affected the July 9, 1953, Rattlesnake Fire in northern California. Fifteen firefighters were killed on this fire. He determined that strong downslope winds occurred on

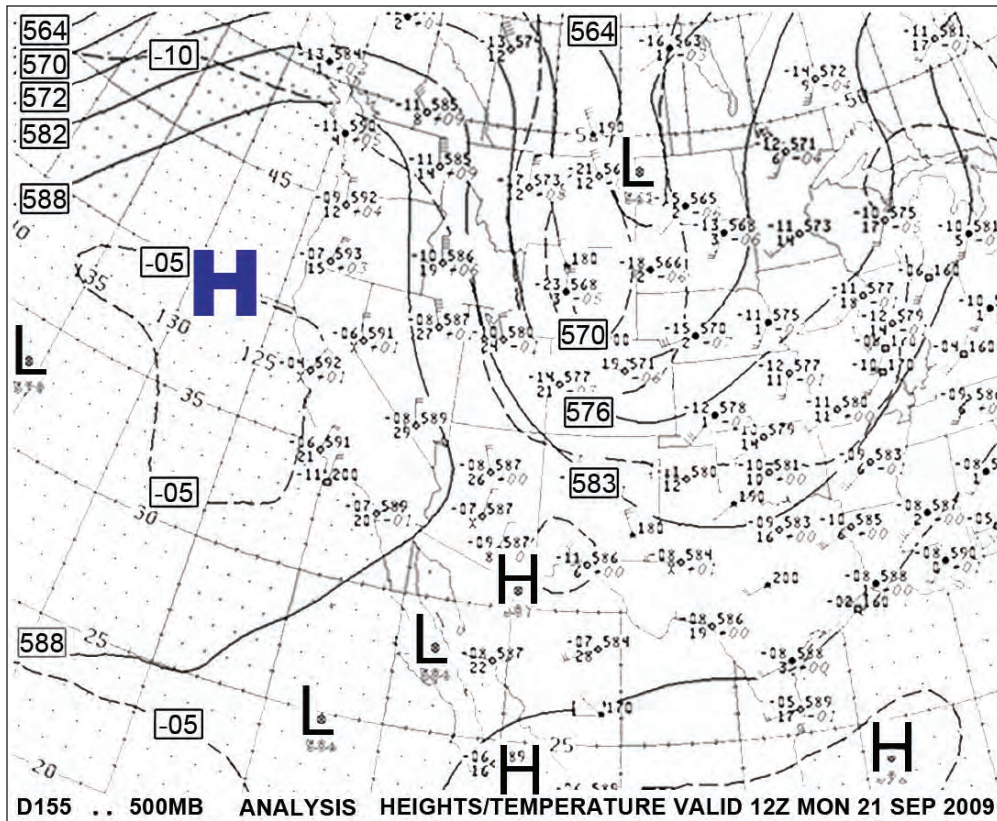

Figure 3-22—Typical east wind 500 hPa geopotential height pattern with strong ridge off the Washington and Oregon coasts. (National Oceanic and Atmospheric Administration, National Weather Service.)

the fire after sunset, caused by a strong pressure gradient between surface high pressure along the Pacific coast and a thermal trough over the Sacramento Valley. This wind develops and descends to the surface similar to other foehn winds with low relative humidity and warm temperatures.

Weather, fuels, and fire behavior of the 1956 Inaja Fire were researched by Countryman et al. (1956) to determine what caused the firefighter fatalities during the fire’s major run. They determined that the fire burned during a Santa Ana wind event in a very wind-prone canyon in the San Diego area.

Ortel (1964) studied serious fire weather conditions in northern and central California as part of a nationwide study of synoptic fire weather types. He identified five weather patterns of concern: an upper level high over the Southwestern States, an upper high over the Pacific Ocean, an upper trough offshore near 130 degrees west longitude, surface cold fronts, and easterly winds from surface high-pressure systems over the Great Basin.

The following is a summary of critical fire weather patterns in California.

Foehn winds/north and mono winds—

This is the most common critical fire weather pattern in northern and central California. These strong, dry winds occur when surface high pressure builds into the Pacific Northwest, resulting in large pressure differences (gradients) across northern California. Dry air moves from Oregon southward into the Sacramento Valley with additional warming and drying. Relative humidity of 10 percent or less with temperatures of 43 °C (110 °F) can occur in the valley under these conditions. Windspeed strength depends on the pressure gradient, upper level windflow, and local topography. When the upper wind flow is from the north or northeast, windspeed values in excess of 65 km/h often occur. Mono winds are strong easterly winds that occur along the western slopes of the Sierra Nevada Mountains. They are similar to the above-mentioned North winds, but

in this case, the center of the surface high pressure is located in Nevada and Utah. This is primarily a late summer and fall pattern, but can occur at other times during the year if the fuels are dry.

Foehn winds/Santa Ana and sundowner winds—

This is the primary critical fire weather pattern for southern California. The pattern develops when surface high pressure builds over Nevada, Utah, and northern Arizona after the passage of an upper level trough. Meanwhile, an upper ridge of high pressure builds off the Pacific Northwest coast. North to northeasterly flow around the upper ridge results in cold air advection and strengthening of the surface high over the Great Basin. High pressure over Nevada and low pressure along the California coast result in strong pressure gradients over southern California. As a result, strong north to east winds develop from the crest of the mountains into the coastal areas. Air descending from higher to lower elevations causes compressional heating, which results in dramatic heating and drying of the air. When Santa Ana winds occur, extreme fire behavior conditions can suddenly develop as relative humidity drops to 10 percent or less and winds increase to 80 km/h or more. Winds can be substantially stronger in mountain passes and canyons. These winds are typically strongest at night and during the morning hours, and diminish somewhat during the afternoon owing to surface heating. This pattern occurs most often during the fall and winter months.

A sundowner wind is an offshore northerly foehn wind that occurs in the lee of the Santa Ynez Mountains, which rise directly behind Santa Barbara and the surrounding coastal area. They develop when high pressure at the surface is centered over the Pacific Northwest and northern California and pressure gradients are perpendicular to the east-west axis of the Santa Ynez Mountains. These winds often precede Santa Ana events by a day or two. The normal progression is for the surface high pressure to migrate into the Great Basin causing pressure gradients and winds to shift more to the northeast and east ending the sundowner winds. (for more information on Santa Ana and sundowner winds, see chapter 2.)

The October 2007 siege of wildland fires in southern California is a good example of a Santa Ana critical fire

weather pattern. These massive wildfires burned hundreds of thousands of hectares, displaced nearly a million people, destroyed thousands of homes, and resulted in 10 fatalities.

The surface and upper level pressure patterns are shown in figures 3-23 and 3-24. Strong surface high pressure was centered over Utah and Nevada, and an upper ridge was located off the California coast. A satellite picture (fig. 3-25) shows numerous smoke plumes being driven off the coast by northeast to east winds. Surface winds in excess of 80 km/h and relative humidity of less than 10 percent were reported on the fires.

Subtropical high aloft—

This pattern occurs when the westerlies shift northward, causing a closed subtropical high to become centered over the Southwest. The upper ridge axis extends far enough off the coast to block subtropical moisture from the area. This pattern produces heat waves in California. When a weak upper trough pushes into the western portion of the upper ridge, instability can result in a significant outbreak of dry lightning (fig. 3-26).

Alaska Region

The fire season in Alaska extends from May through August but is most active during June and July.

The primary critical fire weather pattern in Alaska is the breakdown of the upper level ridge.

Breakdown of the upper ridge with southwest flow—

This pattern occurs when southeasterly winds push moist, unstable air into the retreating upper level ridge (fig. 3-27). This can bring gusty winds and dry lightning to the interior of Alaska. The June 1998 Carla Lake Fire burned under these conditions caused by wind gusts of 56 km/h and relative humidity of less than 25 percent.

Canada

Critical fire weather pattern research in Canada has primarily concentrated on the relationship between large fire occurrence and the 500 hPa upper level pattern. Newark (1975) researched the 1974 Ontario fire season, one of the worst on record in terms of the number of fires and area burned, and found that a persistent long-wave 500 hPa ridge

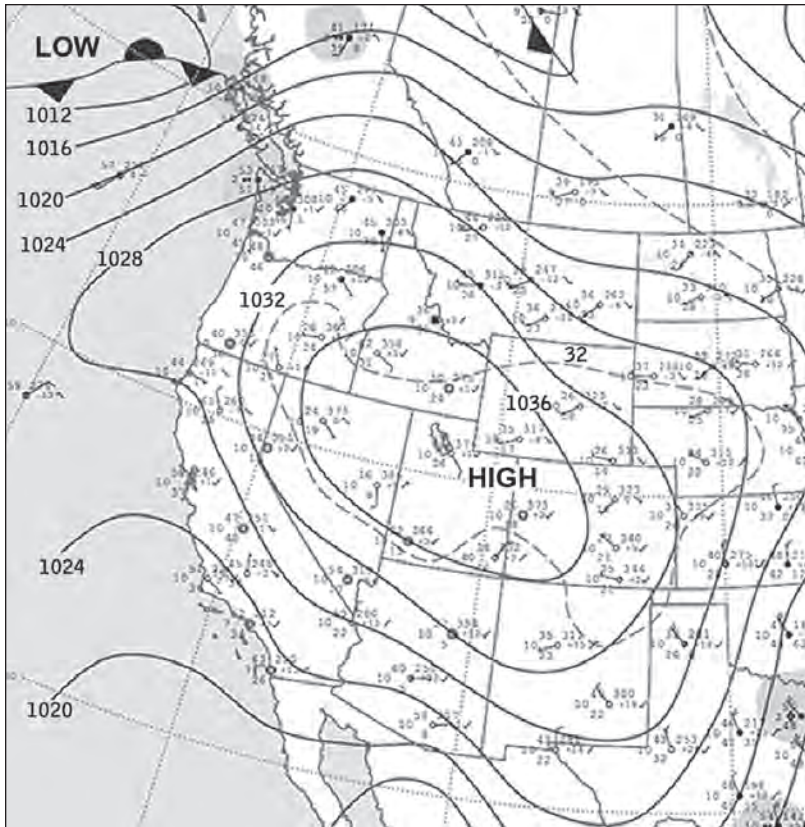

Figure 3-23—1200 Coordinated Universal Time, 22 October 2007, surface pressure map. High centered over Utah with strong pressure gradients over southern California. (National Oceanic and Atmospheric Administration, National Weather Service.)

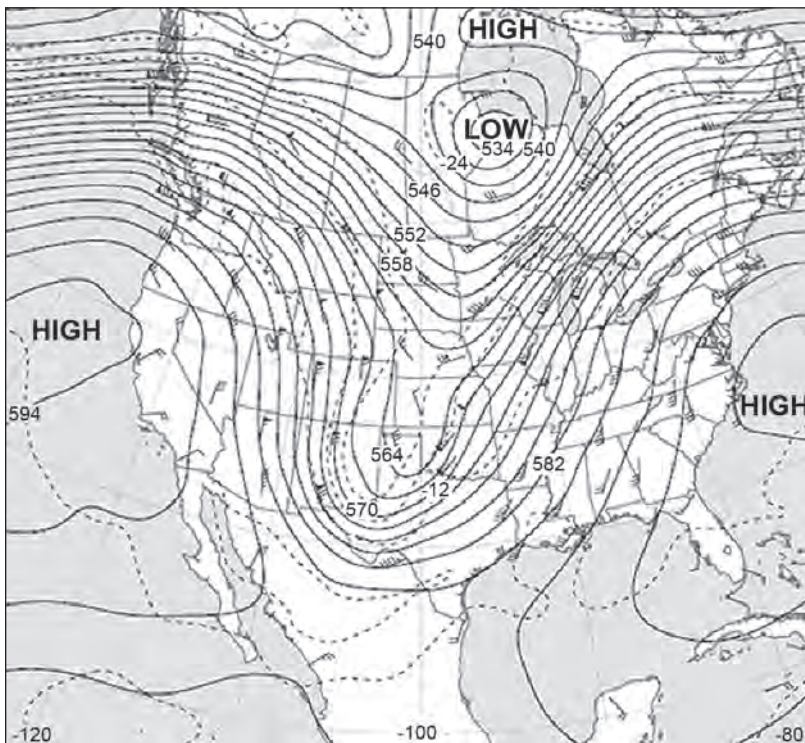

Figure 3-24—1200 Coordinated Universal Time, 22 October 2007, 500 hPa geopotential height map. A strong high was centered off the northern California coast. (National Oceanic and Atmospheric Administration, National Weather Service.)



Figure 3-25—22 October 2007 visible satellite picture showing smoke from numerous southern California wildfires blowing out over the Pacific Ocean. (National Oceanic and Atmospheric Administration, National Weather Service.)

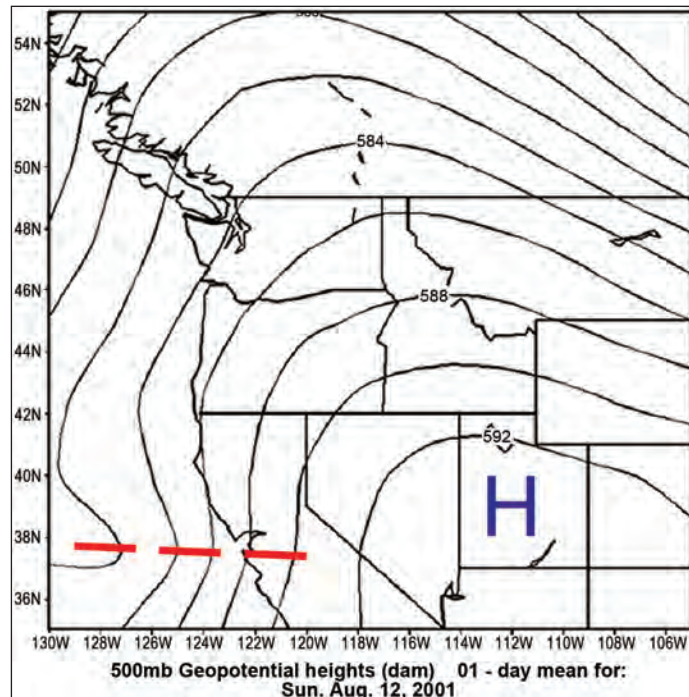

Figure 3-26—Critical California lightning pattern with subtropical 500 hPa ridge over the Great Basin and short-wave trough (red dashed line) moving inland from the Pacific Ocean. (National Oceanic and Atmospheric Administration, National Centers for Environmental Prediction/National Center for Atmospheric Research reanalysis.)

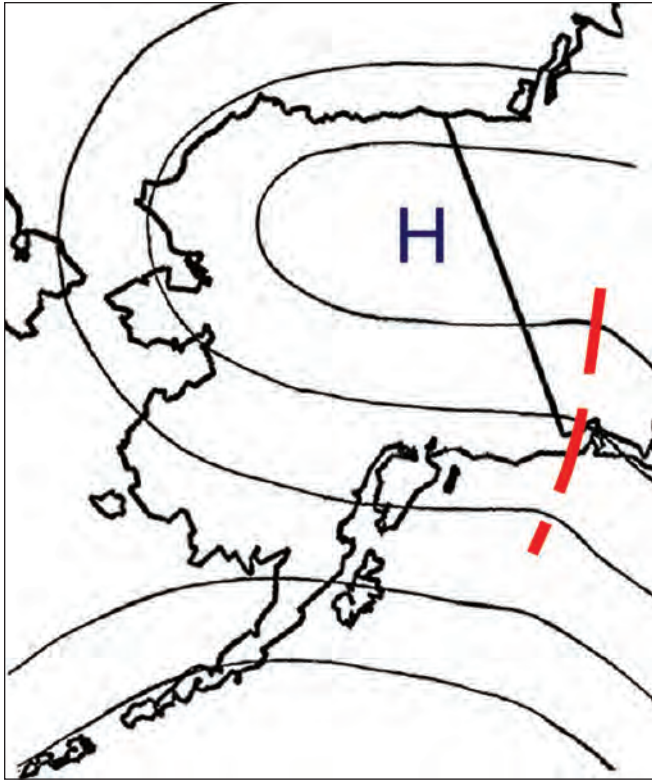

Figure 3-27—Breakdown of the upper ridge (dashed red line) critical fire weather pattern in Alaska. Source: National Weather Service 1993.

was located over northwestern Ontario. This ridge produced an extended period of dry weather from mid-June through early August resulting in extreme fire danger. He also noted that the ridge exhibited orderly oscillating behavior and that the fire danger generally increased during the building of the ridge, decreased during the collapse, and peaked during maximum ridging.

Nimchuk (1983) studied fire weather conditions during the severe 1981 Alberta, Canada, fire season to determine whether there was a relationship between surface and 500 hPa pressure patterns and the occurrence of large wildland fires. He identified the lifetime of an upper level ridge in three distinct stages: establishment, progressive weakening, and final breakdown (fig. 3-4). He concluded that the trigger for extreme fire behavior was the breakdown, rather than the presence of a persistent upper level ridge.

In support of his conclusion, Nimchuk detailed the upper level and surface pressure patterns during the extreme

fire behavior conditions experienced on wildland fires in northern Alberta on August 27, 1981. On that day, winds of 40 to 65 km/h and relative humidity as low as 30 percent caused fire to spread across 376 000 ha of forest land. The 500 hPa pattern (fig. 3-28) showed a strong upper ridge east of the fires in Saskatchewan. An upper low pressure system was centered along the British Columbia coast. Meanwhile, a surface low pressure center (fig. 3-29) was located in northwestern Alberta with a cold front extending southward into northwestern Montana. Both the upper level and surface pattern exhibited strong temperature and pressure gradients across northern and western Alberta resulting in strong southerly surface winds.

Skinner et al. (1999) examined 500 hPa pressure patterns over North America to see if there was a correlation between anomalous height values and wildland fire severity in Canada. Their results showed statistically significant correlations between regional total area burned and clusters of anomalous 500 hPa geopotential height values over and immediately upstream of the affected region. The high burned area years coincided with positive 500 hPa height anomalies while the low burned area years coincided with negative height anomalies.

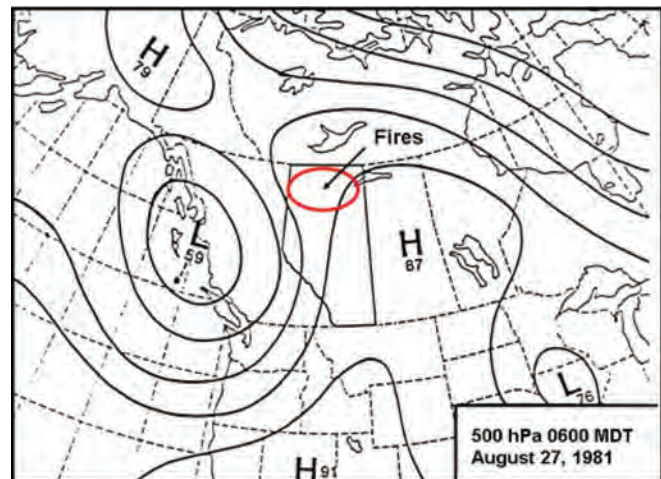

Figure 3-28—0600 Mountain Daylight Time, 27 August 1981, 500 hPa geopotential height map showing a strong ridge over the Canadian Prairie Provinces and a low pressure system along the British Columbia coast. Large northern Alberta wildland fires were burning within a transition zone between the ridge and low pressure system, a pattern known as the breakdown of the upper level ridge. Source: Nimchuk 1983.

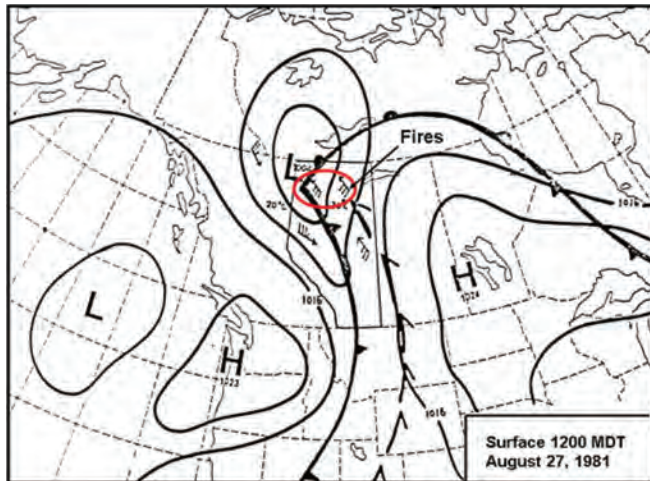

Figure 3-29—1200 Mountain Daylight Time, 27 August 1981, surface pressure map showing high pressure over eastern Saskatchewan and Manitoba and a low pressure center and cold front in Alberta. The large wildland fire in northern Alberta exhibited extreme fire behavior prior to the passage of the cold front. Source: Nimchuk 1983.

In a subsequent study, Skinner et al. (2002) determined that large Canadian wildland fires were associated with strong meridional flow at the 500 hPa geopotential height level rather than zonal, or weak westerly windflow. This substantiates the upper level patterns that Nimchuk (1983) identified during the severe 1981 Alberta fire season.

In general, Canadian critical fire weather patterns are very similar to those experienced in the United States. The Hudson Bay and Northwest Canadian high pressure systems, containing modified arctic air and very low relative humidity, are the primary critical fire weather pattern in the eastern Canadian provinces, such as Ontario and Quebec. Critical fire weather and extreme fire behavior can occur on the periphery of these high pressure systems, especially prior to, during, and after the passage of dry cold fronts. The east slopes of the Rocky Mountains in Alberta are also susceptible to Chinook winds. Timber fires in the Alberta Rocky Mountains typically require an extended drought period, usually from late June into late August and September, followed by a Chinook strong wind and low relative humidity event. Large grass/brush fires exhibiting extreme fire behavior because of Chinook events are possible throughout the winter months of November through March if snow-free conditions exist. On November 27, 2011,

five homes were lost in the Palliser triangle area in southern Alberta to a prairie grass/brush fire during a Chinook event.¹ Foehn-type winds also affect the British Columbia coastal regions and Vancouver Island through a similar mechanism as the east winds in Washington and Oregon (strong surface ridge building rapidly from the north over the British Columbia interior, particularly in fall). This situation is often referred to as an easterly outflow event.

Australia

Fire season extends from June to October in northern Australia (winter months) and November through April (late spring through early fall) in southern Australia. During periods of drought, the threat of bushfires exhibiting extreme fire behavior significantly increases. Outbreaks of historical large bushfires have burned hundreds of thousands of hectares, thousands of homes, and caused many fatalities.

Long (2006) studied fire seasons in the state of Victoria from 1970 to 1999 to determine the frequency of extreme fire weather days and the synoptic weather patterns associated with extreme days. The author found a high percentage of extreme fire weather days occurred when there was a northwest to northerly windflow over Victoria advecting hot, dry air from the Australian interior. Winds from this direction are associated with surface pressure patterns ahead of cold fronts. In the Northern Hemisphere prefrontal winds blow from the south or southwest, but in the Southern Hemisphere these winds blow from the northwest or north. Long also evaluated the Haines Index and found that it correlated well with extreme fire weather days, but at a higher frequency.

The February 16, 1983, Ash Wednesday bushfires in Victoria were the most destructive to that date, taking the lives of 75 people and burning over 335 000 ha. Mills (2005) researched surface and 500 hPa patterns during the fire event and found that the depth of the cool air behind the surface cold front was a critical factor in the severity of the fires. His analysis of 40 years of data indicated the temperature gradient at 850 hPa on Ash Wednesday was the third strongest experienced in any February to date, and the

¹ Nimchuk, N. 2012. Critical fire weather patterns—a few comments. NickNimchuk@gov.ab.ca (7 February 2012?)

10th strongest during any summer month. The strong temperature gradient likely resulted in stronger surface winds that significantly increased the ROS and severity of the fires.

The surface and upper air weather charts Mills examined were indicative of the breakdown of the upper ridge critical fire pattern. The 500 hPa pattern on February 16, 1983 (fig. 3-30), showed a strong upper level high pressure area centered over the Australian interior with a ridge extending across southeastern Australia. At the same time, an upper level trough over the Southern Ocean was moving eastward across southern Australia, pushing the upper ridge farther off the southeastern Australian coastline. Meanwhile, the surface pressure pattern (fig. 3-31) showed a surface high off the eastern Australian coast and a surface low over the Southern Ocean with a cold front extending

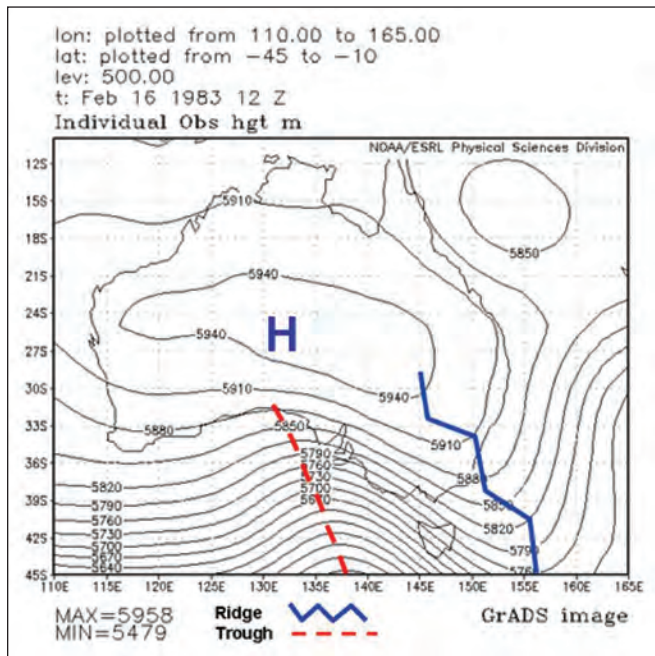

Figure 3-30—1200 Coordinated Universal Time, 16 February 1983, 500 hPa geopotential height map showing a large upper high over the Australian interior with a ridge off the southeastern coast. A well- defined upper trough, over the Southern Ocean, was moving eastward toward New South Wales and Victoria. (National Oceanic and Atmospheric Administration, National Centers for Environmental Prediction/National Center for Atmospheric Research reanalysis.)

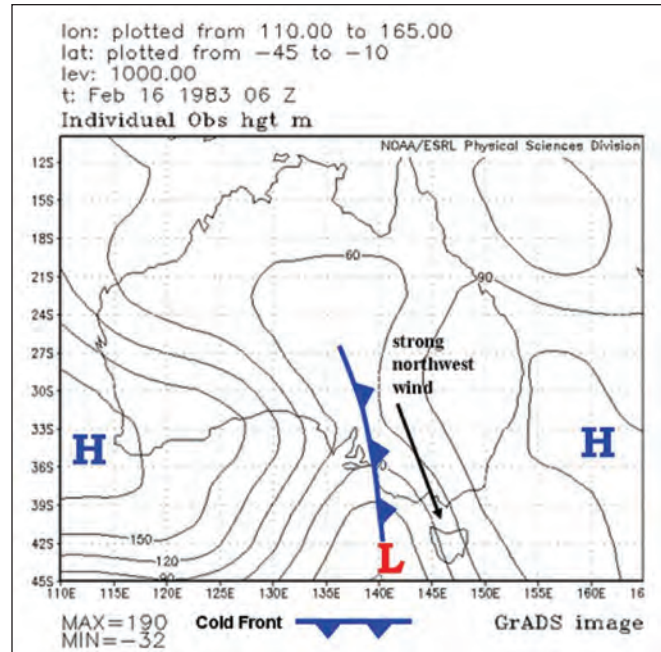

Figure 3-31—0600 Coordinated Universal Time, 16 February 1983, surface pressure map showing high pressure off the eastern Australian coast and a cold front moving eastward across New South Wales toward Victoria. Strong, dry northwesterly winds in advance of the cold front. (National Oceanic and Atmospheric Administration, National Centers for Environmental Prediction/ National Center for Atmospheric Research reanalysis.)

northward into southern Australia. This cold front was moving eastward and would eventually move across Victoria (southeastern Australia) during the day. Between the surface high and the cold front a strong pressure gradient developed, which produced strong northwesterly prefrontal winds across Victoria. These northwesterly winds also brought hot, dry air from the interior of Australia across southeastern Australia. Strong surface wind, very low relative humidity and long-term drought created conditions that resulted in extreme fire behavior on bushfires across Victoria on February 16, 1983.

Models and Predictive Tools

The Predictive Services Program is national in scope. It supports the wildland fire community and others with information and decision-support products. The program encompasses meteorologists and intelligence coordinators at each geographic area coordination center (GACC) and

the National Interagency Coordination Center (NICC). Fire behavior or long-term analysts are detailed to GACCs during the fire season.

The following is a list of products produced by Predictive Services units that are useful in determining areas of greatest concern in relation to large fire potential and the possibility of extreme fire behavior.

The National Wildland Significant Fire Potential Outlook

This product is prepared by NICC on the first business day of each month. The report consists of national maps and associated text that depict areas of below normal, normal, and above normal significant fire potential.

GACC 7-Day Significant Fire Potential

This GACC product is produced daily during the primary fire season under the direction of a qualified fire weather meteorologist. The report contains projected fire weather, fuel dryness, fire danger, fire potential, and resource status information for the next 7-day period. A short discussion accompanies the report detailing weather of concern through the period.

Fuel and Fire Behavior Advisories

These advisories are issued to inform fire managers and firefighters of safety concerns owing to existing or predicted fuel and fire behavior conditions.

Other GACC Products and Services

The GACC Predictive Services units provide a wide variety of products and services in support of wildland fire operations. These include weather/intelligence briefings, situation reports, and resource summaries.

The National Weather Service (NWS) provides fire weather products and services in support of fire management decisions. Some of the best tools in assessing the potential for critical fire weather situations are the Fire Weather Watch and Red Flag Warning program, and Spot Weather Forecasts.

Fire Weather Watches and Red Flag Warnings

Fire Weather Watches and Red Flag Warnings are issued when the combination of dry fuels and weather conditions indicate the possibility of extreme fire danger or fire behavior. These conditions alert land management agencies to the potential for widespread new ignitions that could overwhelm initial attack activities, or conditions that could cause control problems on existing fires, etc. Any of these outcomes could pose a threat to life and property. Fire Weather Watches are issued when there is a high potential for the development of a Red Flag Event. Red Flag Warnings are used to warn of an impending, or occurring Red Flag Event. Their issuance denotes a high degree of confidence that weather and fuel conditions consistent with local Red Flag Event criteria will occur in 24 hours or less.

Spot Weather Forecasts/Digital Web Services

A spot forecast is a site-specific 24- to 36-h forecast issued to fit time, topography, and weather of a specific location. The spot forecast can be requested for wildfires, prescribed burns, spray projects, and other special projects. Other products available include FARSITE data streams and point forecast matrix forecasts from the National Digital Forecast Database. The NWS issues thousands of spot forecasts per year, and there is extensive use of digital Web services in diagnosing fire risks resulting from critical fire weather patterns.

The Storm Prediction Center's (SPC) Fire Weather program issues a daily national fire weather guidance product for use by the NWS, as well as other federal, state, and local government agencies. The product is intended to delineate areas of the contiguous United States where preexisting fuel conditions, combined with forecast weather conditions during the next 8 days, may result in a significant threat of wildfires.

There are three types of Fire Weather Outlook areas:

- Critical Fire Weather Area for wind and relative humidity.
- Extremely Critical Fire Weather Area for extreme conditions of wind and relative humidity.
- Critical Fire Weather Area for dry thunderstorms.

The SPC Fire Weather Outlook comprises a day 1 and a day 2 forecast, in addition to a day 3 through 8 forecast.

Summary/Knowledge Gaps

Fire weather research has been ongoing for nearly a century, and many advances have been made during that time concerning weather's effect on wildland fire behavior. Wind and relative humidity have been effectively incorporated into the fire behavior models. However, the effect of atmospheric stability on fire behavior is not modeled and remains subjective at best. More research is needed, beyond the Haines Index, to quantify the effects of atmospheric stability on fire behavior.

The concept of critical fire weather patterns has been in existence for 50 years. It has been successfully applied to fire case studies, but rarely has it been used in conjunction with weather forecast models to predict periods when large fires or extreme fire behavior are likely to occur.

Future research into the climatology of critical fire weather patterns would be helpful in determining the frequency, duration, and strength of these events during a typical fire season. Because there are large variances in fire season severity, research is also needed to determine whether there are relationships among the occurrence of critical fire weather patterns, sea surface temperature anomalies, and atmospheric teleconnection indices. Sea surface temperature anomalies include El Niño-Southern Oscillation, the Pacific Decadal Oscillation, and the Atlantic Multidecadal Oscillation, for example. Atmospheric teleconnection indices include the Pacific North American Index, the East Pacific/North Pacific Oscillation, North Atlantic Oscillation, the Arctic Oscillation, and others. Research into the strength, or dynamics, of these critical fire weather patterns could be accomplished by studying the temperature and moisture gradients (horizontal and vertical) associated with these systems. Synoptic-scale temperature and moisture gradients significantly affect the surface wind, relative humidity, and atmospheric stability on wildland fires, and ultimately the observed fire behavior. Research concerning the effects of surface thermal troughs on fire behavior also need to be better defined.

Literature Cited

- Anderson, H.E. 1968.** Sundance Fire: an analysis of fire phenomena. Res. Pap. INT-56. Ogden, UT: U.S. Department of Agriculture, Forest Service, Intermountain Forest and Range Experiment Station. 37 p.
- Beals, E.A. 1914.** The value of weather forecasts in the problem of protecting forests from fire. *Monthly Weather Review*. 42(2): 111–119.
- Beals, E.A. 1916.** Droughts and hot weather. *Monthly Weather Review*. 44: 135–138.
- Brotak, E.A. 1979.** The Bass River Fire: weather conditions associated with a fatal fire. *Fire Management Notes*. 40(1): 10–13.
- Brotak, E.A. 1992-1993.** Low-level weather conditions preceding major wildfires. *Fire Management Notes*. 53–54: 23–26.
- Brotak, E.A.; Reifsnyder W.E. 1977a.** An investigation of the synoptic situations associated with major wildland fires. *Journal of Applied Meteorology*. 16(9): 867–870.
- Brotak, E.A.; Reifsnyder, W.E. 1977b.** Predicting major wildland fire occurrence. *Fire Management Notes*. 38: 5–8.
- Brown, A.A. 1950.** Warning signs for fire fighters. *Fire Control Notes*. 11(3): 28–29.
- Byram, G.M. 1954.** Atmospheric conditions related to blowup fires. Sta. Pap. 35. Asheville, NC: U.S. Department of Agriculture, Forest Service, Southeastern Forest Experiment Station. 34 p.
- Byram, G.M.; Nelson, R.M. 1951.** The possible relation of air turbulence to erratic fire behavior in the Southeast. *Fire Control Notes*. 12(3): 1–8. (Republished in *Fire Management Today*. 63(3): 46–51.)
- Crimmins, M.A. 2005.** Synoptic climatology of extreme fire-weather conditions across the Southwest United States. *International Journal of Climatology*. 26: 1001–1016.

- Crosby, J.S. 1949.** Vertical wind currents and fire behavior. *Fire Control Notes*. 10(2): 12–15.
- Countryman, C.M.; Chandler, C.; Arnold, K. 1956.** Fire behavior: Inaja Fire disaster November 25, 1956. Berkeley, CA: U.S. Forest Service, California Forest and Range Experiment Station Report.
- Dague, C.I. 1930.** Disastrous fire weather of September, 1929. *Monthly Weather Review*. 58: 368–370.
- Dague, C.I. 1934.** The weather of the great Tillamook, Oregon, fire of August 1933. *Monthly Weather Review*. 62(7): 227–231.
- Davis, R.T. 1969.** Atmospheric stability forecast and fire control. *Fire Control Notes*. 30(3): 3–4, 15.
- Gibson, C.V. 1996.** Break-down of the western U.S. upper-level ridge: a critical fire weather pattern. 22nd conference on agricultural and forest meteorology. Boston, MA: American Meteorological Society: 261–262.
- Gisborne, H.T. 1927.** Meteorological factors in the Quartz Creek forest fire. *Monthly Weather Review*. 55(2): 56–60.
- Goens, D.W.; Andrews, P.L. 1998.** Weather and fire behavior factors related to the 1990 Dude Fire near Payson, Arizona. In: *Proceedings: 2nd symposium on fire and forest meteorology*. Boston, MA: American Meteorological Society. 153–158.
- Haines, D.A. 1988.** A lower atmospheric severity index for wildland fires. *National Weather Digest*. 13: 23–27.
- Haines, D.A.; Sando R.W. 1969.** Climatic conditions preceding historically great fires in the North Central Region. Res. Pap. NC-34. St. Paul, MN: U.S. Department of Agriculture, Forest Service, North Central Forest and Range Experiment Station. 23 p.
- Hoenisch, R. 2009.** January 31st 2009 off-season grassland wildfire. Tech. Attachment. LiteTA-lite. 09-11. Salt Lake City, UT: National Oceanic and Atmospheric Administration, National Weather Service, Western Region.
- Hofmann, J.V. 1923.** Meteorological factors and forest fires. *Monthly Weather Review*. 51(11): 569.
- Hughs, M.; Hall A. 2009.** Local and synoptic mechanisms causing southern California Santa Ana winds. *Climate Dynamics*. SpringerLink. doi 10.1007/s00382-009-0650-4.
- Hull, M.K.; O’Dell C.A.; Schroeder, M.J. 1966.** Critical fire weather patterns: their frequency and levels of fire danger. Berkeley, CA: U.S. Department of Agriculture, Forest Service, Pacific Southwest Forest and Range Experiment Station. 40 p.
- Jemison, G.M. 1932.** Meteorological conditions affecting the Freeman Lake (Idaho) Fire. *Monthly Weather Review*. 60(1): 1–2.
- Joy, G.C. 1923.** Forest fire weather in western Washington. *Monthly Weather Review*. 51(11): 564–566.
- Kauffman, E. 1937.** Death in Blackwater Canyon. *American Forests*. 1937(November): 534–559.
- Krumm, W.R. 1954.** An explanation of meteorological conditions which probably caused unexpected behavior of the Rattlesnake Fire, Mendocino National Forest, July 9, 1953. Unpublished report. On file with: National Weather Service, 1945 Beechcraft Ave., Pocatello, ID 83204.
- Long, M. 2006.** A climatology of extreme fire weather days in Victoria. *Australian Meteorological Magazine*. 55(1): 3–18.
- McCarthy, E.F. 1923.** Forest fire weather in the southern Appalachians. *Monthly Weather Review*. 51(4): 182–185.
- McCarthy, E.F. 1924.** Forest fires and storm movement. *Monthly Weather Review*. 52: 257–259.
- Miline, R. 2006.** Critical lightning induced wildfire patterns for the Western Great Basin. Tech. Attachment. LiteTA-lite 06-13. National Oceanic and Atmospheric Administration, National Weather Service, Western Region. <http://www.frames.gov/rcs/11000/11673.html>. (November 18, 2013).
- Mills, G.A. 2005.** A re-examination of the synoptic and mesoscale meteorology of Ash Wednesday 1983. *Australian Meteorology Magazine*. 54: 35–55.

- Munns, E.N. 1921.** Evaporation and forest fires. *Monthly Weather Review*. 49(3): 140–152.
- National Weather Service. 1993.** Critical fire weather patterns of the United States. **Fire Weather Training Report**. http://www.nwccweb.us/content/products/fwxc/publications/CRITICAL_FWX_PATTERNS_US.pdf. (May 13, 2011).
- Newark, M.J. 1975.** The relationship between forest fire occurrence and 500 mb longwave ridging. *Atmosphere*. 13(1): 26–33.
- Nimchuk, N. 1983.** Wildfire behavior associated with upper ridge breakdown. Report No. T/50. Edmonton, AB: Alberta Energy and Natural Resources, Forest Service. 45 p.
- Ortel, A.G. 1964.** Weather types associated with critical fire weather conditions in Northern and Central California. Unpublished report. On file with: U.S. Department of Agriculture, Forest Service Pacific Wildland Fire Sciences Laboratory, 400 N 34th St., Suite 201, Seattle, WA 98103.
- Rorig, M.L.; Ferguson, S.A. 1999.** Characteristics of lightning and wildland fire ignition in the Pacific Northwest. *Journal of Applied Meteorology*. 38(11): 1565–1575.
- Saltenberger, J.; Barker, T. 1993.** Weather related unusual fire behavior in the Awbrey Hall Fire. *National Weather Digest*. 18(2): 20–29.
- Schaefer, V.J. 1957.** The relationship of jet streams to forest wildfires. *Journal of Forestry*. 55: 419–425.
- Schroeder, M.J. 1950.** The Hudson Bay high and the spring fire season in the Lake States. *Fire Control Notes*. 11(1): 1–8. (Also in *Bulletin of the American Meteorological Society*. (1974). 31(4): 111–118 as same title, slightly different text.)
- Schroeder, M.J.; Buck, C.C. 1970.** Fire weather. In: *Fire climate regions*. Agric. Handb. 360. Washington, DC: U.S. Department of Agriculture, Forest Service: 196–220. Chapter 12.
- Schroeder, M.J.; Glovinsky, M.; Hendricks, V.F.; Hood, F.C.; Hull, M.K.; Jacobson, H.L.; Kirkpatrick, R.; Krueger, D.W.; Mallory, L.P.; Oertel, A.G.; Reese, R.H.; Sergius, L.A.; Syverson, C.E. 1964.** Synoptic weather types associated with critical fire weather. Berkeley, CA: U.S. Department of Agriculture, Forest Service, Pacific Southwest Forest and Range Experiment Station. 492 p.
- Show, S.B. 1931.** Meteorology and the forest fire problem. *Monthly Weather Review*. 59: 432–433.
- Simard, A.J.; Haines, D.A.; Blink, R.W.; Frost, J.S. 1983.** The Mack Lake Fire. Gen. Tech. Rep. NC-83. St. Paul, MN: U.S. Department of Agriculture, Forest Service, North Central Forest Experiment Station. 36 p.
- Skinner, W.R.; Flannigan, M.D.; Stocks, B.J.; Martell, D.L.; Wotton, B.M.; Todd, J.B.; Mason, J.A.; Logan, K.A.; Bosch, E.M. 2002.** A 500 Mb synoptic wildland fire climatology from large Canadian forest fires, 1959–1996. *Theoretical and Applied Climatology*. 71: 157–169.
- Skinner, W.R.; Stocks, B.J.; Martelli, D.L.; Bonsal, B.; Shabbar, A. 1999.** The association between circulation anomalies in the mid-troposphere and area burned by wildland fire in Canada. *Theoretical and Applied Climatology*. 63: 89–105.
- Stickel, P.W. 1928.** Forest-fire weather in Central Massachusetts. *Monthly Weather Review*. 56(4): 134–136.
- Syverson, C.E. 1962.** Prediction of the crisis period and the use of Red Flag Forecasts. Unpublished report. On file with: U.S. Department of Agriculture, Forest Service, Pacific Wildland Fire Sciences Laboratory, 400 N 34th St., Suite 201, Seattle, WA 98103.
- Syverson, C.E. 1963.** Fire weather synoptic types of the Northern Intermountain, Northern Rockies and the Northwestern Plains Regions. Unpublished report. On file with: U.S. Department of Agriculture, Forest Service, Pacific Wildland Fire Sciences Laboratory, 400 N 34th St., Suite 201, Seattle, WA 98103.

Syverson, C.E. 1964. The meridional ridge–Pacific high, and fire weather of Northern Intermountain, Northern Rockies, and the Northern Plains. Unpublished report. On file with: U.S. Department of Agriculture, Forest Service, Pacific Wildland Fire Sciences Laboratory, Seattle, WA 98103.

U.S. Department of Agriculture; U.S. Department of the Interior; U.S. Department of Commerce [USDA, USDI, and USDC]. 1994. Report of the South Canyon Fire Accident Investigation Team (SCAIT). U.S. GPO 1994-573-183 / 84023 Region No. 8. Washington, DC: U.S. Government Printing Office. 243 p.

Weidman, R.H. 1923. Relation of weather forecasts to the prediction of dangerous forest fire conditions. *Monthly Weather Review*. 51(11): 563–564.

Werth, P.A.; Ochoa, R. 1990. The Haines Index and Idaho fire growth. *Fire Management Notes*. 51(4): 9–13.

Werth, P.A.; Ochoa, R. 1993. The evaluation of Idaho wildfire growth using the Haines Index. *Weather and Forecasting*. 8(2): 223–234.

Williams, E.B.; Smith, A.D. 1962. Case history of the Brasstown Fire. Unpublished report. On file with: National Fire Behavior School, San Dimas, CA 91773.

Chapter 4: The Role of Fuels in Extreme Fire Behavior

Russell Parsons¹, W. Matt Jolly², Chad Hoffman³, and Roger Ottmar⁴

Introduction

Fuels are central to the problem of extreme fire behavior. While it is possible to have fires without the influence of topography and under diverse weather conditions, it is impossible to have fire without fuels. Numerous instances of fatalities or close calls have occurred in deceptively light fuels where extreme fire behavior might not have been expected. Virtually all of the critical fire management issues facing land managers in years to come are fuels related. Changes in fuels because of climate change, disturbances such as insect pathogen outbreaks, windthrow, and invasive species have already changed fire management and will only continue to do so. Furthermore, of the three components of the fire behavior triangle (fig. 4-1), fuels are the only component that we have some capacity to manipulate through management actions. Fuels are also an area of fire science where advances in knowledge and technology offer new hopes and possibilities. Looking forward, advances in our ability to quantify and map fuels, using new tools such as laser imaging and high-resolution imagery will help develop fuels maps with more detail than was available before. Additionally, new physics-based fire models are emerging that will enable us to examine and improve our understanding of the sensitivities of fire behavior to fuels with greater detail than was possible before. For these reasons, there is a compelling need to characterize the role of fuels in extreme fire behavior.

This chapter summarizes the role of wildland fuels in extreme fire behavior with a “big picture” perspective that captures the salient properties of fuels, both at fine scales

and across landscapes. We hope to inform readers of the current state of the science and to highlight knowledge gaps, with the idea of complementing, rather than duplicating, material presented elsewhere in this review.

Key Aspects of Fuels: the Fuels Pentagon

Fuels are probably the most complex component in the fire environment triangle, yet are in many ways the least understood. While commonly conceptualized as being homogenous (dead) material, fuels are actually vegetation and span the full spectrum from live and vigorously growing vegetation to dead and decomposed material. Even simple fuel beds such as grasslands can have multiple types of fuels in multiple states or conditions. Under the right circumstances, all fuels are potentially available for combustion, but more often, different types of fuels will interact with fire in different ways.

Five general characteristics influence how fuel particles will burn: chemistry, quantity, density, geometry, and continuity. We highlight these characteristics in the concept of the fuels pentagon in figure 4-2. The term geometry is broadly used here to include both the shape and size of

¹ Russel A. Parsons is a research ecologist, U.S. Department of Agriculture, Forest Service, Missoula Fire Sciences Laboratory, 5775 US West Highway 10, Missoula, MT 59808.

² W. Matt Jolly is an ecologist, U.S. Department of Agriculture, Forest Service, Missoula Fire Sciences Laboratory, 5775 US West Highway 10, Missoula, MT 59808.

³ Chad Hoffman is an Instructor, Wildland Fire Program, College of Natural Resources, University of Idaho, Moscow, ID 83844.

⁴ Roger D. Ottmar is a research forester, U.S. Department of Agriculture, Forest Service, Pacific Wildland Fire Sciences Laboratory, 400 N 34th St., Suite 201, Seattle, WA 98103.

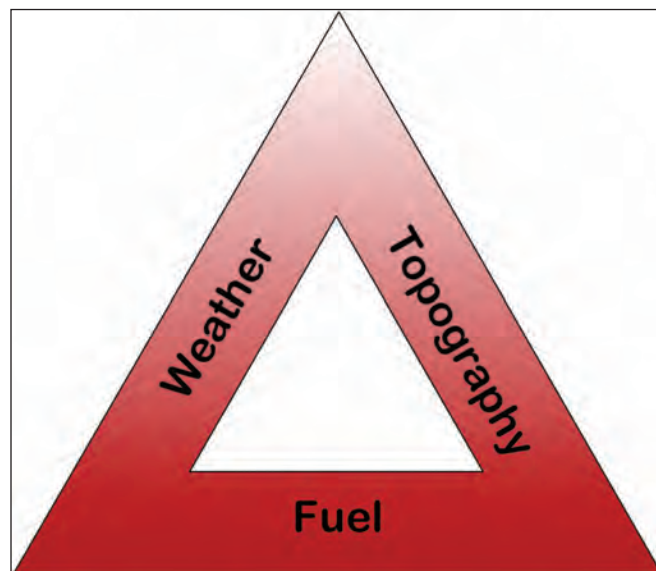

Figure 4-1—The fire behavior triangle.

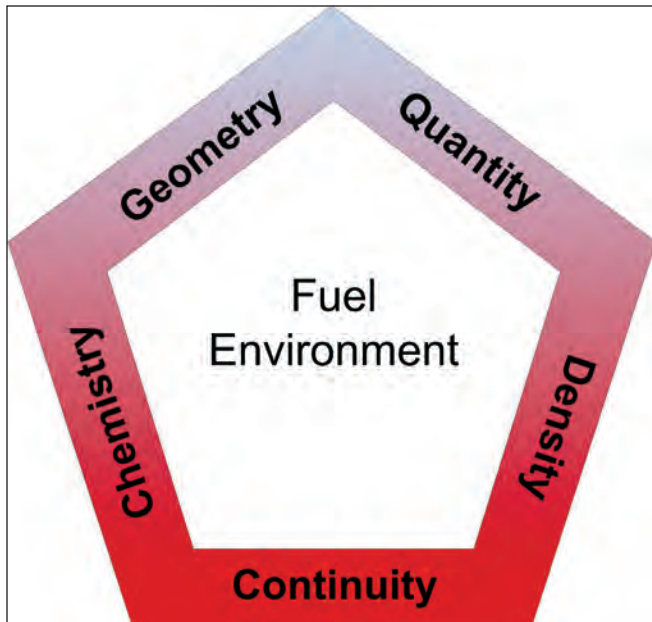

Figure 4-2—The fuels pentagon.

a given fuel particle, and its spatial relationship to other particles. Because we are generally interested in how fire spreads between particles, continuity is included as a key fuels characteristic and relates to the arrangement and distances between particles at various scales. While one characteristic may dominate how fuels burn, all characteristics interact to influence how fuels burn at a given time.

Scaling From Particles to Landscapes

Fires can exist across a wide range of spatial scales, thus it is useful to consider fuels across a series of hierarchical scales, starting with individual particles, such as a leaf or twig. This concept of scales more precisely identifies what aspects of fuels are influencing fire behavior, and by extension, what might contribute to extreme fire behavior. For example, an individual shrub or tree can be considered as a collection of particles. Under most conditions, only a subset of that collection (typically the drier, smaller diameter particles) will burn. The collection of shrubs in an area constitutes the shrub component within the larger fuel bed, which may include several vegetation components (e.g., understory and overstory trees, and litter). The diversity of fuels within most wildland fuel beds makes them difficult to

classify or describe. One strategy to address this complexity is to describe fuels as a series of components, each with its own properties, such as is done in the Fuel Characteristic Classification System (FCCS) (Ottmar et al. 2007, Riccardi et al. 2007). The FCCS considers fuel beds as being composed of canopy, shrubs, nonwoody vegetation, woody dead material, and other basic components (fig. 4-3). Scaling up, a landscape can be viewed as a collection of fuel beds with different properties.

Below, we describe the five fuels characteristics that compose the fuels pentagon and how each contributes to extreme fire behavior, with an emphasis on fundamental fuels properties that are measurable at the scales of individual particles or small collections of particles. In subsequent sections, we address how these fine-scale fuels characteristics are influenced by the landscape context.

Chemistry

Fuels particles are composed of five broad chemical categories: water, carbohydrates, fats, proteins, and ash (mineral) content. In downed, dead sound woody fuels, water can compose only a small fraction of the total mass of the fuels, while in dead, rotten woody fuels' and live fuels, water can make up 50 percent or more of the fuels total mass. The remainder of the fuel's total mass is distributed disproportionately across the remaining four categories. A fuel's fractional allocation to different categories of chemical compounds varies substantially depending on whether the fuel is alive or dead and for different parts of the fuel such as leaves or branches. We will detail the roles of each of the compounds on wildland fuels' heat content and flammability with the exception of proteins, which are not likely a large contributor to combustion.

Fuel water or moisture content—

Fuel moisture content has long been considered a factor in driving fire behavior (Fons 1946, Hawley 1926, Richards 1940). The specific heat of water is approximately 4000 J/(kg °C), over four times that of any other chemical component of wildland fuels. This suggests that a lot of energy goes into raising the water to boiling temperature that could otherwise be used to raise the fuel to ignition temperature and

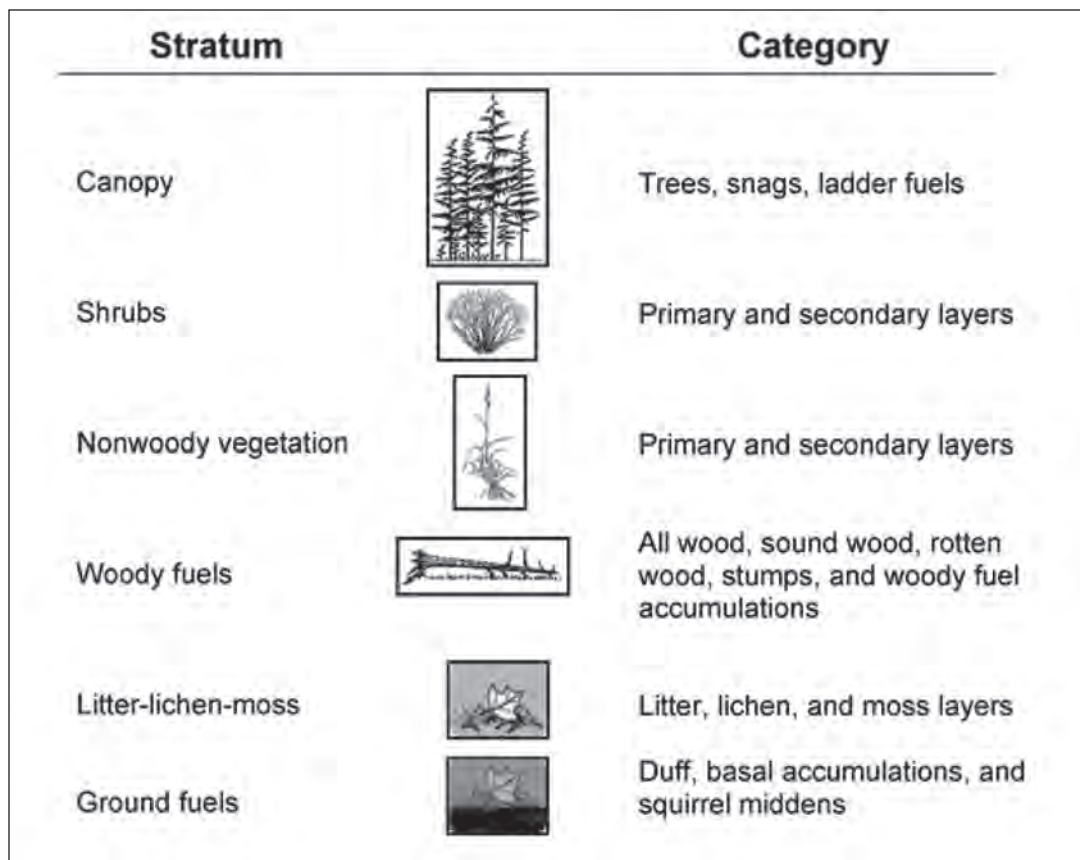

Figure 4-3—Horizontal stratification of an Fuels Characteristic Classification System fuel bed by strata and categories for improved fire behavior prediction.

create the gases that support flames. Fuels are ignited by raising their temperature to a point where sufficient volatile compounds are produced and are ignited either spontaneously or through a pilot heat source. When fuels are heated, some of the moisture is evaporated and pyrolysis is taking place. Conventional wisdom suggests all the moisture must be removed from a fuel particle before significant pyrolysis can occur (Rothermel 1972), but both theoretical (Catchpole and Catchpole 1991) and experimental (Pickett et al. 2010) results suggest that not all water in a fuel particle must be removed prior to ignition. However, many studies have shown that it takes longer to ignite a fuel particle with a higher moisture content (Dimitrakopoulos and Papaioannou 2001, Pellizzar et al. 2007, Xanthopolous and Wakimoto 1993) and thus moisture content must account for at least a portion of the ignitability of fuels.

Carbohydrates—

Carbohydrates make up a large percentage of wildland fuels and can generally be classified as either structural or nonstructural (fiber and nonfiber). Generally, live fuels are equally split between fiber and nonfiber-based compounds, while dead fuels are mostly composed of only fiber-based compounds such as holocelluloses and lignin. Structural carbohydrates give fuels form, strength, and stability and the nonstructural carbohydrates serve as energy reserves in living plants. These carbon-based compounds provide the primary substrates for the gases that contribute to flaming combustion. Fuel combustion studies have primarily focused on structural compounds because it has been assumed that fuels are mostly composed of those compounds (Philpot 1970, Shafizadeh 1968). While that may be true for commercial lumber, it is not true for wildland fuels.

Fats—

Fat-based compounds make up 10 percent or more of a fuel's dry mass. These compounds are generally composed of waxes, oils, resins, and isoprenes. In literature, this group of compounds is often referred to as crude fat, ether extractives, or simply extractive content. Highly flammable leaves are often found to contain large amounts of crude fats; eucalyptus leaves' crude fat content is nearly 20 percent of their dry mass (Mutch 1970). Fats are an important fuels component because they can potentially release twice as much heat as other leaf compounds (Merrill and Watt 1973). Thus small changes in fat can cause large changes in a fuel's flammability. Much attention has been given to changes in a fuel's flammability in relation to changes in extractive content. However, no studies have shown a conclusive link between changes in isoprenes and changes in flammability. Owens et al. (1998) suggested that changes in the terpene limonene can increase flammability of Ashe juniper (*Juniperus ashei*) by as much as 30 percent while the presence of other terpenes decreased its flammability. In contrast, Alessio et al. (2008) found only a few weak correlations between terpene concentrations and flammability. Burgan and Sussot (1991) found that the amount of volatile compounds present was dependent on leaf age and that foliar flammability might therefore differ between old and new foliage. It is likely that the interactive nature of high moisture contents and high terpenoid concentrations may combine to limit their ability to influence combustion (De Lillis et al. 2009).

Mineral (ash) content—

Mineral, or ash, content is a measure of the amount of fuel that is composed of unburnable compounds. It is generally quantified as the ash content or ash fraction of a fuel measured as the remaining biomass after complete combustion of a fuels sample. Ash content is sometimes corrected by removing silica from the ash sample because silica is considered to be completely inert to combustion processes (Philpot 1970). The remaining ash, however, can alter fuel combustion by increasing the proportion of charring to flaming combustion. Small changes in ash content induced

large changes in the combustion of wildland fuels; however, it is likely that not all of the ash content is involved in shifting combustion pathways. Ash content can vary greatly between species and is believed to contribute to the flammability of different species or of the same species at different times of the year (Broido and Nelson 1964).

Heat content—

The heat content (heat of combustion) of wildland fuels is a measure of the amount of thermal energy produced during the complete combustion of fuels and is strongly related to the percentage of the fuel composed of carbon (Sussott et al. 1975). Although not highly variable, heat content has been shown to vary among species, especially when the inorganic ash fraction of the samples is removed (Williamson and Agee 2002). Heat contents are usually reported as either high (gross) or low (net) heat content depending on whether or not the measured values have been corrected for the heating of the water vapor during the measurement. Total heat content of a wildland fuel is likely the sum of the individual heat contents of the chemical compounds that make up the fuel, weighted by their respective dry mass percentages. This may be important because compounds such as crude fats have twice the heat content per unit mass of carbohydrates such as cellulose, and thus as these compounds vary from species to species or seasonally within a species, they may influence the apparent fuel heat content.

However, all of these values report the total heat of combustion and not the effective heat of combustion available to preheat adjacent fuels and help a fire spread. The effective heat of combustion is always lower because char has a high heat content but generally remains unburned during a wildland fire (Babrauskas 2006).

Flammability—

Anderson (1970) suggested a standardized method for rating wildland fuel flammability, which is broken into three categories: ignitability, sustainability, and combustibility. Ignitability is measured in terms of the ignition delay time, or time to ignition; sustainability measures how well the fuel can burn when the heat source is removed; and combustibility quantifies the rate of the combustion reaction.

Attempts have been made to use foliar chemistry and moisture content to characterize flammability, but these studies are rarely standardized in a format that would permit their intercomparison.

Most studies focus on fuels ignitability, most likely because it is the easiest to measure. Many studies have shown that ignitability is highly correlated to changes in foliar moisture content (Dimitrakopoulos and Papaioannou 2001, Pellizzaro et al. 2007, Xanthopoulos and Wakimoto 1993), but these studies rarely explain more than half of the ignitability variation, suggesting that there are many unknown drivers that influence flammability. Other studies suggest that a more physical approach is needed to assess flammability or fire hazard and recommend metrics such as the fuel's heat release rate as a way to rank a fuel's flammability (Babrauskas and Peacock 1992). Heat release rate may be more related to combustibility than ignitability and thus both metrics may help to elucidate the true factors that are important to fuel flammability.

So far we have discussed fuels' different chemical components, which influence all fire behavior. This is the first, and perhaps most fundamental leg of the fuels pentagon. In addition to these chemical components, there are four key physical and structural characteristics of fuels, which constitute the other four legs of the fuels pentagon: geometry, mass, density, and continuity. Each of these key aspects can influence fire behavior and each is discussed in more detail below.

Geometry

Surface area-to-volume ratio is a fuel property that describes individual fuel particle geometry and strongly influences flammability, fuel temperature, and moisture dynamics. Surface area-to-volume ratio is often assessed based on measurements of diameter. However, assignment of fuel size classes based on diameter is only valid for fuels that have a cylindrical or rectangular geometric shape (Brown 1971). Where the geometric shape of the fuels particle departs from either a cylindrical or rectangular shape, more advanced measurement methods are required to estimate this parameter. Accuracy of surface area-to-volume ratios greatly depends on the degree of departure

from the assumed geometry (Brown 1971). However, other methods based on water immersion do not need to assume a geometric shape and have shown good agreement with standard measurements (Fernandes and Rego 1998). The size of fuel particles influences the amount of heat required to ignite and combust the particle. Smaller particles require less heat exposure to ignite and combust compared to larger fuel particles.

Surface area-to-volume ratio also forms the basis for the concept of timelag size classes (Fosberg 1970). The concept of timelag size classes is based on the amount of time required for dead fuel to lose approximately 63 percent of the difference in between its initial moisture content and the equilibrium moisture content in the atmosphere. Four timelag classes are currently used to characterize dead fuels: 0 to 2 h, 2 to 20 h, 20 to 200 h, and >200 h. Class midpoints were then used as the title for each timelag class: 1-h, 10-h, 100-h, 1,000-h. Timelag size classes have been widely used to assist in describing the fuel mass and distribution of fuel sizes within an area. The fuel mass by timelag size classes is used in mathematical predictions of fuel moisture, fire behavior, fire danger ratings, and in descriptions of fuels complexes. In general, fine fuels tend to combust more rapidly and have been associated with several firefighter fatalities and close calls (NWCG 1997).

In addition to information regarding particle size, the distribution of fuel particles, estimates of fuel mass within an area, and the arrangement of fuel are other important variables that influence fire behavior. Fuel arrangement pertains to the packing ratio or compactness of fuel particles as well as the vertical and horizontal continuity of the fuels. In most empirical and semiempirical fire models, fuels are assumed to be homogeneously and continuously arranged; however, in real world situations, this seldom occurs. The effects of heterogeneous arrangements and deviations from continuity on fire behavior are not well understood.

Quantity

The quantity (mass) of fuel available for combustion is a key factor in how fires burn. Fuel quantities are often expressed as a "loading" in terms of mass per unit area, such as tons per acre. Determination of quantity of fuels by size classes

is one of the fundamental assessments conducted in fuels inventory and, in conjunction with fuel moisture, meteorological parameters, and topography, helps to determine the availability of fuels to consume, generate fire intensity, and spread the flaming front along the ground or in the crowns of trees and shrubs.

There are several definitions commonly used in the assessment and communication of fuel mass. The three most common are total fuel mass, potential fuel mass, and available fuel mass. Total fuel mass, or total biomass, is often considered the entire amount of combustible material present in an area. Potential fuel mass is the amount of the entire fuel mass that could burn in the hottest possible fire. Available fuel mass is the amount of the total fuel mass that will be consumed for a particular situation. In some cases, these three values may be very similar; however, in most forested fuels complexes, these values will differ greatly. Differences among the three fuel mass definitions arise from weather conditions, the distribution of fuel size classes, and other properties of the fuels complex. For example, in a moist temperate rain forest of the Pacific Northwest, total fuel mass can be in the hundreds of Mg/ha; of this, however, the potential fuel mass will typically be considerably less, as much of the larger diameter material, while flammable, is difficult to ignite. The available fuel mass is often a much smaller quantity because of the generally moist conditions. In each case, the fuel masses include a combination of living and dead fuels. In many cases, the proportion or mass of fuels by categories (i.e., living vs. dead or timelag size classes) are reported in addition to one of the above.

Live surface fuels are often further grouped into herbaceous and woody fuel components, while dead surface fuels are often grouped into timelag size classes, and canopy fuels are often grouped into foliage and woody timelag size classes. The result of such groupings allows for total, available, and potential fuel masses to be quantified and the distribution of fuels based on size classes to be described. Fuel masses by size classes or one of the above mentioned groups are often required as inputs for mathematical fire models, such as Rothermel (1972) and for fire behavior

modeling systems such as BehavePlus (Andrews et al. 2003), FCCS (Ottmar et al. 2007), Nexus (Scott 1999, Scott and Reinhardt 2001), First Order Fire Effects (Reinhardt et al. 1997), and Consume (Ottmar et al. 2005) to predict fire behavior and effects.

Density

The compactness of fuel particles in a fuel bed influences several processes related to combustion, including heat transfer and oxygen diffusion within the fuel bed. The simplest measure of fuel compactness commonly used to describe the canopy fuels complex is bulk density. Bulk density is a measure of the weight of fuel per unit volume, and includes not just the fuel particles but also the space between fuel particles. The concept of bulk density can be applied to either surface or crown fuels. In mathematical fire behavior models, the bulk density is often converted to a packing ratio. Rothermel (1972) defined the packing ratio as the fuel bulk density divided by the particle, or material density (such as a solid block of wood), thus the packing ratio is a dimensionless number. In addition to the actual fuel bed packing ratio, a theoretical optimum packing ratio can be calculated from the surface area-to-volume ratio of the fuel particles within the fuel bed. The quotient of the packing ratio divided by the optimum packing ratio is an important concept within the Rothermel (1972) fire behavior model as this value affects the optimum reaction velocity and the wind adjustment factor term. In terms of crown fuel assessment, density is most commonly represented as canopy bulk density. Canopy bulk density has been incorporated as a primary variable influencing crown fire spread in several fire behavior prediction systems (see chapter 9 of this review) and is commonly included in fuel hazard assessments.

Continuity

Another fuel characteristic with important implications for extreme fire behavior is continuity. Continuity refers to the degree to which fuels are uninterrupted. Continuity cannot be considered at the scale of a single particle but is quite important to how fire burns across collections of particles. At the scale of individual particles, such as surface beds of

leaves or needles, fuels are often considered to be continuous even though gaps between particles exist because the size of the gaps are small compared to typical flame sizes as fires burn through the fuel bed (Finney et al. 2010).

At larger scales, horizontal and vertical fuel continuity is very important to fire spread. Horizontal continuity is primarily related to the spread of a fire across a landscape, while vertical continuity influences vertical fire movement among fuel layers such as surface-to-crown fire transition. One important aspect of continuity is the spatial scale at which we consider this variable.

In mathematical fire behavior models such as Rothermel (Rothermel 1972, 1991) and Van Wagner (Van Wagner 1977), fuel is assumed to be homogenous and no spatial variations are considered. In the Rothermel (1972) fire spread model, the effect of decreased continuity of surface fuels is expressed through alterations to the packing ratio. In terms of canopy fuels, vertical continuity is expressed through the bulk density of the fuel layer. Although often not included in mathematical descriptions of fire spread, a common measure of continuity in the field is estimated percentage or fractional cover.

In terms of surface-to-crown fire transition, continuity is captured through an estimation of the canopy base height. Canopy base height is defined as the lowest height above the ground at which there is sufficient canopy fuel for fire to propagate vertically. This is, however, difficult to directly measure. Several methods have been used to estimate canopy base height, including the height at which a given amount of canopy bulk density exists, the mean crown base height, the lowest crown base height, and a percentile crown base height.

Operational fire behavior models do not explicitly account for spatial variation in vertical and horizontal continuity. However, more recent models have been developed that can allow for both vertical and horizontal continuity to be included (Linn et al. 2002, 2005; Mell et al. 2009; Morvan and Dupuy 2001). Despite difficulties in quantification of spatial continuity and a lack of modeling methodologies able to account for spatial continuity, a lack of horizontal continuity can reduce fire rate of spread, or

completely prevent spread in extreme cases. Conversely, increased horizontal and vertical continuity can increase the potential for fire spread and crown fire initiation (chapter 9).

The disruption or alteration of vertical and canopy fuel continuity has been used to guide fuel management operations and fire suppression operations. The removal of fuels through the construction of fire line in fire operations reduces horizontal fuel continuity with the goal of preventing further horizontal spread of the fire. Thinning operations in forested ecosystems often focus on reducing both horizontal and vertical continuity to reduce the likelihood of fire transition into the crown and the ability of fire to move horizontally through an area.

As we have shown in the preceding paragraphs, each of the different characteristics in the fuels pentagon can individually contribute to extreme fire behavior. But the potential for extreme fire behavior is further heightened when multiple fuel pentagon characteristics interact. When an adequate quantity of dense, continuous fuels with favorable geometry (high surface area to volume ratio), and chemistry (high fat and low moisture content) is exposed to ignition, extreme fire behavior should be expected. In the next section, we discuss how broader patterns of fuels can lead to such combinations at landscape scales.

Landscape-Scale Fuels and Extreme Fire Behavior

The role of fuels in extreme fire behavior is complex because all of the fuel characteristics in the fuels pentagon interact with one another, within the fire environment context, to determine how fuels burn.

So far, our discussion of fuels has focused on the fuel characteristics that influence flammability at fine scales (particles to small collections of particles). At landscape scales, the distribution and spatial arrangement of fuels significantly affect the potential for fires to spread as well as the mechanisms and rates of spread and associated fire intensities (Miller and Urban 2000). Changes in fundamental fuel characteristics over time, arising from one or more factors, can lead to changes in likelihood of ignition, tendency and rate of spread, or intensity (fig. 4-4). Fuels are

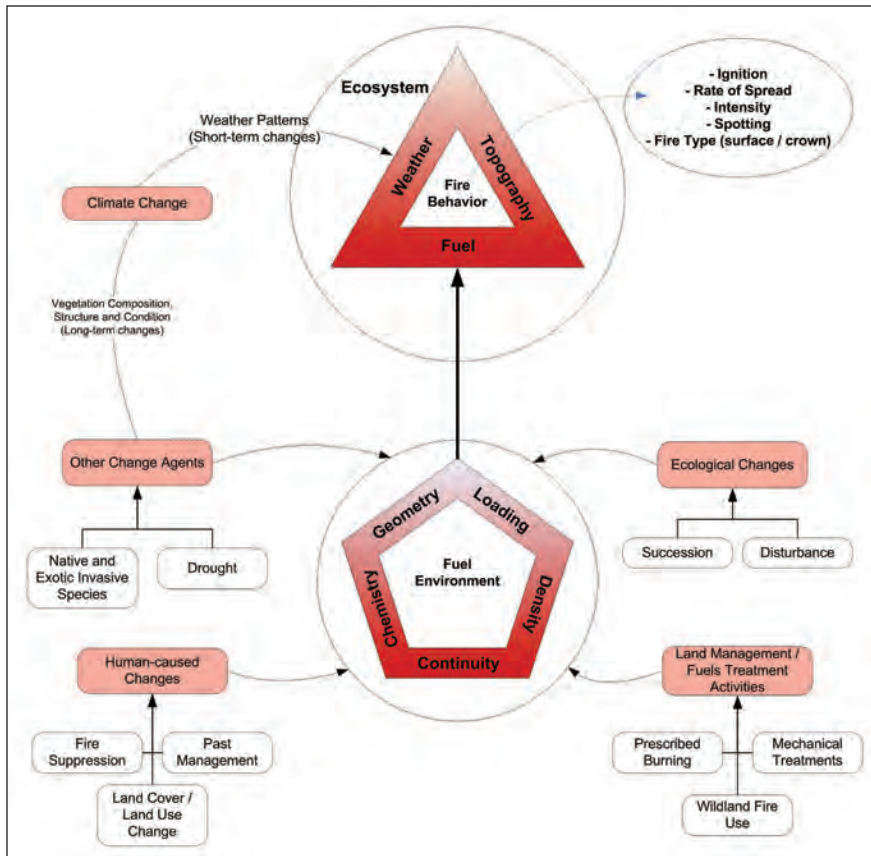

Figure 4-4—Interrelationships between the fire behavior triangle, the fuels environment pentagon, and the change agents that can influence fuel characteristics and subsequent fire behavior.

highly susceptible to changes arising from interactions with the environment, often in complex ways and across multiple spatial and temporal scales.

Landscape Fuel Distribution Patterns

Fuel patterns on the landscape are complex because they result from interactions between the processes of growth and succession, which typically cause fuel accumulations; and natural disturbance processes such as fire, windthrow, insects, and pathogens, which kill individual plants and alter vegetation composition and structure. Disturbance processes are integral parts of natural systems and play a key role in regulating fuel masses and other characteristics as well as opening up resources for new plants to grow. We begin with a discussion on landscape fuel distribution patterns and fuel changes that are driven by natural ecological processes. We then discuss how fuels distributions and characteristics can be affected by management actions such as fire suppression,

fuel treatment, or other land management activities, or by other factors such as climate change or exotic species, all of which can significantly affect fire behavior.

In general, spatial and temporal environmental gradients in temperature, water availability, light, and soil nutrients interact to determine which plants can grow in a given location (Ohmann and Spies 1998, Waring and Running 1998, Whittaker 1967), although specific characteristics of particular vegetation such as seed dispersal mechanisms, competitive relationships with other species, and other factors are also important. Current patterns are also significantly influenced by past patterns. These gradients play a key role not only in the distribution patterns of vegetation but also in how fuels respond to the environment. The pattern and diversity of fuel states at landscape scales can result in conditions that are favorable to the growth of large fires or can disrupt fire growth depending on the circumstances (Viedma et al. 2009).

Natural Fuel Changes

Natural systems are in a constant state of flux as plants respond to the environment, grow, and compete for space and other resources. Many fuel changes are directly related to the weather. Live understory grasses, which may be unlikely to burn, can greatly increase in flammability following a killing frost. Diurnal shifts in fine woody surface fuels on a hot day can rapidly change ignition potentials and surface fire rates of spread. Fires have been observed to significantly increase in intensity over a few seconds simply because the sun comes out from behind a cloud. Desert ecotones in which fire has historically been limited by low fuel continuity can burn extensively after cheatgrass invasions. High-elevation forests, often too wet to burn, can burn with great intensity following a drought.

Fuels interact with weather and climate in several important ways spanning different temporal scales, ranging from diurnal (within a day) to seasonal (across a few months) to interannual (across a few years). These interactions can significantly influence extreme fire behavior as they can result in marked changes in fire behavior.

Temporal dynamics—

One of the most important characteristics of fuels is their temporal dynamics. The physical and chemical characteristics of fuels vary strongly from time scales as short as a few minutes to as long as decades and centuries (Davis 1959). Fuel dynamics play a key role in determining the likelihood and intensity of a fire burning at a given location at a given point in time; significant changes in fuel dynamics often result in extreme fire behavior. We discuss four major fuel dynamic timeframes: diurnal, seasonal, interannual, and successional.

Daily (diurnal)—

Temperature, relative humidity, and wind fluctuate diurnally, affecting the dead fuel moisture content, one of the most critical variables determining whether extreme fire behavior will occur (Brackebusch 1975, Britton et al. 1973, Byram 1940, Fosberg 1970, Fosberg et al. 1981, Pyne et al. 1996, Simard 1968, Steen 1963). The rate at which the dead fuel will respond to these factors depends on the intrinsic

properties of the fuel including particle size, surface-to-volume ratio, and state of decay (Gisborne 1933). For example, a stem of dead grass or a small twig will have a large surface area compared to its volume, and moisture can be absorbed and evaporated rapidly in response to fluctuations in temperature, relative humidity, and wind. On the other hand, large logs have a smaller surface area compared to the volume, and the internal moisture content will respond slower to fluctuations of temperature and relative humidity. Consequently, rapid rates of spread and large releases of energy during extreme fire events often occur during the warmest, driest, and windiest part of the diurnal cycle when the fuels with high surface-to-volume ratios are at their driest. Live fuel moisture content also is important in determining fire behavior and has been shown to vary substantially over the course of a single day (Philpot 1965). These daily variations are not a direct result of changes in temperature and relative humidity but are driven more by physiological plant processes such as transpiration (Nelson 2001). These diurnal fuel fluctuations can strongly influence fire behavior. Generally, the lowest diurnal moisture contents for both live and dead fuels are observed during the hottest and driest parts of the day.

Seasonal—

Fuels change throughout the year because of the cumulative effects of weather and their biophysical cycles. Early in the spring, prior to greenup, last year's grass fuels may be dry enough to burn and fires might ignite and spread. Shortly after greenup, live surface fuels, with extremely high moisture contents may impede the spread of fires until later in the summer when those live fuels cure and are drier. On the other hand, freshly fallen leaves from a deciduous forest often contain large air spaces between individual fuel particles; however, as the leaves become compressed or decay, their surface fire potential decreases. In some cases, standing dead fuels can burn while leaving the live fuels unburned.

Interannual—

Over longer time scales, climate fluctuates owing to the influence of myriad factors. Climate scientists have identified a number of different oscillatory climate patterns such

as the Pacific Decadal Oscillation, the El Niño/Southern Oscillation, and the Arctic Oscillation (Higgins 2007). These interannual cycles can reinforce each other when they are in phase or counteract each other when they are out of phase, so analysis of their interactions is complex. Predictions of the influence of these climate patterns for fire management are often difficult for short time periods because the nature and magnitude of the different cycles are often difficult to determine until after they are well under way (Latif et al. 1998).

In many cases, climate-related influences on fuels may span 2 or more years. Prolonged droughts can debilitate overstory species, drying out foliage and increasing flammability over extensive areas (Allen 2007). Reduction in leaf production can also reduce litter quantities. Depending on the ecosystem, climatic conditions, and site productivity, surface fuel loads can increase rapidly if deposition exceeds decomposition. Patterns can emerge in which wet years spur higher production of surface fuels such as grasses, which then increase the risk of extreme fire behavior in subsequent dry years; this is common in the Southwestern United States (Westerling et al. 2003).

Decadal—

Over longer time scales, fuels change along with vegetation through succession, the process by which ecological communities change in species composition and structure over time following disturbance. Over time, our understanding of this phenomenon has changed from a view as a highly deterministic process (Clements 1936) to a more complex process with numerous interacting influences and multiple potential outcomes (Connell and Slatyer 1977). Although the nature of the underlying dominant processes may vary among ecosystems and ecological communities, it is nearly always the case that vegetation changes over time, modifying the microclimate and other factors affecting growth at the same time.

Succession in forest ecosystems has been studied extensively. Given our focus on fuels and desire for brevity, we touch only on the general concepts. In forest ecosystems, it is common for grasses and forbs to occupy a disturbed

site, giving way to shrubs and small trees over time (Wittinger et al. 1977). As trees get taller, shrub components tend to diminish, and canopy structure changes over time with distinct patterns (Oliver 1980). Openings created by death of individual overstory trees provide opportunities for recruitment of new individuals (Hanson et al. 2011). In most forest ecosystems, succession trends towards a shift in species composition and structure that favors longer lived and typically more shade-tolerant species. For example, pine barrens in the Eastern United States will typically shift to an oak-hickory-dominated forest in the absence of fire (Little and Forman 1998).

Fuels shift along with succession, typically with an accumulation of surface fuels, dependent on the balance between production and decomposition rates (Ryu et al. 2004), often arriving at a semiequilibrium state in the absence of disturbance (Schimmel and Granström 1997). In some cases, shifts in fuel loads and other characteristics of the fuels pentagon may be different at different points along a successional time series; different fuel components also may change at different rates (Agee and Huff 1987).

Vegetation changes occurring through succession can exhibit feedback mechanisms affecting future fires; changes in the light environment occurring as trees grow can alter the surface fuel moisture regime and associated ignition potentials (Tanskanen et al. 2005). Similarly, forest canopies alter the vertical profile of windspeeds and turbulence at spatial scales often several times the canopy height (Amiro 1998); wind acceleration can occur in openings or along edges (Stavey et al. 1994). These canopy-wind field effects are not random or chaotic in nature but rather, coherent and organized (Raupach et al. 1996), which thus likely has significant effects on fire spread rates and intensities.

Disturbance—

Disturbances can promote rapid changes in fuel composition and structure. Many disturbances, such as fire and pathogen attacks, are regular occurrences in a given ecosystem and may generally be limited in extent. Other disturbances, such as climatic changes, windthrow, management action-related impacts, and nonnative invasive species

may also significantly affect the fuel complex. These types of disturbances alter some or all components of the fuels pentagon and thus significantly affect expected fire behavior. Some of the more important natural and human-caused disturbances are discussed below.

Fire—

Disturbance processes influence the accumulation of fuel and the nature of fuel characteristics on the landscape. The interactions between fire, climate, fuels, and the landscape are complex, with influence from both top-down (broad climate patterns) and bottom-up (local fuel and topographic influences) processes (Falk et al. 2011, Heyerdahl et al. 2001). In most regions of the world where fire is a dominant disturbance process, vegetation shows evidence of adaptation to fire, with characteristics that tend to promote fire under conditions favorable to the adaptive strategies of those species (Habeck and Mutch 1973).

Forest pathogens and insects—

Forest pathogens and insects, such as sudden oak death and the mountain pine beetle, are affecting large areas of North American forests (Tkacz et al. 2008). Many of these pathogens and insects are natural parts of the disturbance cycle of forests and endemic attacks are common and help to maintain uneven-aged stand structures. The interaction of pathogens and insects with their host as well as their ability for spread, influence the rate at which mortality occurs and therefore influence the resulting fuels complex. In some cases, the mortality resulting from insects and diseases is a slow process affecting relatively small areas across the landscape; however, in other cases, epidemic outbreaks may occur that can cause widespread mortality and affect large areas. Such events are particularly important in fuels owing to the rapid and widespread change in the fuels complex that is associated with the outbreak. Often, our understanding of how fire behavior changes in insect and pathogen-infested stands is still limited but is an area of active research. Current concerns have particularly arisen regarding the effect of insect outbreaks in the Western United States. Current bark beetle outbreaks throughout the Western United States have infested a large number of hectares in a relatively short time. However, fuel conditions continuously

change over several years following bark beetle attacks. Early during an outbreak, foliar moisture content decreases rapidly as leaves senesce, significantly increasing flammability (Jolly et al. 2012); similar effects have been observed as a result of pathogens such as sudden oak death (Kulijan and Varner 2010). Although this increased flammability likely diminishes in a given tree after a few years as foliage falls, increased flammability at stand or landscape scales may persist for several years as the attack continues to unfold (Jenkins et al. 2012). Different components of the fuel bed continue to change for decades after an attack (Jenkins



W.M. Jolly

Figure 4-5—Mountain pine beetle-attacked lodgepole pine tree torching from a single point source ignition of the lowest branch during a prescribed burn on the Seeley Lake Ranger District, Lolo National Forest, in 2011.

et al. 2008; Page and Jenkins 2007a, 2007b). Studies have reported an assortment of changes in fire behavior in forests infested with bark beetles including increases in spread rates, flame lengths, and fire intensities (Page and Jenkins 2007b, Valachovic et al. 2011), and increase in crown fire potential (Hoffman et al. 2012, Kuljian and Varner 2010). Other studies report a reduction in the crown fire risk from reductions in the crown bulk density of infested stands (Simard et al. 2011). Intuitively, if the foliar moisture content of leaves or needles decreases by an order of magnitude and no other structural changes occur, one would expect that infected trees would be more flammable during or immediately following attack. Although research reports are contradictory, observations of free-burning fires in Canada

and the United States support these conclusions. For example, figure 4-5 shows a mountain pine beetle attacked tree, before any foliar loss has occurred, readily torching from a single point source ignition of its lowest branch. Regardless of the specific influences on fire behavior, forest pathogens and insects greatly affect the temporal fuel dynamics of infested stands, and these changes are likely manifested over decades.

Wind—

Wind disturbances, such as hurricanes, tornados, blow-downs and micro-bursts, can greatly affect the fuel structure of a given ecosystem and can alter those fuels in minutes. In general, leaves may be stripped from standing stems; branches and whole stems may be broken and



Jon Wallace

Figure 4-6—Blowdown of sparsely stocked pines in southern Mississippi after Hurricane Katrina, September 2005.

deposited as surface fuels, which significantly increases surface fuel masses (Loope et al. 1994, Myers and van Lear 1998). An example of rapid fuel alterations after Hurricane Katrina is shown in figure 4-6. These events change the continuity, mass, and arrangement of the surface and aerial fuels and eventually will change the surface fuel moisture regime as the green foliage of broken stems dies and more solar radiation can penetrate through the canopy to the surface (Loope et al. 1994). In the Boundary Waters Canoe Area Wilderness of Minnesota, a blowdown event affected over 150 000 ha of the forested land and vastly altered the fuel complex. After that event, 100-h and 1,000-h surface fuel masses were found to be almost twice as high as those found in adjacent, undisturbed stands (Woodall and Nagel 2007). Additionally, these events may preferentially affect larger diameter, shade-intolerant trees and thus substantially alter subsequent fuel structures (Rich et al. 2007). These surface fuel alterations promote fires that burn intensely and are hard to contain because of restricted access into affected stands. After this event, large fires ensued such as the 13 000-ha Cavity Lake Fire of 2006, the 29 000-ha Ham Lake Fire of 2007, and the 38 000-ha Pagami Creek Fire in 2011.

Anthropogenic (Human-Caused) Changes in Fuels

While many fuel changes are natural processes, some fuel changes have been induced by human action or inaction. Some of these changes are discussed below.

Human activities can affect extreme fire behavior by changing the dynamic interactions between succession and natural disturbance processes. Past management activities or land use practices have resulted in lasting impacts on fuel characteristics. In many parts of the Western United States, episodes of heavy grazing over several decades essentially eliminated surface fuels, facilitating the development of a thick understory of shade-tolerant species, which would have likely been killed or substantially thinned by fire otherwise (Heyerdahl et al. 2006). In southwestern ponderosa pine forests, forest structure has changed from a fire-dominated, low-density stand structure characterized by large trees to vast expanses with thickets of small trees

owing to the combined effects of logging, grazing, and fire suppression (Allen et al. 2002). In both cases, these changes represent a landscape-scale shift in fuel continuity and geometry with significant implications for extreme fire behavior. Anthropogenic influences can also disrupt fuel continuity, reducing the likelihood of fire spread. A simulation study assessing changes in fuel connectivity in the Southeastern United States suggests that a small proportion of landscape area, such as roads, can significantly impede fire spread with certain fuel types (where spotting distances are shorter) at landscape scales (Duncan and Schmalzer 2004). This can produce unintended consequences but can also be used as a management strategy in certain circumstances.

Fire suppression plays a role in altering fuel masses and continuity. Fire suppression is often considered to have resulted in increases in fire intensity and resistance to control efforts. This appears to be the case in the Southwestern United States and in many dry forest types, where fuel accumulations related, at least in part, to fire suppression, have resulted in intense fires uncharacteristic of those frequent fire regime areas (Allen et al. 2002).

Suppression limits the reductions in surface fuels that are common in areas with short fire-return intervals and allows the growth of shade-tolerant species in the understory that often serve as ladder fuels to carry fires from the surface into the crowns of trees that might not normally be affected by low-intensity surface fires. Fire plays an important role in opening up growing space for seedlings, so suppression may affect regeneration, particularly for fire-adapted species (Lunan and Habeck 1973). Other changes may occur as well. For example, in a mixed-conifer forest in California, small tree density and surface fuels increased with fire suppression (Parsons and DeBenedetti 1979).

However, fire suppression does not alter all fuel complexes equally. In some cases, the role of fire suppression is more difficult to estimate as it can be obscured by climate or its effects may not be immediately perceived. Keeley et al. (1999) demonstrated that fire suppression had little impact on the frequency and extent of wildfires burning in the California chaparral, and Johnson et al. (2001) suggested that

the same may be true for closed-canopy coniferous forests in the boreal regions. Overall, decades of fire suppression may differentially affect the fuel dynamics of various ecosystems, and we must understand how these changes might manifest themselves as changes in fire behavior.

A century of fire ecology research has established that fire is a natural part of wildland ecosystems, and fire management practices are changing to facilitate a broader recognition of this. Rather than requiring suppression in all cases, fire management policies now support a more nuanced and flexible view of fire’s role on the landscape, and allow for portions of a fire to be managed for resource benefit while other portions may be suppressed. Decision support systems that support this process are currently in use in the United States and continue to be revised. Recognition of the natural role of fire in the landscape helps guide proactive management practices that will be helpful in years to come as we continue to adapt to a changing environment.

Climate Change and Other Agents of Fuel Change

Fire managers face the prospect of ecosystems that are changing rapidly and often in several ways at once. Many of these changes are exacerbated by climatic changes. Climatic changes can influence extreme fire behavior by altering both the short-term fire weather environment and by influencing longer term changes in vegetation composition, condition, and structure (fig. 4-7). Understanding the implications of these changes is essential for determining, and potentially mitigating, the role of fuels in extreme fire behavior.

Climate change—

Although climate change is represented as controversial in the popular media, there is little debate in the scientific community that climate change is occurring, that it is

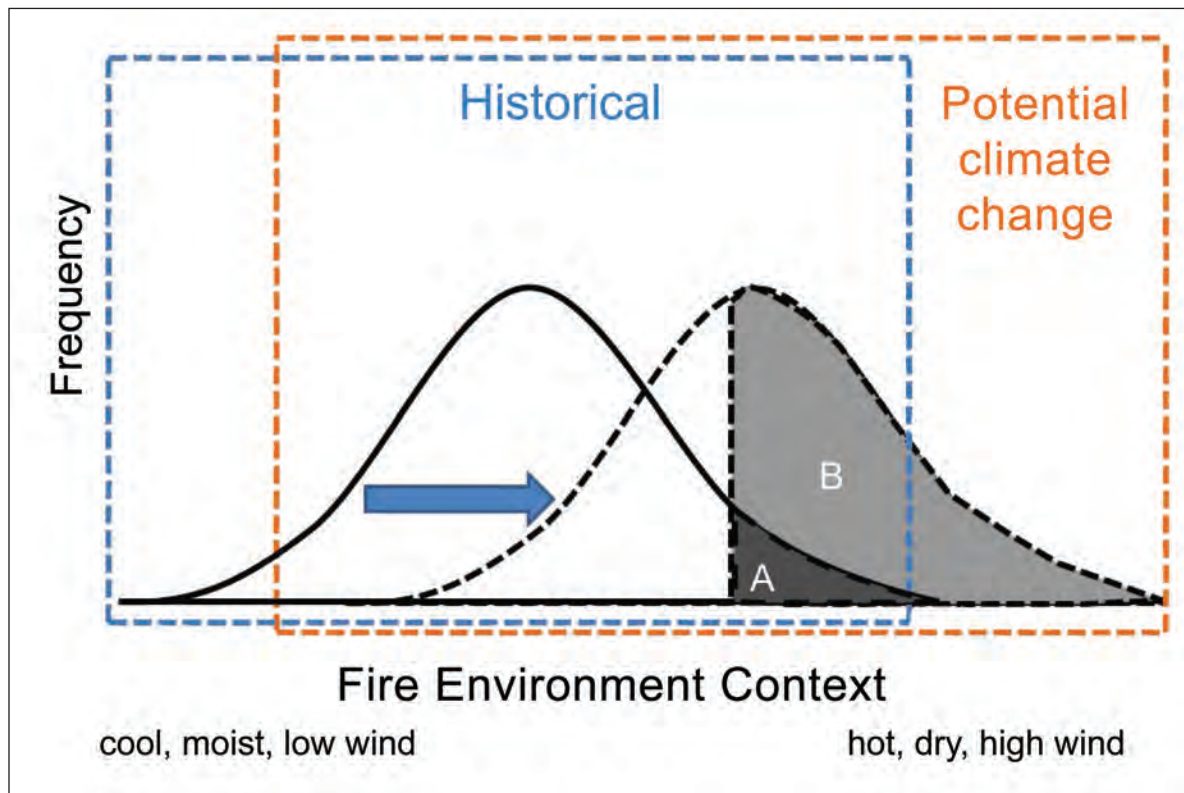

Figure 4-7—Changes in climate have significant implications for fire management in the future. A climate shift towards hotter and drier conditions can greatly alter the likelihood of events. Hot and dry events that may have been rare historically (area under curve, A) may become much more common (area under curve, B; note that B includes A).

anthropogenic in nature, and that it has profound consequences for ecosystems and human communities throughout the globe (Pachauri 2007). Globally, climate change is resulting in increasing temperatures, widespread melting of both polar and continental ice, and sea level rise. Changes in precipitation vary among regions (Pachauri 2007). Many semiarid areas, such as the Western United States, are anticipated to undergo substantial decreases in water resources as changes in precipitation have more pronounced effects than temperature changes in arid regions (Conant et al. 1998). Additionally, extreme weather events such as heat waves and subsequent droughts may be more variable and less predictable (Schar et al. 2004).

Earlier spring snowmelt dates combined with higher temperatures have lengthened fire seasons in the Western United States (Westerling et al. 2006), and this trend is expected to continue. This shift towards increased temperatures may significantly alter the likelihood of occurrence of weather patterns associated with extreme fire behavior. At regional scales, climate change effects are expected to spur increased fire activity (Flannigan et al. 2000). In many cases, these increases in fire activity are expected to accompany increased severity of ecological effects. In recent years, large, stand-replacing wildfires have occurred in Southwestern ponderosa pine stands where such fires were extremely rare in the past; these fires likely result from both climate and fuel-change induced effects (Allen et al. 2002).

A shifting landscape: spatial shifts in species distributions—

Changes in temperature and water alter growing conditions across the landscape. These shifts favor some species while harming others, eventually altering the spatial distribution of different species (Iverson and Prasad 2002). For example, tree lines might shift upwards in elevation as temperature conditions become more favorable to tree growth (Grace et al. 2002). During this change, existing species at treeline might experience competition from lower elevation species expanding into their range (MacDonald et al. 2000). In some cases, temperature changes may differentially affect fuels at different elevations. For example, during an extreme heat wave event, vegetation at low elevations was severely

water stressed while vegetation at higher elevations grew more vigorously because the snow-free period was lengthened (Jolly et al. 2005).

Shifts in species distributions are typically expected to take place slowly (Grace et al. 2002). However, recent evidence suggests that they can occur very rapidly when thresholds of environmental conditions are passed. Widespread tree mortality has been observed in temperate forests in the Western United States (Van Mantgem et al. 2009), and similar rapid, landscape-scale pinyon pine die-off under drought conditions has been reported at lower elevations in pinyon-juniper woodlands (Breshears et al. 2005, 2008). In the short to medium term, these die-off situations can represent a potentially disastrous increase in flammability leading to increased risk of extreme fire behavior. Over longer time periods, if persistent, these climate change effects may result in a wholly different species composition and structure, such as a shift from forest to lower density woodlands or from shrublands to desert.

Invasive species—

Fire managers must also adapt to the spread of invasive species (Vitousek et al. 1997). Invasive species can be either native or exotic. “Exotic species” generally refers to any species that falls outside of its native range. They are usually from other continents, but many native species can also be considered invasive when they move into areas that they otherwise would not occupy. Both native and exotic invasive species can significantly alter the fuel dynamics. More than 2,000 exotic species have been introduced into the United States and the majority of these introductions have been human caused (Vitousek et al. 1997). The resulting changes in the fuel complex can have far-reaching impacts on the disturbance cycle of a given ecosystem (Mack and D’Antonio 1998). Where invasive species are physically similar to other species, such as the invasion of a grass into an ecosystem already dominated by grasses, they tend to alter fire behavior by changing fuel masses (D’Antonio 2000). In contrast, when the invasive species have no analogous life form within a given ecosystem, they can significantly influence the disturbance cycle of the system into which they are introduced (D’Antonio 2000). While these species also alter

fuel masses, they can also change other fuel characteristics such as fuel continuity, density, and chemistry. These fuel changes are generally important to fire managers, but, frequently, management tools such as prescribed burning may actually promote or maintain fire-adapted invasive species to the detriment of native species (Kerns et al. 2006).

Epidemic insect and pathogen outbreaks—

While frequent, low-intensity pathogen and insect attacks are common, occasionally pathogens or insects may rapidly reproduce and attack vast areas, killing vegetation and altering fuel structures. These attacks can induce widespread, rapid changes in the fuel complex that can last for decades. One example of an epidemic outbreak is the current widespread infestation of mountain pine beetles (*Dendroctonus ponderosae*) throughout the Western United States. These outbreaks generally occur when there is an abundance of host vegetation, high concentrations of pathogens, and favorable weather (Raffa et al. 2008). Fuel changes following an outbreak are very dynamic, and these changes can either increase or decrease expected fire behavior by changing all five sides of the fuel pentagon to some degree (Jenkins et al. 2008). For example, foliar moisture content drops rapidly after a successful attack (Kuljian and Varner 2010) altering the fuels chemistry and little else. Later, when dead, aerial vegetation falls to the ground, surface fuel masses, continuity, and geometry are altered (Page and Jenkins 2007a). All of these changes manifest themselves as changes in the potential for extreme fire behavior that can span millions of hectares in some instances.

Climatic changes can strongly affect both the spread of invasive species and the likelihood and extent of epidemic pathogen outbreaks. For example, plant species distributions are strongly related to temperature and precipitation. Both temperature and precipitation interact to define this species envelope and thus no single component of climate change can be considered in isolation. Research has suggested that expected climatic changes can vastly alter the land area suitable for invasion by species such as *Bromus tectorum* (cheatgrass) (Bradley 2009). However, not all climatic changes will promote invasive species. Some work suggests that future climates may be less favorable for exotic species

and thus may present opportunities for restoration (Bradley et al. 2009). Climatic changes may also significantly influence the potential for pathogen or insect epidemics. For example, warmer temperatures might permit insects such as the mountain pine beetle to attack trees at higher latitudes and higher elevations (Bentz et al. 2010). Climatic changes are a strong secondary driver of many types of fuel changes and thus should always be considered when attempting to characterize long-term expectations in fuel dynamics.

Fuels Management Options That Reduce Extreme Fire Behavior Potential

Fuels, weather, and topography interact to dictate how fires burn. However, fuels can be manipulated to lessen extreme fire behavior potential through different fuels management strategies. The terms fuel management and fuel treatment are often used to denote activities that are undertaken to either meet some land management or ecological objective or to reduce the potential for extreme fire behavior (Reinhardt et al. 2008). Various fuel treatment actions are undertaken to change one or more of the elements of the fuels pentagon and subsequently change some component of fire behavior such as rates of spread or intensity of a fire burning in a given fuel stratum (fig. 4-4). Fuel treatment projects are objective-driven, where a particular problem is identified and many options are evaluated to meet that objective. Ultimately, some strategy must be developed that alters fuel characteristics and achieves specific, and ideally measurable, reductions in the potential for extreme fire behavior.

Primarily, there are four types of fuel treatment actions that are undertaken to achieve these objectives: reduction or redistribution of surface fuels, increasing the height to live crown, decreasing crown density, and retaining large trees of fire-resistant species (Agee and Skinner 2005).

Reduction of Surface Fuels

The reduction of surface fuels influences many factors of the fuels pentagon such as continuity, quantity, geometry and density, with the potential to alter both surface fire rates of spread and fire intensity as well as the likelihood that fires will carry from the surface into the crowns (Van Wagner 1977). For this reason, surface fuel reductions

have the potential to affect many characteristics of extreme fire behavior. Many activities can be employed to reduce surface fuels, such as prescribed fire, chaining, mastication, and grazing. One main consideration for these types of fuels treatment activities is the longevity of the treatment. Fuels are dynamically influenced by climate and thus areas where surface fuels can rapidly accumulate may require frequent treatments to maintain effectiveness. In some cases, rapid fuel accumulations, like those found in the Southeastern United States, may limit effectiveness to less than a decade (Brose and Wade 2002).

Increasing the Height to Live Crown

Crown fire is generally thought to be a two-stage process (see chapter 9 of this volume). The first part is called initiation, where a surface fire is carried into the crowns; the second part is the propagation, where crown fires are carried from tree crown to tree crown (Van Wagner 1977). Increasing the height to live crown effectively increases the amount of heat that must be sustained from a given surface fire to preheat and ignite the crown fuels above. Thus, this fuels treatment principle is primarily used to reduce crown fire potential.

Decreasing Crown Density

The second component of crown fire potential, propagation, is primarily influenced by canopy density. Therefore, fuels treatments aimed at reducing crown fire spread potential must focus on reducing crown continuity and density. These objectives are generally met using some form of mechanical thinning. However, thinning alone is generally an insufficient fuels treatment option because postthinning residuals can increase surface fuel masses, thereby significantly increasing surface fire intensities and the potential for passive crown fires. Because of this, thinning is generally combined with some form of surface fuel reduction such as prescribed fire or pile burning. Not only can thinning influence canopy density, it can also influence the height to live crown of the entire stand if tree selection is based on diameter classes. Low thinning, where trees are removed from the smallest diameter classes, can simultaneously increase stand-scale canopy base heights while decreasing canopy density (Agee and Skinner 2005).

Retaining Large, Fire-Resistant Trees

The fourth principle of fuels treatment is the development of strategies for retaining the largest and most fire-resistant trees. Large trees generally have thick bark and high crown base heights. Additionally, stocking densities of large trees are generally low and thus reduce crown density and continuity. These fuel conditions can reduce the likelihood of crown fire and potentially promote a fire regime of more frequent and lower intensity fires than would be common in these cover types.

Negative Influences of Fuels Treatments

Fuels and weather are strongly coupled and interact to influence the microclimate of a given stand. These couplings and interactions are important to consider when developing strategies for fuels management. Activities such as thinning, while effective at reducing canopy bulk density, may also increase surface windspeeds because of the reduction in aerodynamic drag (Landsberg and James 1971). Additionally, removing trees may increase the amount of solar radiation that reaches the forest floor, potentially influencing surface fuel moistures. Ultimately, strategies aimed at effectively reducing the likelihood of extreme fire behavior must be considered within the context of both the direct changes in fuel characteristics and their indirect influences on other components of the fire environment.

Temporal-and Spatial-Scale Considerations for Hazardous Fuels Management

It is important to consider the temporal and spatial scale of fuels management efforts to ensure that treatments are targeted where they are likely to have the largest and longest impact. When available data permit, it is helpful to consider treatments within the context of the historical fire regimes for a given area. Ideally, fuels treatments should be comparable to both the spatial and temporal scales of natural disturbances. As such, small and scattered treatments, while potentially effective for small areas, may be ineffective in reducing extreme fire behavior at landscape scales, particularly in areas in which larger fires have historically dominated landscape patterns. Within the context of reducing extreme fire behavior potential, landscape-scale

fuel reduction activities, such as fire managed for resource benefit, offer certain advantages as these activities can often be accomplished over larger areas than is feasible with comparable mechanical or prescribed fire fuels treatments. Generally, it has been recommended that hazardous fuels treatments be focused on restoring areas where low-severity fires historically dominated but that now have substantial fuel accumulations owing to fire exclusions (Brown et al. 2004).

Future Directions

The primary take-home message from volume 1 of the extreme fire behavior review (Werth et al. 2011) and this volume, as well, is that fire is quintessentially a three-dimensional and nonsteady state phenomenon. In many ways, the current limits in our capacity to understand, assess, and predict extreme fire behavior arise from the fact that we describe and model fuels and fire in overly simplistic, one- or two-dimensional frameworks that fail to include the three-dimensional nature of fire.

Sampling methods for measuring many aspects of different fuel bed components have been developed (Lutes et al. 2006), and large ecosystem databases such as Forest Inventory and Analysis (Miles et al. 2001) provide objective and scientifically credible information on fuels for specific ecosystems. Yet, the science of fuels sampling, measurements, and modeling is still in early stages because current approaches fail to adequately capture fuel heterogeneity or address discontinuities within the fuel bed.

One of the main reasons for this is that systems for describing fuels have largely been oriented towards providing inputs for fire models that can only accept a limited scope of fuel complexity. The systems used operationally in the United States such as FARSITE (Finney 2004), Nexus (Scott 1999), Fire and Fuels Extension to the Forest Vegetation Simulator (Reinhardt et al. 2003), BehavePlus (Andrews et al. 2008), and the Fuel Characteristic Classification System (Ottmar et al. 2007, Sandberg et al. 2007) are based primarily on a semiempirical surface fire spread model (Rothermel 1972). Although these systems model crown fire spread, this is still carried out through links to Rothermel's empirical crown fire rate of spread model

(Rothermel 1991) via Van Wagner's crown fire initiation and propagation models (Van Wagner 1977, 1993). In these modeling systems, surface fuels are assumed to be homogeneous, continuous, and contiguous to the ground, and crown fuels are considered as a homogeneous layer of uniform height above the ground, depth, and bulk density. Different mechanisms of heat transfer (i.e., radiative, convective, or conductive) are not explicitly modeled, nor are transitory fire behaviors. Fuel models used as inputs to this modeling system consist of sets of parameters (e.g., surface area to volume, heat content, and fuel load) describing homogeneous fuel beds (Anderson 1982, Scott and Burgan 2005), in which fuel heterogeneity or discontinuities are not well described.

Thus, while detailed fuels data, such as tree lists with individual tree attributes or fuels transect data with multiple measurements of litter depth might be available, only summarized quantities such as averages are used to represent the homogeneous case used in fire behavior calculations. For example, a single value for canopy base height is used to represent a stand of trees when in fact there is usually much variability in individual tree crown base heights.

The use of these averaged values results in lower sensitivity to fuels and fuel changes because the geometry and spatial configuration of fuels are not accounted for. Forest stands that are quite different in composition and structure could appear very similar with respect to their representation. For most operational purposes, spatially explicit fire simulations are carried out with models such as FARSITE with spatial resolution of cells 30 m on a side (Rollins and Frame 2006). Although this cell size is very small compared to most landscapes, it is very large with respect to the spatial scale at which fire tends to interact with wildland fuels (Finney et al. 2010). This homogenization of fuels inputs arising from use of these summarized quantities, thus imposes a spatial scale on fuels that may not be realistic. An additional disadvantage to these simplified fuel and fire models is that potentially important fuel/fire interactions, such as the effect of tree canopies on winds approaching and around a fire, cannot be addressed in detail.

Future improvements in our capabilities to model fuels and fire in three dimensions will increase our understanding

of the role of fuels in extreme fire behavior, and vice versa. While these capabilities are not yet fully developed, recent advances show promise and provide a potential view of things to come.

New Developments in Fuels Mapping

New technologies are emerging, such as airborne light detection and ranging (LiDAR) systems that can provide detailed measurements of forest canopies over large areas with accuracies comparable to on-the-ground field measurements in a fraction of the time that field crews would take (Lefsky et al. 1999). Such data are increasingly common and available for use in developing detailed fuels maps. Other recent developments include the use of ground-based LiDAR systems, which provide very detailed views of canopy structure (Parker et al. 2004). Such systems provide an unprecedented depth of data for characterizing the spatial structure, heterogeneity of forest canopies (Seidel et al. 2012), and associated fuels quantities (Garcia et al. 2011).

New Developments in Fire Behavior Modeling

Mechanistic physics-based fire behavior models have emerged, capable of addressing many aspects of fire behavior currently not addressed by operational fire models. These computational fluid dynamics (CFD) models simulate fire behavior dynamically over time within a three-dimensional spatial domain, describing the dynamics according to equations for the conservation of mass, momentum, energy, and chemical species. Unlike operational models, which assume steady-state rates of fire spread (Rothermel 1972), CFD models are self-determining and are thus capable of addressing fire-fuel interactions arising from spatial variability within the fuel bed, and fire-atmosphere interactions (fig. 4-8). There are several such models, but the most developed at this point are FIRETEC (Linn and Harlow 1997, Linn et al. 2002) and the Wildland Fire Dynamics Simulator (Mell et al. 2009).

Of particular significance to this chapter is the capacity of these models to address fuel heterogeneity. Computational fluid dynamics models have been used to model fire from the scale of individual trees (Mell 2006, 2009) in laboratory experiments to larger scale landscape fuels

environments such as grasslands and woodlands (Cunningham and Linn 2007, Linn et al. 2005). These models can deal with very detailed fuels scenarios at the spatial scales where fire is very sensitive to fuel heterogeneity and spatial configuration. As each tree, or even different portions of each tree, within a stand could have different fuel characteristics, these models have great potential for examining and improving our understanding of the complex roles of fuels in extreme fire behavior, as well as to elucidate the range of weather or topographic conditions under which fire is less sensitive to fuels. An additional important aspect of these models is that they can address the dynamic interactions between the fuels, fire, atmosphere, and topography in extreme fire behavior (Cunningham and Linn 2007). No other modeling frameworks can address these critical and complex interactions.

One potential limitation is that these complex fire models require detailed three-dimensional fuels inputs, which are difficult to directly measure. Standard forestry inventory data only provide lists of trees and basic attributes, such as height and diameter, and lack the more fundamental fuel characteristics such as bulk density. Although methods have been developed to estimate bulk density at the stand scale through indirect measurements (Keane et al. 2005), more sophisticated approaches, typically involving modeling, are required to address this need at finer spatial scales. To accommodate this need, Parsons (Parsons et al. 2011) has developed and is continuing to improve the FUEL3D model. This model uses forest inventory data and incorporates the pipe model theory and a simple three dimensional recursive branching approach to model the distribution of fuel within individual tree crowns. This model will address new fuel characteristic requirements from current mechanistic physical-based fire models coming on line and will improve our ability to assess the potential of extreme fire behavior.

Concluding Remarks

Throughout this chapter we have attempted to paint, in broad strokes, the role of fuels in extreme fire behavior. We demonstrate that fuels play a critical, but complex, role in which key characteristics of fuels, summarized in the fuels pentagon, and their composition, arrangement, and land-

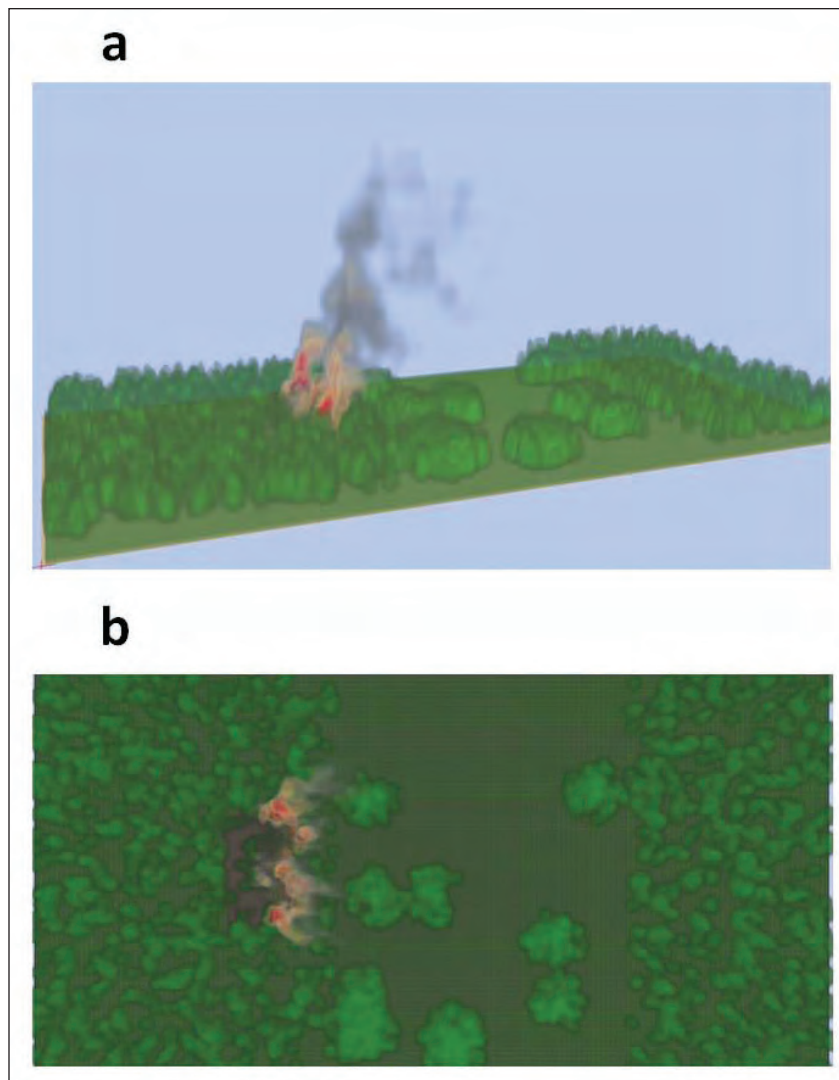

Figure 4-8—View from two perspectives: (a) oblique and (b) overhead of a dynamic fire simulation with the FIRETEC, physics-based fire model (graphic developed by Eunmo Koo, Los Alamos National Laboratory).

scape pattern, can change, often rapidly, in response to both natural and human influences. These changes can result in significant increases in flammability that can affect the nature and magnitude of how fires burn at landscape scales. We bring in the big picture view of a dynamic landscape, changing in many ways at the same time and across scales, in response to climate change, anthropogenic activities, and feedbacks with other agents of change such as invasive species or beetle epidemics. All of these factors play a role in the occurrence of extreme fire behavior.

We concluded with discussion of technological changes, in fuels mapping and modeling, and in fire behavior modeling, that offer new perspectives on the nature and drivers of extreme fire behavior. With hotter, drier and longer fire seasons; prolonged drought; invasive; species and large-scale beetle attacks all affecting wildland fuels, looking ahead, it is apparent that extreme fire behavior is not going to disappear. Faced with these challenges, our best answer is to build stronger ties between the fire science and fire management communities and work together for a better future.

Literature Cited

- Agee, J.K.; Huff, M.H. 1987.** Fuel succession in a western hemlock/Douglas-fir forest. *Canadian Journal of Forest Research*. 17(7): 697–704.
- Agee, J.K.; Skinner, C.N. 2005.** Basic principles of forest fuel reduction treatments. *Forest Ecology and Management*. 211: 83–96.
- Alessio, G.A.; Penuelas, J.; Llusia, J.; Llusia, J.; Ogaya, R.; Estiarte, M.; De Lillis, M. 2008.** Influence of water and terpenes on flammability in some dominant Mediterranean species. *International Journal of Wildland Fire*. 17: 274–286.
- Allen, C.D. 2007.** Interactions across spatial scales among forest dieback, fire, and erosion in northern New Mexico landscapes. *Ecosystems*. 10: 797–808.
- Allen, C.D.; Savage, M.; Falk, D.A.; Suckling, K.F.; Swetnam, T.W.; Schulke, T.; Stacey, P.B.; Morgan, P.; Hoffman, M.; Klingel, J.T. 2002.** Ecological restoration of southwestern ponderosa pine ecosystems: a broad perspective. *Ecological Applications*. 12: 1418–1433.
- Amiro, B.D. 1990.** Drag coefficients and turbulence spectra within three boreal forest canopies. *Boundary-Layer Meteorology*. 52: 227–246.
- Anderson, H. 1970.** Forest fuel ignitibility. *Fire Technology*. 6: 312–319.
- Anderson, H.E. 1982.** Aids to determining fuel models for estimating fire behavior. Gen. Tech. Rep. GTR-INT-122. Ogden, UT: U.S. Department of Agriculture, Forest Service, Intermountain Forest and Range Experiment Station. 22 p.
- Andrews, P.L.; Bevins, C.D.; Seli, R.C. 2003.** BehavePlus fire modeling system, version 2.0: user's guide. Gen. Tech. Rep. RMRS-GTR-106. Ogden, UT: U.S. Department of Agriculture, Forest Service, Rocky Mountain Research Station. 142 p.
- Andrews, P.L.; Bevins, C.D.; Seli, R.C. 2008.** BehavePlus fire modeling system version 4.0 user's guide. Gen. Tech. Rep. RMRS-GTR-106. Revised. Ogden, UT: U.S. Department of Agriculture, Forest Service, Rocky Mountain Research Station. 116 p.
- Babrauskas, V. 2006.** Effective heat of combustion for flaming combustion of conifers. *Canadian Journal of Forest Research*. 36: 659–663.
- Babrauskas, V.; Peacock, R.D. 1992.** Heat release rate: the single most important variable in fire hazard. *Fire Safety Journal*. 18: 255–272.
- Bentz, B.J.; Régnière, J.; Fettig, C.J.; Hansen, E.M.; Hayes, J.L.; Hicke, J.A.; Kelsey, R.G.; Negron, J.F.; Seybold, S.J. 2010.** Climate change and bark beetles of the western United States and Canada: direct and indirect effects. *BioScience*. 60: 602–613.
- Brackebusch, A.P. 1975.** Gain and loss of moisture in large forest fuels. Res. Pap. RP-INT-173. Ogden, UT: U.S. Department of Agriculture, Forest Service, Intermountain Forest and Range Experiment Station. 50 p.
- Bradley, B.A. 2009.** Regional analysis of the impacts of climate change on cheatgrass invasion shows potential risk and opportunity. *Global Change Biology*. 15: 196–208.
- Bradley, B.A.; Oppenheimer, M.; Wilcove, D.S. 2009.** Climate change and plant invasions: restoration opportunities ahead? *Global Change Biology*. 15: 1511–1521.
- Breshears, D.D.; Cobb, N.S.; Rich, P.M.; Price, K.P.; Allen, C.D.; Balice, R.G.; Romme, W.H.; Kastens, J.H.; Floyd, M.L.; Belnap, J.; Anderson, J.J.; Myers, O.B.; Meyer, C.W. 2005.** Regional vegetation die-off in response to global-change-type drought. *Proceedings of the National Academy of Sciences of the United States of America*. 102(42): 15144–15148.

- Breshears, D.D.; Myers, O.B.; Meyer, C.W.; Barnes, F.J.; Zou, C.B.; Allen, C.D.; McDowell, N.G.; Pockman, W.T. 2008.** Tree die-off in response to global change-type drought: mortality insights from a decade of plant water potential measurements. *Frontiers in Ecology and the Environment*. 7: 185–189.
- Britton, C.M.; Countryman, C.M.; Wright, H.A.; Walvekar, A.G. 1973.** The effect of humidity, air temperature, and wind speed on fine fuel moisture content. *Fire Technology*. 9: 46–55.
- Broido, A.; Nelson, M.A. 1964.** Ash content: its effect on combustion of corn plants. *Science*. 146: 652–653.
- Brose, P.; Wade, D. 2002.** Potential fire behavior in pine flatwood forests following three different fuel reduction techniques. *Forest Ecology and Management*. 163: 71–84.
- Brown, J.K. 1971.** A planar intersect method for sampling fuel volume and surface area. *Forest Science*. 17: 96–102.
- Brown, R.T.; Agee, J.K.; Franklin, J.F. 2004.** Forest restoration and fire: principles in the context of place restauración de bosques y fuego—principios en el contexto del sitio. *Conservation Biology*. 18: 903–912.
- Burgan, R.E.; Sussott, R.A. 1991.** Influence of sample processing techniques and seasonal variation on quantiles of volatile compounds of gallberry, saw-palmetto, and wax myrtle. *International Journal of Wildland Fire*. 1: 57–62.
- Byram, G.M. 1940.** Sun and wind and fuel moisture. *Journal of Forestry*. 38: 639–640.
- Catchpole, E.A.; Catchpole, W.R. 1991.** Modelling moisture damping for fire spread in a mixture of live and dead fuels. *International Journal of Wildland Fire*. 1: 101–106.
- Clements, F.E. 1936.** Nature and structure of the climax. *Journal of Ecology*. 24: 252–284.
- Conant, R.T.; Klopatek, J.M.; Malin, R.C.; Klopatek, C.C. 1998.** Carbon pools and fluxes along an environmental gradient in northern Arizona. *Biogeochemistry*. 43: 43–61.
- Connell, J.H.; Slatyer, R.O. 1977.** Mechanisms of succession in natural communities and their role in community stability and organization. *American Naturalist*. 1119–1144.
- Cunningham, P.; Linn, R.R. 2007.** Numerical simulations of grass fires using a coupled atmosphere–fire model: dynamics of fire spread. *Journal of Geophysical Research*. 112: D05108.
- D’Antonio, C.M. 2000.** Fire, plant invasions, and global changes. In: Mooney, H.A.; Hobbs, R.J. eds. *Invasive species in a changing world*: 65–93.
- Davis, K. 1959.** *Forest fire: control and use*. McGraw-Hill, Inc., New York, Toronto, London.
- De Lillis, M.; Bianco, P.M.; Loreto, F. 2009.** The influence of leaf water content and isoprenoids on flammability of some Mediterranean woody species. *International Journal of Wildland Fire*. 18: 203–212.
- Dimitrakopoulos, A.P.; Papaioannou, K.K. 2001.** Flammability assessment of Mediterranean forest fuels. *Fire Technology*. 37: 143–152.
- Duncan, B.W.; Schmalzer, P.A. 2004.** Anthropogenic influences on potential fire spread in a pyrogenic ecosystem of Florida, USA. *Landscape Ecology*. 19: 153–165.
- Falk, D.A.; Heyerdahl, E.K.; Brown, P.M.; Farris, C.; Fule, P.Z.; McKenzie, D.; Swetnam, T.W.; Taylor, A.H.; Van Horne, M.L. 2011.** Multi-scale controls of historical forest-fire regimes: new insights from fire-scar networks. *Frontiers in Ecology and the Environment*. doi:10.1890/100052.
- Fernandes, P.M.; Rego, F.C. 1998.** A new method to estimate fuel surface area-to-volume ratio using water immersion. *International Journal of Wildland Fire*. 8: 59–66.
- Finney, M.A. 2004.** FARSITE: Fire Area Simulator-model development and evaluation. Res. Pap. RMRS-RP-4. Ogden, UT: U.S. Department of Agriculture, Forest Service, Rocky Mountain Research Station. 47 p.

- Finney, M.A.; Cohen, J.D.; Grenfell, I.C.; Yedinak, K.M. 2010.** An examination of fire spread thresholds in discontinuous fuel beds. *International Journal of Wildland Fire*. 19: 163–170.
- Flannigan, M.D.; Stocks, B.J.; Wotton, B.M. 2000.** Climate change and forest fires. *Science of the total environment*. 262: 221–229.
- Fons, W.L. 1946.** Analysis of fire spread in light forest fuels. *Journal of Agricultural Research*. 72: 93–121.
- Fosberg, M.A. 1970.** Drying rates of heartwood below fiber saturation. *Forest Science*. 16: 57–63.
- Fosberg, M.A.; Rothermel, R.C.; Andrews, P.L. 1981.** Moisture content calculations for 1000-hour timelag fuels. *Forest Science*. 27: 19–26.
- Garcia, M.; Danson, F.M.; Riano, D.; Chuvieco, E.; Ramirez, F.A.; Bandugula, V. 2011.** Terrestrial laser scanning to estimate plot-level forest canopy fuel properties. *International Journal of Applied Earth Observation and Geoinformation*. 13: 636–645.
- Gisborne, H.T. 1933.** The wood cylinder method of measuring forest inflammability. *Journal of Forestry*. 31: 673–679.
- Grace, J.; Berninger, F.; Nagy, L. 2002.** Impacts of climate change on the tree line. *Annals of Botany*. 90: 537–544.
- Habeck, J.R.; Mutch, R.W. 1973.** Fire-dependent forests in the northern Rocky Mountains. *Quaternary Research*. 3: 408–424.
- Hanson, J.J.; Lorimer, C.G.; Halpin, C.R. 2011.** Predicting long-term sapling dynamics and canopy recruitment in northern hardwood forests. *Canadian Journal of Forest Research*. 41: 903–919.
- Hawley, L.F. 1926.** Theoretical considerations regarding factors which influence forest fires. *Journal of Forestry*. 25: 756–763.
- Heyerdahl, E.K.; Brubaker, L.B.; Agee, J.K. 2001.** Spatial controls of historical fire regimes: a multiscale example from the Interior West, USA. *Ecology*. 82: 660–678.
- Higgins, R.W.; Silva, V.B.S.; Shi, W.; Larson, J. 2007.** Relationships between climate variability and fluctuations in daily precipitation over the United States. *Journal of Climate*. 20: 3561–3579.
- Hoffman, C.; Morgan, P.; Mell, W.; Parsons, R.; Strand, E.; Cook, S. 2012.** Numerical simulation of crown fire hazard immediately after bark beetle-caused mortality in lodgepole pine forests. *Forest Science*. 58(2): 178–188.
- Iverson, L.R.; Prasad, A.M. 2002.** Potential redistribution of tree species habitat under five climate change scenarios in the eastern US. *Forest Ecology and Management*. 155: 205–222.
- Jenkins, M.J.; Hebertson, E.; Page, W.; Jorgensen, C.A. 2008.** Bark beetles, fuels, fires and implications for forest management in the Intermountain West. *Forest Ecology and Management*. 254: 16–34.
- Jenkins, M.J.; Page, W.G.; Hebertson, E.G.; Alexander, M.E. 2012.** Fuels and fire behavior dynamics in bark beetle-attacked forests in Western North America and implications for fire management. *Forest Ecology and Management*. 275: 23–34.
- Johnson, E.A.; Miyanishi, K.; Bridge, S.R.J. 2001.** Wildfire regime in the boreal forest and the idea of suppression and fuel buildup. *Conservation Biology*. 15: 1554–1557.
- Jolly, W.M.; Dobbertin, M.; Reichstein, M.; Zimmermann, N. 2005.** Divergent vegetation growth responses to the 2003 heat wave in the Swiss Alps. *Geophysical Research Letters*. 109: doi: 10.1029/2004JD004959.

- Jolly, W.M.; Parsons, R.A.; Hadlow, A.M.; Cohn, G. M.; McAllister, S.S.; Popp, J.B.; Hubbard, R.M.; Negrón, J.F. 2012.** Relationships between moisture, chemistry, and ignition of *Pinus contorta* needles during the early stages of mountain pine beetle attack. *Forest Ecology and Management*. 269: 52–59.
- Keane, R.E.; Reinhardt, E.D.; Scott, J.; Gray, K.; Reardon, J. 2005.** Estimating forest canopy bulk density using six indirect methods. *Canadian Journal of Forest Research*. 35: 724–739.
- Keeley, J.E.; Fotheringham, C.J.; Morais, M. 1999.** Reexamining fire suppression impacts on brushland fire regimes. *Science*. 284: 1829.
- Kerns, B.K.; Walter, G.T.; Christine G.N. 2006.** Season and severity of prescribed burn in ponderosa pine forests: implications for understory native and exotic plants. *Ecoscience*. 13.1: 44–55.
- Kuljian, H.; Varner, J.M. 2010.** The effects of sudden oak death on foliar moisture content and crown fire potential in tanoak. *Forest Ecology and Management*. 259: 2103–2110.
- Landsberg, J.J.; James, G.B. 1971.** Wind profiles in plant canopies: studies on an analytical model. *Journal of Applied Ecology*. 8: 729–741.
- Latif, M.; Anderson, D.; Barnett, T.; Cane, M.; Kleeman, R.; Leetmaa, A.; O'Brien, J.; Rosati, A.; Schneider, E. 1998.** A review of the predictability and prediction of ENSO. *Journal of Geophysical Research*. 103: 375–314.
- Lefsky, M.A.; Cohen, W.B.; Acker, S.A.; Parker, G.G.; Spies, T.A.; Harding, D. 1999.** Lidar remote sensing of the canopy structure and biophysical properties of Douglas-fir western hemlock forests. *Remote Sensing of Environment*. 70: 339–361.
- Linn, R.; Reisner, J.; Colman, J.J.; Winterkamp, J. 2002.** Studying wildfire behavior using FIRETEC. *International Journal of Wildland Fire*. 11: 233–246.
- Linn, R.; Winterkamp, J.; Colman, J.J.; Edminster, C.; Bailey, J.D. 2005.** Modeling interactions between fire and atmosphere in discrete element fuel beds. *International Journal of Wildland Fire*. 14: 37–48.
- Linn, R.R.; Harlow, F.H. 1997.** FIRETEC: a transport description of wildfire behavior. In: *Proceedings of the second symposium on fire and forest meteorology*. American Meteorological Society: 14–19.
- Little, S.; Forman, R.T.T. 1998.** Fire and plant succession in the New Jersey Pine Barrens. In: Forman, R.T.T., ed. *Pine Barrens: ecosystem and landscape*. New York, Academic Press. 297–314.
- Loope, L.; Duever, M.; Herndon, A.; Snyder, J.; Jansen, D. 1994.** Hurricane impact on uplands and freshwater swamp forest. *BioScience*. 44: 238–246.
- Lunan, J.S.; Habeck, J.R. 1973.** The effects of fire exclusion on ponderosa pine communities in Glacier National Park, Montana. *Canadian Journal of Forest Research*. 3: 574–579.
- Lutes, D.C.; Keane, R.E.; Caratti, J.F.; Key, C.H.; Benson, N.C.; Sutherland, S.; Gangi, L.J. 2006.** FIREMON: fire effects monitoring and inventory system. [CD-ROM]. Gen. Tech. Rep. RMRS-GTR-164-CD. Fort Collins, CO: U.S. Department of Agriculture, Forest Service, Rocky Mountain Research Station.
- MacDonald, G.M.; Velichko, A.A.; Kremenetski, C.V.; Borisova, O.K.; Goleva, A.A.; Andreev, A.A.; Cwynar, L.C.; Riding, R.T.; Forman, S.L.; Edwards, T.W.D. 2000.** Holocene treeline history and climate change across northern Eurasia. *Quaternary Research*. 53: 302–311.
- Mack, M.C.; D'Antonio, C.M. 1998.** Impacts of biological invasions on disturbance regimes. *Trends in Ecology and Evolution*. 13: 195–198.
- Mell, W.; Maranghides, A.; McDermott, R.; Manzello, S. 2009.** Numerical simulation and experiments of burning douglas fir trees. *Combustion and Flame*. 156: 2023–2041.

- Mell, W.E.; Manzello, S.L.; Maranghides, A. 2006.** Numerical modeling of fire spread through trees and shrubs. *Forest Ecology and Management*. 234: 15.
- Merrill, A.L.; Watt, B.K. 1973.** Energy value of foods: basis and derivation. *Agric. Handb. No. 74*. Washington, DC: U.S. Department of Agriculture.
- Miles, P.D.; Brand, G.J.; Alerich, C.L.; Bednar, L.F.; Woudenberg, S.W.; Glover, J.F.; Ezzell, E.N. 2001.** The forest inventory and analysis database: database description and users manual version 1.0. Gen. Tech. Rep. GTR-NC-218. St. Paul, MN: U.S. Department of Agriculture, Forest Service, North Central Research Station. 130 p. <http://www.fi.a.fs.fed.us/>.
- Miller, C.; Urban, D.L. 2000.** Connectivity of forest fuels and surface fire regimes. *Landscape Ecology*. 15: 145–154.
- Morvan, D.; Dupuy, J.L. 2001.** Modeling of fire spread through a forest fuel bed using a multiphase formulation. *Combustion and Flame*. 127: 1981–1994.
- Mutch, R.W. 1970.** Wildland fires and ecosystems—a hypothesis. *Ecology*. 51: 1046–1051.
- Myers, R.K.; van Lear, D.H. 1998.** Hurricane-fire interactions in coastal forests of the south: a review and hypothesis. *Forest Ecology and Management*. 103: 265–276.
- Nelson, R.M., Jr. 2001.** Water relations of forest fuels. In: Johnson, E.A.; Miyanishi, K., eds. *Forest fires: behavior and ecological effects*. San Diego, CA: Academic Press: 79–149.
- National Wildfire Coordinating Group [NWCG]. 1997.** Historical wildland firefighter fatalities (1910-1996). PMS-822. Boise, ID: National Interagency Fire Center. http://www.nwcg.gov/pms/docs/fat_pdf.pdf. (5 March 2014).
- National Wildfire Coordinating Group [NWCG]. 2011.** Glossary of wildland fire terminology. PMS 205. Boise, ID: National Interagency Fire Center. <http://www.nwcg.gov/pms/pubs/glossary/e.htm>. (5 March 2014).
- Ohmann, J.L.; Spies, T.A. 1998.** Regional gradient analysis and spatial pattern of woody plant communities of Oregon forests. *Ecological Monographs*. 68: 151–182.
- Oliver, C.D. 1980.** Even-aged development of mixed-species stands. *Journal of Forestry*. 78: 201–203.
- Ottmar, R.D.; Prichard, S.J.; Anderson, G.A. 2005.** Consume 3.0. <http://www.fs.fed.us/pnw/fera/research/smoke/consume/index.shtml>. (March 5, 2014).
- Ottmar, R.D.; Sandberg, D.V.; Riccardi, C.L.; Prichard, S.J. 2007.** An overview of the Fuel Characteristic Classification System: quantifying, classifying and creating fuelbeds for resource planning. *Canadian Journal of Forest Research*. 37: 2383–2393.
- Owens, M.K.; Lin, C.-D.; Taylor, C.A.J.; Whisenant, S.G. 1998.** Seasonal patterns of plant flammability and monoterpenoid content in *Juniperus ashei*. *Journal of Chemical Ecology*. 24: 2115–2129.
- Pachauri, R.K.; Reinsinger, A., eds. 2007.** Climate change 2007: synthesis report. Contribution of working groups I, II and III to the fourth assessment report of the Intergovernmental Panel on Climate Change. Geneva, Switzerland: Intergovernmental Panel on Climate Change. 104 p.
- Page, W.G.; Jenkins, M.J. 2007a.** Mountain pine beetle-induced changes to selected lodgepole pine fuel complexes within the Intermountain Region. *Forest Science*. 53: 507–518.
- Page, W.G.; Jenkins, M.J. 2007b.** Predicted fire behavior in selected Mountain pine beetle-infested lodgepole pine. *Forest Science*. 53: 662–674.
- Parker, G.G.; Harding, D.J.; Berger, M.L. 2004.** A portable LIDAR system for rapid determination of forest canopy structure. *Journal of Applied Ecology*. 41: 755–767.
- Parsons, D.J.; DeBenedetti, S.H. 1979.** Impact of fire suppression on a mixed-conifer forest. *Forest Ecology and Management*. 2: 21–33.

- Parsons, R.A.; Mell, W.E.; McCauley, P. 2011.** Linking 3D spatial models of fuels and fire: effects of spatial heterogeneity on fire behavior. *Ecological Modelling*. 222: 679–691.
- Pellizzaro, G.; Duce, P.; Ventura, A.; Zara, P. 2007.** Seasonal variations of live moisture content and ignitability in shrubs of the Mediterranean Basin. *International Journal of Wildland Fire*. 16: 633–641.
- Philpot, C.W. 1965.** Diurnal fluctuation in moisture content of ponderosa pine and whiteleaf manzanita leaves. Res. Note PSW-RN-67. Berkeley, CA: U.S. Department of Agriculture, Forest Service, Pacific Southwest Research Station. 7 p.
- Philpot, C.W. 1970.** Influence of mineral content on the pyrolysis of plant materials. *Forest Science*. 16: 461–471.
- Pickett, B.M.; Isackson, C.; Wunder, R.; Fletcher, T.H.; Butler, B.W.; Weise, D.R. 2010.** Experimental measurements during combustion of moist individual foliage samples A. *International Journal of Wildland Fire*. 19: 153–162.
- Pyne, S.J.; Andrews, P.L.; Laven, R.D. 1996.** Introduction to wildland fire. Hoboken, NJ: John Wiley & Sons. 808 p.
- Raffa, K.F.; Aukema, B.H.; Bentz, B.J.; Carroll, A.L.; Hicke, J.A.; Turner, M.G.; Romme, W.H. 2008.** Cross-scale drivers of natural disturbances prone to anthropogenic amplification: the dynamics of bark beetle eruptions. *BioScience*. 58: 501–517.
- Raupach, M.R.; Finnigan, J.J.; Brunei, Y. 1996.** Coherent eddies and turbulence in vegetation canopies: the mixing-layer analogy. *Boundary-Layer Meteorology*. 78: 351–382.
- Reinhardt, E.D.; Crookston, N.L., tech. eds. 2003.** The fire and fuels extension to the forest vegetation simulator. Gen. Tech. Rep. RMRS-116. Ogden, UT: U.S. Department of Agriculture, Forest Service, Rocky Mountain Research Station. 209 p.
- Reinhardt, E.D.; Keane, R.E.; Brown, J.K. 1997.** First Order Fire Effects Model: FOFEM 4.0, user's guide. GTR-INT-344. Ogden, UT: U.S. Department of Agriculture, Forest Service, Intermountain Research Station. 65 p.
- Reinhardt, E.D.; Keane, R.E.; Calkin, D.E.; Cohen, J.D. 2008.** Objectives and considerations for wildland fuel treatment in forested ecosystems of the interior western United States. *Forest Ecology and Management*. 256: 1997–2006.
- Riccardi, C.L.; Prichard, S.J.; Sandberg, D.V.; Ottmar, R.D. 2007.** Quantifying physical characteristics of wildland fuels using the Fuel Characteristic Classification System. *Canadian Journal of Forest Research*. 37: 2413–2420.
- Rich, R.L.; Frelich, L.E.; Reich, P.B. 2007.** Wind-throw mortality in the southern boreal forest: effects of species, diameter and stand age. *Journal of Ecology*. 95: 1261–1273.
- Richards, L.W. 1940.** Effects of certain chemical attributes of vegetation on forest inflammability. *Journal of Agricultural Research*. 60: 833–838.
- Rollins, M.G.; Frame, C.K. 2006.** The LANDFIRE Prototype Project: nationally consistent and locally relevant geospatial data for wildland fire management. Gen. Tech. Rep. RMRS-GTR-175. Fort Collins, CO: U.S. Department of Agriculture, Forest Service, Rocky Mountain Research Station. 416 p.
- Rothermel, R.C. 1972.** A mathematical model for predicting fire spread in wildland fuels. Res. Pap. INT-115. Ogden, UT: U.S. Department of Agriculture, Forest Service, Intermountain Forest and Range Experiment Station. 40 p.
- Rothermel, R.C. 1991.** Predicting behavior and size of crown fires in the Northern Rocky Mountains. Res. Pap. INT-438. Ogden, UT: U.S. Department of Agriculture, Forest Service, Intermountain Research Station. 46 p.

- Ryu, S.R.; Chen, J.; Crow, T.R.; Saunders, S.C. 2004.** Available fuel dynamics in nine contrasting forest ecosystems in North America. *Environmental Management*. 33: 87–107.
- Sandberg, D.V. ; Riccardi, C.L.; Schaaf, M.D. 2007.** Fire potential rating for wildland fuelbeds using the Fuel Characteristic Classification System. *Journal of Forest Research*. 37: 2456–2463.
- Schar, C.; Vidale, P.L.; Luthi, D.; Frei, C.; Haberli, C.; Liniger, M.A.; Appenzeller, C. 2004.** The role of increasing temperature variability in European summer heatwaves. *Nature*. 427: 332–336.
- Schimmel, J.; Granström, A. 1997.** Fuel succession and fire behavior in the Swedish boreal forest. *Canadian Journal of Forest Research*. 27: 1207–1216.
- Scott, J.H. 1999.** NEXUS: a system for assessing crown fire hazard. *Fire Management Notes*. 59: 20–24.
- Scott, J.H.; Burgan, R.E. 2005.** Standard fire behavior fuel models: a comprehensive set for use with Rothermel's surface fire spread model. Gen. Tech. Rep. RMRS-GTR-153. Fort Collins, CO: U.S. Department of Agriculture, Forest Service, Rocky Mountain Research Station. 72 p.
- Scott, J.H.; Reinhardt, E.D. 2001.** Assessing crown fire potential by linking models of surface and crown fire behavior. Res. Pap. RMRS-RP-29. Fort Collins, CO: U.S. Department of Agriculture, Forest Service, Rocky Mountain Research Station. 59 p.
- Seidel, D.; Fleck, S.; Leuschner, C. 2012.** Analyzing forest canopies with ground-based laser scanning: a comparison with hemispherical photography. *Agricultural and Forest Meteorology*. 154-155: 1–8.
- Shafizadeh, F. 1968.** Pyrolysis and combustion of cellulosic materials. *Advances in Carbohydrate Chemistry*. 23.
- Simard, A.J. 1968.** The moisture content of forest fuels: a review of the basic concepts. *Forest Fire Research Institute*. 47 p.
- Simard, M.; Romme, W.H.; Griffin, J.M.; Turner, M.G. 2011.** Do mountain pine beetle outbreaks change the probability of active crown fire in lodgepole pine forests? *Ecological Monographs*. 81: 3–24.
- Stacey, G.R.; Belcher, R.E.; Wood, C.J.; Gardiner, B.A. 1994.** Wind flows and forces in a model spruce forest. *Boundary-Layer Meteorology*. 69: 311–334.
- Steen, H.K. 1963.** Relation between moisture content of fine fuels and relative humidity. PNW-4. Portland, OR: U.S. Department of Agriculture, Forest Service, Pacific Northwest Forest Service. 6 p.
- Sussott, R.A.; DeGroot, W.F.; Shafizadeh, F. 1975.** Heat content of natural fuels. *Journal of Fire and Flammability*. 6: 311–325.
- Tanskanen, H.; Venäläinen, A.; Puttonen, P.; Granström, A. 2005.** Impact of stand structure on surface fire ignition potential in *Picea abies* and *Pinus sylvestris* forests in southern Finland. *Canadian Journal of Forest Research*. 35: 410–420.
- Tkacz, B.; Moody, B.; Castillo, J.V.; Fenn, M.E. 2008.** Forest health conditions in North America. *Environmental Pollution*. 155: 409–425.
- Valachovic, Y.S.; Lee, C.A.; Scanlon, H.; Varner, J.M.; Glebocki, R.; Graham, B.D.; Rizzo, D.M. 2011.** Sudden oak death-caused changes to surface fuel loading and potential fire behavior in Douglas-fir-tanoak forests. *Forest Ecology and Management*. 261: 1973–1986.
- Van Mantgem, P.J.; Stephenson, N.L.; Byrne, J.C.; Daniels, L.D.; Franklin, J.F.; Fulè, P.Z.; Harmon, M.E.; Larson, A.J.; Smith, J.M.; Taylor, A.H. 2009.** Widespread increase of tree mortality rates in the western United States. *Science*. 323: 521.
- Van Wagner, C.E. 1977.** Conditions for the start and spread of crown fire. *Canadian Journal of Forest Research*. 7: 23–24.
- Van Wagner, C.E. 1993.** Prediction of crown fire behavior in two stands of jack pine. *Canadian Journal of Forest Research*. 23: 442–449.

- Viedma, O.; Angeler, D.G.; Moreno, J.M. 2009.** Landscape structural features control fire size in a Mediterranean forested area of central Spain. *International Journal of Wildland Fire*. 18: 575–583.
- Vitousek, P.M.; D'Antonio, C.M.; Loope, L.L.; Rejmanek, M.; Westbrooks, R. 1997.** Introduced species: a significant component of human-caused global change. *New Zealand Journal of Ecology*. 21: 1–16.
- Waring, R.H.; Running, S.W. 1998.** Forest ecosystems: analysis at multiple scales. San Diego, CA: Academic Press, Inc. 370 p.
- Werth, P.A.; Potter, B.E.; Clements, C.B.; Finney, M.A.; Goodrick, S.L.; Alexander, M.E.; Cruz, M.G.; Forthofer, J.A.; McAllister, S.S. 2011.** Synthesis of knowledge of extreme fire behavior: volume 1 for fire managers. Gen. Tech. Rep. PNW-GTR-854. Portland, OR: U.S. Department of Agriculture, Forest Service, Pacific Northwest Research Station. 144 p.
- Westerling, A.L.; Gershunov, A.; Brown, T.J.; Cayan, D.R.; Dettinger, M.D. 2003.** Climate and wildfire in the western United States. *Bulletin of the American Meteorological Society*. 84: 595–604.
- Westerling, A.L.; Hidalgo, H.G.; Cayan, D.R.; Swetnam, T.W. 2006.** Warming and earlier spring increase western U.S. forest wildfire activity. *Science*. 313: 940–943.
- Whittaker, R.H. 1967.** Gradient analysis of vegetation. *Biological Reviews*. 42: 207–264.
- Williamson, N.M.; Agee, J.K. 2002.** Heat content variation of interior Pacific Northwest conifer foliage. *International Journal of Wildland Fire*. 11: 91–94.
- Wittinger, W.T.; Pengelly, W.L.; Peek, J.M. 1977.** A 20-year record of shrub succession in logged areas in the cedar-hemlock zone of northern Idaho. *Northwest Science*. 51.
- Woodall, C.W.; Nagel, L.M. 2007.** Downed woody fuel loading dynamics of a large-scale blowdown in northern Minnesota, U.S.A. *Forest Ecology and Management*. 247: 194–199.
- Xanthopoulos, G.; Wakimoto, R.H. 1993.** A time to ignition-temperature-moisture relationship for branches of three western conifers. *Canadian Journal of Forest Research*. 23: 253–258.

Chapter 5: Fire Interactions and Mass Fires

Mark A. Finney¹ and Sara S. McAllister²

Introduction

Some interactions of wildland fires are experienced routinely under field conditions. Firefighters and prescribed fire personnel see flames tilting toward adjacent ignition points or fire edges, particularly as the sources advance closer together (Martin and Dell 1978, Rothermel 1984). In the extreme case, interactions occurring when large areas are ignited and burning simultaneously are described as mass fires, area fires, or “fire storms” (Countryman 1964). Hundreds or thousands of individual fires may interact over an area and exhibit some “unified” behavior. Such fires are generally described as having such strong indrafts that outward propagation is minimal. They have extremely tall convection columns or smoke plumes and burn for long durations until all the fuel within their perimeter is consumed. Good reviews of mass or large area fires can be found in Williams (1982), Pitts (1991), and Heskestad (1998). Mass fires were responsible for tremendous burning rates and tornado-strength winds (Carrier et al. 1985) witnessed after the fire bombings of cities in Germany and Japan during World War II (Hewitt 1983, Schmalz 1992) and have been studied mainly in relation to consequences of nuclear attacks (Balwin and North 1967; Chandler 1963; Countryman 1964, 1965, 1969; Eggleston 1968; German 1968; Hewitt 1983; Larson et al. 1982; Larson and Small 1982a, 1982b; Lee 1969a, 1969b; Lommasson et al. 1967, 1968; Nielsen 1970; Nielsen et al. 1963; Parker 1967; Penner et al. 1986; Pryor and Yuill 1966; Quintiere 1993; Sanderlin et al. 1981; Wood et al. 1971). Many of these studies were through “Project Flambeau,” a joint effort between the U.S. Office of Civil Defense, Defense Atomic Support Agency and the U.S. Department of Agriculture Forest Service in

the mid-1960s. These fires were designed to mimic a suburban fire. Each square fuel bed was constructed with a mixture of pinyon pine and juniper (see “Common and Scientific Names” section) and was approximately the same size and fuel load as a typical suburban house (185.8 m² and about 18 000 kg of fuel). The spacing between fuel beds was either 7.6 m or 35.1 m and fire sizes were 2, 6, 12, and 20 ha. Airflow velocities and temperatures were measured inside and just outside the fire area along with thermal radiation just outside the fire area, oxygen and carbon dioxide concentrations inside the fire area, and the mass loss rate of the fuel beds (Countryman 1964, 1965, 1969).

Wildland fire interactions are intentionally manipulated for ignition or firing operations (see figs. 5-1 and 5-2) to orient spread directions (Johansen 1987), use indrafts for backfire operations (Miralles et al. 2010), increase the development of convection columns on prescribed fires through center-firing techniques (Martin and Dell 1978), and limit spread and intensity with spot fire ignitions (Johansen 1984, Luke and McArthur 1978, Weatherspoon et al. 1989). Rapid increases in fire growth and energy release—termed “blowup”—are sometimes associated with fire interactions (Arnold and Buck 1954). Yet, despite the common usage and practical familiarity with interactions that fire personnel often acquire, very little quantitative information exists about the physical processes involved and there are no operational models that can predict them. By comparison to other fire behavior characteristics, such as fire spread rates, fire interactions at any scale have been subject to limited study.

In this review, we endeavored to obtain literature from many sources, including wildland fire, and structural fire, as well as combustion engineering and fluid dynamics, to cover the range of research on fire-fire interactions and the state of knowledge. Our search revealed that the topic of fire interactions overlaps considerably with other fire behaviors that are distinguished individually, such as vortices and terrain effects. These behaviors will be mentioned when

¹ **Mark A. Finney** is a research forester, U.S. Department of Agriculture, Forest Service, Missoula Fire Sciences Laboratory, 5775 US West Highway 10, Missoula, MT 59808.

² **Sara S. McAllister** is a research mechanical engineer, U.S. Department of Agriculture, Forest Service, Missoula Fire Sciences Laboratory, 5775 US West Highway 10, Missoula, MT 59808.

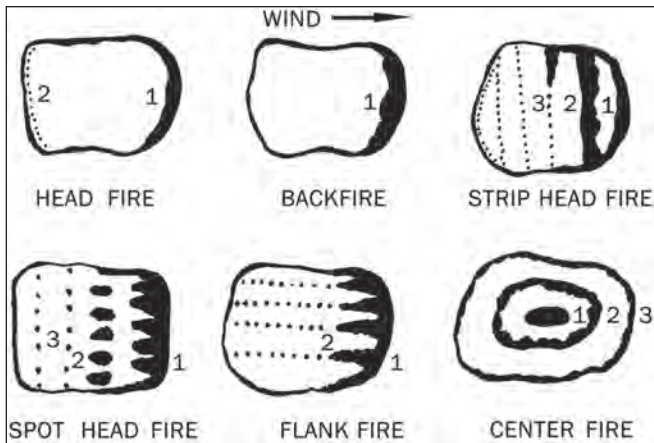

Figure 5-1—Prescribed fire ignition patterns designed to restrict or enhance fire front interactions (from Martin and Dell 1978).

appropriate, but their full discussion is beyond the scope of this review.

Background: Time-Dependent Fire Behaviors

For a constant set of environmental conditions, fire behavior is known to change with time. These changes are not expressly considered interactions, but spread and intensity changes within individual fires are also affected during interaction among fires and may contribute to later development of interactions. Thus, such behaviors provide useful background material for discussion of fire-fire interactions, although studies of fire acceleration have not directly addressed interactions of multiple fires. Many of the time-dependent changes in fire behavior are associated with fire growth or expansion in two dimensions. Changes are observed in spread rates (acceleration), frontal geometry (width, curvature), and heat transfer indicated by the orientation and size of flames. These fire characteristics are interrelated with spread processes, and the literature does not discern the causes of observable features as distinct from their probable effects.

Fire acceleration

Fire acceleration is defined as the time-dependent changes in spread and intensity occurring under constant weather and uniform fuel conditions. The notion of acceleration is implicitly applied to fires that are already capable of

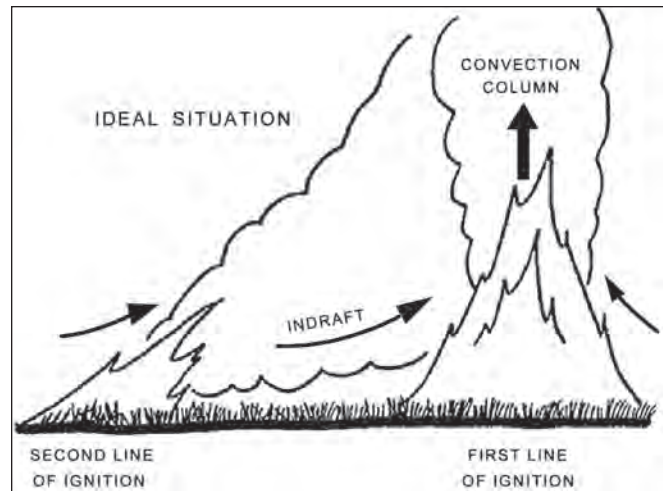

Figure 5-2—Indrafting and flame response of sequential line fires in prescribed burning (from Rothermel 1984).

spreading as compared to combinations of threshold conditions where spread only occurs above some limit. Various mathematical representations of acceleration (fig. 5-3) have been proposed from a theoretical standpoint that express spread rate from a point-source fire as a negative exponential function of time (Cheney 1981, Cheney and Bary 1969). Parameters of these equations were fit to empirical data from wind tunnel experiments by McAlpine and Wakimoto (1991). These functions tend toward a final equilibrium rate and are, thus, commonly communicated in terms of the time to reach some fixed fraction of equilibrium (e.g., 90 percent). A similar result was developed by Weber (1989), who represented acceleration of fires expanding as a circle from a point ignition and depended on the curvature of the fire front.

Studies of acceleration typically report time elapsed from ignition to a near-steady spread rate. Values of 20 to 30 min for point-source ignitions in slash fuels for prescribed fire conditions (McRae 1999) and in pine litter and feather moss (Kucuk et al. 2007) have been reported. Wind-driven grass fires in Australia (Albini 1982) showed large variation in acceleration times (about 6 min under slow wind conditions to over 45 min with faster winds) and a strong dependency on the width of the fire front. Wind tunnel burns of shallow (8 cm deep) pine needle and excelsior beds suggested time to equilibrium of only a few minutes (McAlpine and Wakimoto 1991) and largely independent of

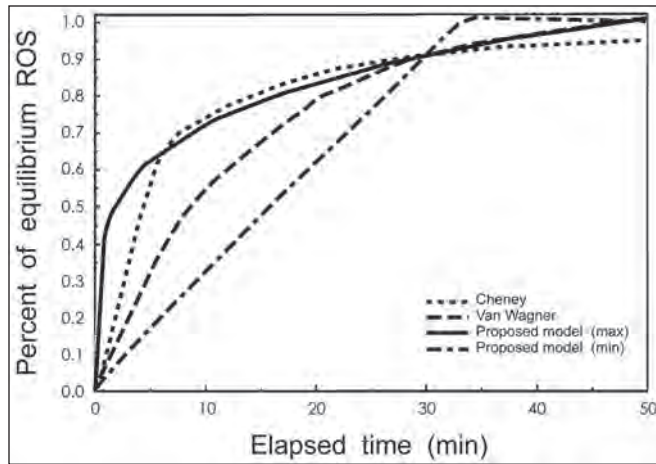

Figure 5-3—Theoretical fire spread rate acceleration curves from point-source ignitions show asymptotic increase in spread rate over time toward an equilibrium (from McAlpine and Wakimoto 1991). ROS = rate of spread.

windspeed. Data from point ignitions in pine needle litter reported by Curry and Fons (1938) suggested windspeed affected acceleration rate (increased time to equilibrium) as well as a final spread rate. Windspeed may also affect acceleration times for conflagrations involving structures at urban densities. Chandler et al. (1963) referenced much longer time estimates than for wildland fuels, including 1 hr to achieve near-steady spread rates with windspeed up to 7 m/s, 2 h for winds to 18 m/s and possibly much longer times for stronger winds. A long acceleration period, exceeding the 36-min observation time, was described for line ignitions in heavy fuel loadings associated with felled eucalyptus slash (McArthur 1969a). By contrast, rapid acceleration to near-steady burning after line ignition was reported for experimental crown fires in jack pine forests (Stocks 1989). A theoretical analysis by Albin (1982) suggests that line ignitions in surface fuels could accelerate very rapidly, initially overshooting the steady rate, but then slow and exhibit damped oscillations toward the steady value as the increasing vertical buoyancy of the combustion zone offsets horizontal wind force. From the existing literature, it is not clear what influences the various factors of fuel loading, fuel sizes, burning duration, and final spread rates have on

acceleration time, nor more complicated interactions among multiple flame zones or heat sources.

In addition, acceleration of fires can occur when air inflow is asymmetrically restricted by surface topography, either in canyons (Viegas and Pita 2004), or inclined channels (Woodburn and Drysdale 1998) and slopes (Dold and Zinoviev 2009, Wu et al. 2000). Detailed treatment of these important fire-topographic interactions, however, is beyond the scope of this review of fire-fire interactions.

Length of Fire Front

Fire acceleration and final spread rate appear to be dependent on fire size. Fires accelerate slowly from point-ignition sources (Cheney and Gould 1995, McAlpine and Wakimoto 1991, McRae 1999) relative to line-source ignitions (Cheney and Gould 1995, Johansen 1987). At the small scale of laboratory stick arrays, fuel bed width and proportion of edge on the curvature of the head fire had significant effects on spread rate (Fendell and Wolff 2001). In wind-driven grass fires, fire spread rates were found to be dependent on the length of the ignition for lines shorter than 50 to 75 m (Cheney and Gould 1995) and required longer acceleration times for higher winds (fig. 5-4). Experiments and modeling by Wotton et al. (1999) for fires in red pine litter, however, showed no increase in radiation from flames for ignition lines longer than about 2 m and no effect of line width on spread rate beyond about 1 m. Dold et al. (2006) offered an explanation for fire size effect on forward spread rate. As fires expand in two dimensions, the distance between the fire edges increases, meaning that buoyancy-induced inflow along segments of flaming front comes from a wider area. This allows ambient winds from behind the front to penetrate to the heading portion of the flame zone. Such effects on narrow combustion zones of expanding fires are presumably different than for mass fires or large-area ignitions, which create indrafts from all directions (Baum and McCaffrey 1989, Smith et al. 1975) and strong buoyancy-driven convection may deflect ambient airflow around the column (Countryman 1964).

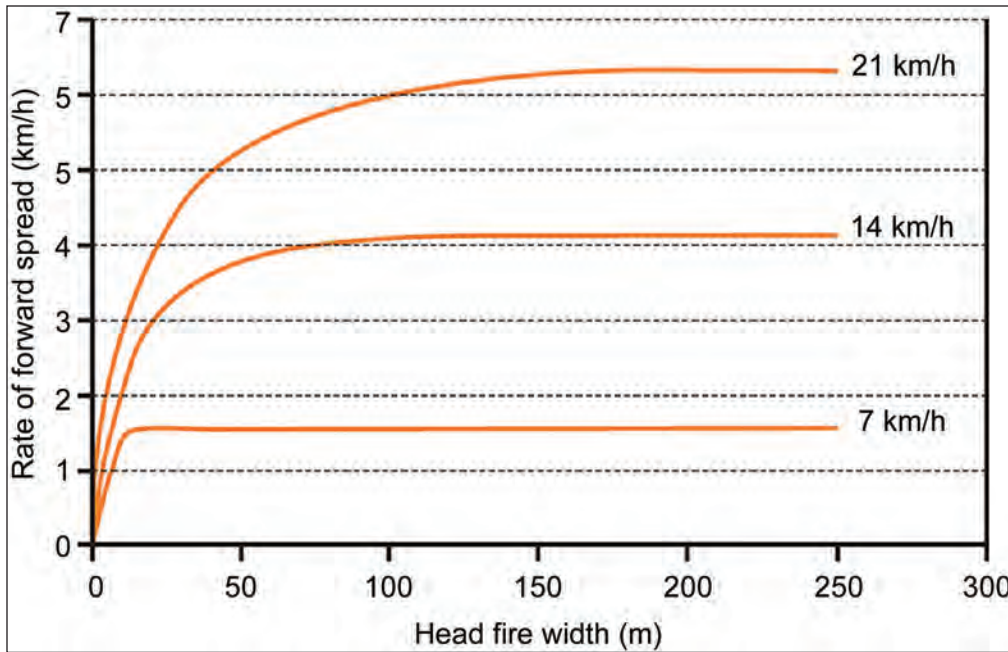

Figure 5-4—Fire spread rates in grass fuels were found to increase with the width of head fires and depend on the final spread rates determined by windspeed (from Tolhurst and Cheney 1999).

Flame Tilt

Flame angle orientation relative to the unburned fuel is related to acceleration and is affected by fire size and stage of growth. Flames can tilt owing to wind, slope, or the interaction with other fires. Flames tilted away from the direction of spread are referred to as backing fires, and flames tilting toward the direction of spread are referred to as heading fires. Flames tilt toward the interior of the burned area in small fires or point-source fires, producing backing spread (Fendell and Wolff 2001, Luke and McArthur 1978, Tolhurst and Cheney 1999). Spread rate of backing fires spreading downslope has been shown to be only weakly diminished as slope increases (Van Wagner 1988) and little affected by wind (Beaufait 1965, McAlpine and Wakimoto 1991). Backing fires have been reported to increase fuel consumption and residence times. As fires grow larger, backing fire remains only at the rear of the perimeter (upwind or downslope) and flames for the heading portion of the fire tilt toward the unburned fuel. The very large differences in spread rate and intensity between backing and heading fires (and flanking fires) can be estimated assuming elliptical fire shapes (Catchpole et al. 1982). Numerous studies of flame tilt angle in a wildland fuel bed on flat terrain in wind

have consistently found a strong relationship to the Froude number calculated from ratios of windspeed to intensity or flame length (Albini 1981, 1982; Nelson and Adkins 1986; Weise and Bigging 1996). Similar experimental results were found using liquid pool fires (Martin et al. 1991, Pipkin and Sliepcevich 1964, Welker and Sliepcevich 1966, Welker et al. 1965) and were explained as the counteraction of upward buoyant forces by crossflow, including flame trailing (lateral deflection of combustion products and flames) with high windspeeds. Recent numerical modeling (Nmira et al. 2010) has also reported Froude number relationships for both line-source and point-source simulated fires. Although slope effects were deemed significant (Weise and Bigging 1996), they are not accounted for in such formulations. When fires are in proximity, the interaction between them can change the flame tilt angle and rates of spread (Pitts 1991, Rios 1966, Welker et al. 1965). In these cases, the flame tilt angles can be correlated with a modified Froude number that includes the separation distance of the fires (Pitts 1991, Rios 1966, Welker et al. 1965). In the case of no wind, a modified Grashof number is used (Gebhart et al. 1976, Pera and Gebhart 1975) to describe the flame tilt purely owing to flame interaction.

Spread Thresholds

Thresholds describe a point of near-instantaneous acceleration that delineates when fire will and will not spread. Threshold-crossing for fire spread has been documented for many discontinuous fuel types including grasses (Marsden-Smedly et al. 2001), shrubs (Barrows et al. 1991, Bradstock and Gill 1993, Brown 1982, Weise et al. 2005), and trees (Bruner and Klebenow 1979, Van Wagner 1977). Laboratory-scale fires reveal similar spread thresholds in arrays of small sticks (Beer 1995, Vogel and Williams 1970, Weber 1990) and taller beds of excelsior (Finney et al. 2010). These studies reveal threshold dependencies on multiple environmental, fuel, and fire variables, such as windspeed, fuel moisture, slope, horizontal fuel gap dimensions, fuel bed depth, fuel combustion rate, and flame size. Chandler (1963) proposed combinations of ranges of windspeed, humidity, and rainfall by fuel type to define spread thresholds for significant growth of large fires. Recent studies of fire spread sustainability provide empirical evidence on the importance of fuel moisture, wind, and fuel loading (Beverly and Wotton 1997, Leonard 2009). As described in later sections of this chapter, fire interactions exert strong influences over many of these same environmental and fire variables, and thus, may elicit threshold-crossing spread for fires burning in discontinuous fuels.

Conditions Where Fire Interactions Occur

Interactions are possible when many separate fires grow together or multiple segments of a single continuous fire are oriented in proximity. In natural wildland fires, multiple fronts often occur because of spotting from a single main fire. Spot fires are relatively common under dry and windy conditions and even long-distance spotting contributes to fire movement (Anderson 1968). But massive deposition of firebrands at relatively short distances from the fire front (a few kilometers) can substantially increase spread rate and create simultaneous area ignition (Cheney and Bary 1969). On wildfires, Cheney and Bary observed that the highest concentration of fire brands fell within a fan-shaped zone about 9 degrees in angle on either side of the primary wind direction and theorized that mass fire behavior could

be achieved for certain unspecified combinations of fire brand density and acceleration time for individual ignitions. Johansen (1984) made similar observations for spot ignition patterns on prescribed burns where higher spot densities increased the numbers and frequencies of junction or merger zones. The increase in intensity at such junction zones has been documented empirically (Johansen 1984, McRae et al. 2005) and modeled (Morvan et al. 2009) leading to recommendations for wide separation of ignitions (Marsden-Smedley 2009, Tolhurst and Cheney 1999) unless area ignition is desired (Taylor et al. 1973). Mass ember deposition and area ignition has been documented by McArthur (1969b) for Tasmanian fires, where it resulted in near-simultaneous ignition of hillsides. A similar process was proposed for the Air Force Bomb Range Fire (Wade and Ward 1973), periodically causing area ignition ahead of the main front and vertical development of a convection column. Modeling by Weihs and Small (1986) showed that interactions between large mass fires can even cause these typically nonspreading fires to propagate toward one another.

How close together fires must be before flames visibly interact and subsequently merge is not clear. There have been many empirically derived merging criteria in the literature. Correlations exist for the critical parameters for both flame interaction (Baldwin 1968, Liu et al. 2007, Sugawa and Takahashi 1993) and merging (Delichatsios 2007, Fukuda et al. 2004, Putnam and Speich 1963, Wood et al. 1971). These correlations take many forms—some define a critical ratio between the fire spacing and fire diameter (Sugawa and Takahashi 1993, Wood et al. 1971) or flame height (Baldwin 1968, Delichatsios 2007, Liu et al. 2007), some define a critical ratio between the flame height and fire diameter (Wood et al. 1971), and some define a critical dimensionless heat release rate (Fukuda et al. 2004, Putnam and Speich 1963). Upon close examination, however, it becomes clear that fire spacing, fire diameter, flame height, and dimensionless heat release rate have interdependencies, and, thus, these different correlations are not necessarily contradictory. The discussion here will focus on the relations between spacing, diameter, and flame height because they are the most intuitive.

Using both gas diffusion burners and pool fires, Sugawa and Takahashi (1993) reported that flames begin to interact when the ratio of the spacing distance to the fire diameter is less than four. In other words, flames can interact, here defined as visually tilting, over distances four times their diameter. Baldwin (1968) considered the onset of flame interaction in terms of flame height. Flames were considered to be interacting if the flame heights increased more than 10 percent above the independent flame height. Using square and round gas burners, wood cribs, and large timber yard fires, Baldwin (1968) (and Baldwin 1966, Baldwin et al. 1964, Thomas 1968) correlated experimental data over a wide range of scales and configurations found in the literature and determined that the flames would interact if the spacing was less than 0.22 times the flame length. For a characteristic dimension D and height L , this correlation holds for $1 < L/D < 300$. Liu et al. (2007) also found the same dependency but with a slightly different constant of proportionality for merging of round pool fires. In their experiments, flame merging was likely to occur when closer than 0.29 to 0.34 times the merged flame length. Delichatsios (2007) also found that flames began to merge at spacing less than 0.33 times the actual flame length for gaseous burners. The discrepancy in these constants may be due to different definitions of flame interaction (tilting versus change in flame height) and flame merging (using completely merged flame height versus actual flame height), different fuels, and possibly uncertainty of measuring flame dimensions. In comparing the results of the Project Flambeau fires to those using a sand-filled pan burner, Wood et al. (1971) reported that flames merged if the flame height was at least half of the fire diameter. Heskestad (1998) clarified that this occurs when the nondimensional group $N \sim Q^2/D^5$ is near 10^{-5} (Q is the heat release rate and D is the fire diameter). Clearly there is no definitive criterion for when flames begin to interact and merge, and these relations will remain qualitative guidelines until there is some sort of unifying theory.

An opposing effect may occur with area fires over large homogenous fuel beds (small flame height compared to fire diameter). For a sufficiently large fuel bed, it may be impossible for a continuous flame to exist over the entire

bed. Instead of one continuous flame, the fire may break up into many distributed flamelets (Countryman 1969, Heskestad 1991, Wood et al. 1971). Heskestad (1991) showed that the breakup of continuous flames occurs when the nondimensional group $N \sim Q^2/D^5$ is near 10^{-6} . The convection column for these cases has been described as having two modes: Bénard cell convection near the surface, which then merges and transitions to a more organized convective plume (Fosberg 1967).

Specific Effects of Fire Interaction

Studies of fire interactions involve specific types of behavior of the combustion and observable fire characteristics. Most of the research on these behaviors comes from laboratory experiments with artificial fuel sources and attempts to isolate the particular response of interest.

Burning Rate

When fire fronts are close enough to interact and merge, such as in a mass fire, the mass of fuel burned as a function of time, or burning rate, of the fire can change dramatically. Much of the research on fire interactions has been done using gas burners with a fixed burning rate, but there has been some work on the interaction of flames over liquid pool fires and wood crib fires. Although the geometry and heat transfer mechanisms inside the fuel bed are different, liquid pool fires are much like fires burning over solid fuel in that the heat transfer from the fire back to the fuel controls the burning rate. In contrast, the burning rate of a gas burner is controlled by using a fixed fuel supply rate. Results from pool and crib fire experiments can often be extended to larger fuel beds using appropriate scaling laws (Emori and Saito 1983).

The experiments by Huffman et al. (1969) clearly revealed the effect of spacing on the burning rate of pool fires. In this work, the burning rate of an array of liquid pools was measured while keeping a constant fuel depth and varying the number of pools, pool diameter, fuel, and pool separation distance. In general, the burning rate of each individual pool burner increases as the burners are brought closer together and the flames began to interact. In particular, the pools in the middle of the array show a very

dramatic increase. For example, figure 5-5 shows that the burning rate of 4-in diameter pools of cyclohexane experienced over a 400-percent increase in burning rate when the separation distance was halved. At the onset of flame merging, the burning rate is at its maximum. As the flames merge, the burning rate decreases as the separation distance continues to decrease. In the limit of zero separation distance, however, the burning rate of the individual fires is still larger than if they were burning independently with no interaction effects. These trends were also seen by Grumer and Strasser (1965) with solid fuel beds.

Kamikawa et al. (2005) studied the effect of flame merging on heat release rates (heat released per time). Heat release rate is calculated by multiplying the burning rate (mass of fuel burned per time) by the heat of reaction (heat released per mass of fuel burned). However, the heat of reaction is dependent on the fuel and the mixture ratio of fuel to air. In large fire arrays, the inner regions of the array typically experience a shortage of air. Without sufficient air, the fuel cannot completely react and release the full potential heat; i.e., the combustion efficiency is low and less heat

is released per mass of fuel. Not surprisingly, Kamikawa et al. saw the same trend with heat release rates as Huffman et al. (1969) with burning rates. When the flames are merged, the heat release rate increases with separation distance. As the burners are moved farther apart, more air can penetrate into the inner regions of the array. More air entrainment means greater combustion efficiency and greater heat release. This, in turn, heats up and evaporates the unburned fuel more quickly, increasing the burning rate.

Liu et al. (2009) explained the mechanisms behind these trends in burning and heat release rate with separation distance. The nonmonotonic behavior seen in figure 5-5 is the result of two competing mechanisms: heat feedback enhancement and air entrainment restriction. As the burners are moved closer, the view factor between neighboring fires increases. In other words, the fires can “see” each other better, increasing the radiative heat transfer in addition to the convective heat transfer (Grumer and Strasser 1965). Because the burning rate is dictated by the heat feedback from the flame, this increased radiative heat seen by the fuel will evaporate the fuel more quickly and increase

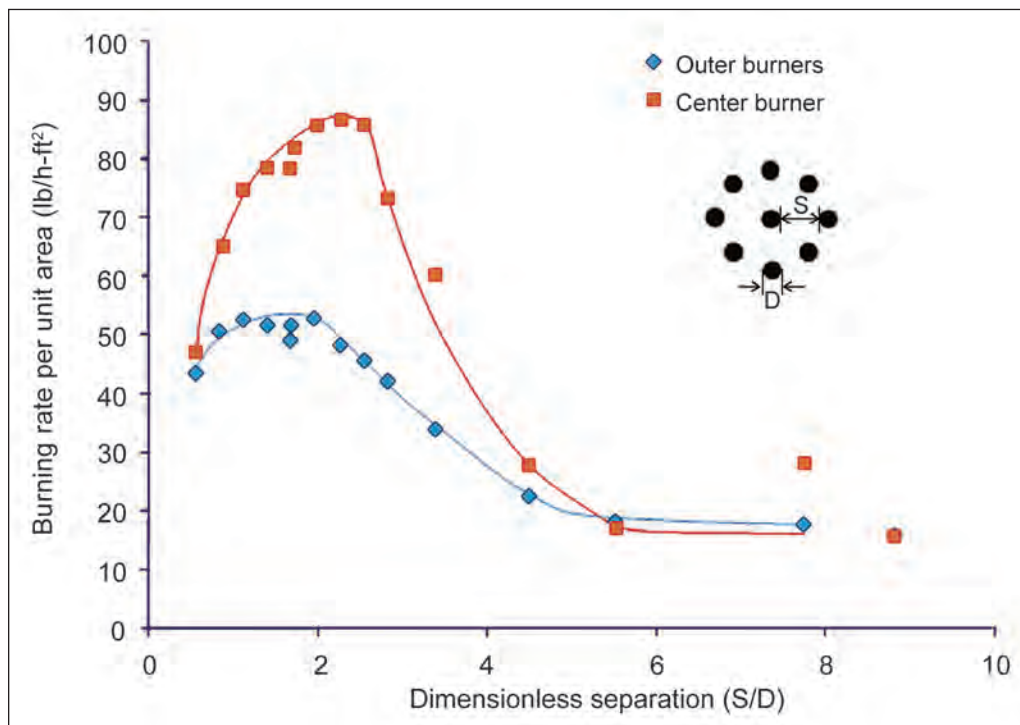

Figure 5-5—Burning rate as a function of separation distance for 10.1-cm-diameter cyclohexane burners (from Huffman et al. 1969).

the burning rate. Conversely, as the fires get sufficiently close, there is less room to entrain air inside the array and the flames become “choked.” When the flames are merely interacting, the heat feedback mechanism is more important than the air restriction and the burning rate increases. When the flames have merged, the air restriction is the dominant mechanism and the burning rate decreases.

Because the experiments by Kamikawa et al. (2005) used wood crib fires, they were also able to examine the release rate as a function of time for merged flames. As with most wildland fires, the heat release rate (and burning rate) of wood crib fires increases as the fire builds, reaches a maximum, then begins to decrease as the fuel is depleted. Kamikawa et al. (2005) observed that as the number of fires increases, the peak heat release rate increases above that expected by multiplying the independent fire heat release rate by the number of fires. This discrepancy grows as the number of fires increases. So the burning and heat release rates of interacting and merging fires not only are dependent on the spacing of the fires, but also on the total number of fires (see also Liu et al. 2009).

Fire interactions can increase burning rates by another mode as well. If the fires interact such that vorticity is generated, fire whirls can form. Although not discussed further here, it has been shown that fire whirls have dramatically increased burning rates in comparison to an equivalent, nonrotating fire (see, for example, Emmons 1965, Grishin et al. 2004 and chapter 8 of this volume).

Flame Dimensions

Flame height trends for a nonpremixed flame, such as those in a wildfire, are usually discussed in terms of two dimensionless parameters: the dimensionless flame height and the dimensionless heat release rate. The dimensionless flame height is usually defined as the flame height divided by the characteristic burning area diameter (D). The characteristic burning area diameter is a dimensioned parameter frequently introduced in fire arrays and is usually some function of the number of fires, fire diameter, and the fire arrangement (separation distance). The dimensionless heat release rate (Q^*) is usually defined as the total heat release rate of the group divided by the characteristic burning area diameter

to the five-halves power (material property constants are used to make the ratio dimensionless: $Q^* \sim Q_{tot}/D^{5/2}$). The dimensionless heat release rate for natural fires tends to fall between 0.05 and 5 (McCaffrey 1995).

Much of the research on flame height has been performed using gas burners. However, two regimes of flow from a gas burner can be identified. When the flow velocity is low or the burner diameter is large, the momentum of the gaseous fuel is due primarily to its buoyancy. When the flow velocity is high or the burner diameter is small, the flow is like a jet. Putnam and Speich (1963) have a method for determining whether the flow from a gas burner is a high-momentum jet or buoyancy controlled. The discussion here will be limited to turbulent, buoyancy-driven flames, as this situation better describes what occurs during a wildfire.

In general, the flame height increases as the fires are moved closer. When the flames begin to merge, the flame height will dramatically increase with further decreases in separation distance. However, once the flames are fully merged, further decreases in separation distance will have little effect (Chigier and Apak 1975, Fukuda et al. 2004, Putnam and Speich 1963). The dimensionless flame height has successfully been correlated to the dimensionless heat release rate raised to some power, a . Because the dimensionless heat release rate can range over at least seven orders of magnitude, this power “ a ” can take on three different values depending on the range of the dimensionless heat release rate. As shown in figure 5-6 (Quintiere and Grove 1998), the dimensionless flame height increases with the dimensionless heat release rate. These correlations were originally developed for the flame height of a single independent burner where the characteristic dimension is the burner diameter, and hold for buoyancy-driven gas burners, liquid pool fires, and wood crib fires. However, there is an indication that these correlations also apply to interacting flames when the characteristic burning area dimension is given as discussed above. For example, for the interaction of relatively tall flames compared to the actual burner diameter ($L_f/D > 1$, or high values of Q^*), Putnam and Speich (1963) and Sugawa and Takahashi (1993) showed that the dimensionless flame height correlates well with the dimensionless

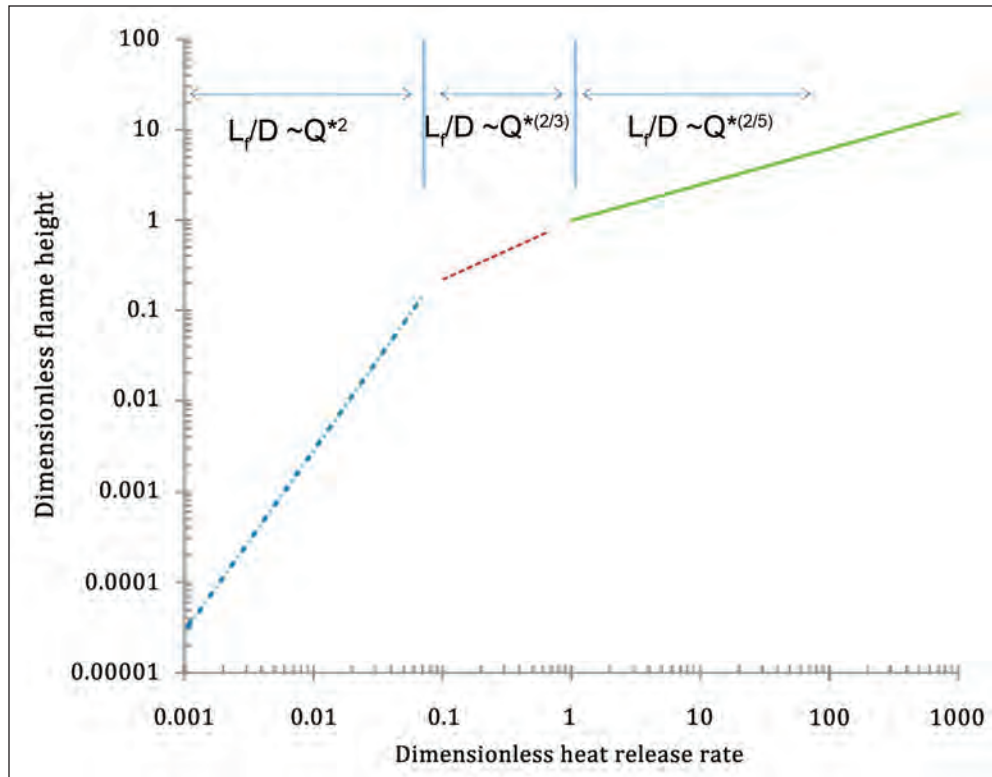

Figure 5-6—Dimensionless flame height (L_f/D) correlations with dimensionless heat release rate (Q^*) (Quintiere and Grove 1998).

heat release rate to the two-fifths power ($L_f/D \sim Q^{2/5}$). Delichatsios (2007) successfully correlated the dimensionless flame height to the dimensionless heat release rate to the two-thirds power ($L_f/D \sim Q^{2/3}$) for Q^* between 0.1 and 1. On the other hand, Weng et al. (2004) and Kamikawa et al. (2005) showed that the data for merged flame height is better correlated with the exponent “ a ” varying with the number of burners.

With all else remaining constant, these correlations suggest that an increase in either the number of fires or the individual fire heat release rate will increase the interacting or merged flame height. Increases in the separation distance or the fire diameter will result in a decrease in the interacting or merged flame height. An interesting caveat to these correlations is that the burning rate for individual pool or crib fires is not constant, but is a function of the separation distance as discussed above. This trend is not necessarily captured in figure 5-6 or by Putnam and Speich (1963) (gas burners), Kamikawa et al. (2005), Fukuda et al. (2004), or

Delichatsios (2007) (all fully merged flames). Also, vorticity can greatly increase flame height as well (Emmons 1965).

This literature suggests that in a mass fire situation, as the flames grow closer together, the heat release rate and characteristic “burner” diameter should increase. The net effect is most likely an increase in the flame height. If more spot fires were ignited in the burning area, for example, the flame height would increase further. This is consistent with the observations of spot ignitions on prescribed burns (Johansen 1984) and mass spotting in wildfires (Cheney and Bary 1969). However, for a sufficiently large area or mass fire, when the nondimensional group $N \sim Q^2/D^5$ is near 10^{-6} , the fire is not expected to burn as a continuous flame but will break up into many distributed flamelets (Countryman 1969, Heskestad 1991, Wood et al. 1971). In this case, the flame height will be less than that predicted for a fully merged, continuous flame but larger than that of isolated flames (Thomas 1963).

Flame Temperatures and Pollutants

In relation to flame height, as fires are moved closer together, air entrainment is blocked and the gaseous fuel must travel higher to find sufficient air for combustion. Experiments by Chigier and Apak (1975) indicated that a fuel particle journeying from the base to the tip of an interacting turbulent flame would experience delayed combustion compared to an independent flame (see fig. 5-7a). The delay means that the maximum temperature of the interacting flames would occur farther from the flame base. With limited mixing of fresh air into the flame to provide cooling, the temperatures inside an interacting flame decay more slowly with height so the flame is hot over a greater portion. In addition, limited mixing of air into the flames causes the formation of more carbon monoxide inside the flame zone. This prompted Countryman (1969) to speculate that the lack of oxygen in conjunction with elevated carbon monoxide could be fatal to ground personnel trapped inside the burning area.

Chigier and Apak (1975) also showed that the maximum temperature achieved by interacting turbulent flames is also a function of the separation distance and the number of burners (see fig. 5-7b). When the flames are close enough to interact, they lose less heat from radiation (the surroundings are at the same temperature) and by mixing with cool, fresh air. The maximum temperatures inside interacting flames therefore increase as the number of fires increase and as the burners get closer together. These increased temperatures could produce more of the smog-forming nitrogen oxide emissions (Tarr and Allen 1998).

Indraft Velocity

In typical fire situations where the flame height is relatively tall compared to the fire diameter, standard correlations exist to predict the mass of air entrained by the fire and its plume owing to the velocity difference between the plume gases and the ambient air. This air entrainment causes an inflow into the fire and is generally responsible for the bending of two flames in relative proximity. However, the standard correlations of plume theory are valid only above the flame. Although several plume theories exist

in the literature (see review in Heskestad 2008), there is general agreement that the total mass of air entrained can be estimated as proportional to the convective heat release rate (heat release rate minus radiative and other losses) raised to the one-third power and to the height above the fire source to the five-thirds power. Fires with greater heat release rate entrain more air, and the total amount of air entrained increases with height above the plume. Note, however, that the velocity of the flow inside the plume decreases with height, so at some point near the top of the plume no further air is entrained (no velocity difference). Current research on the indraft caused by entrainment as related to fire interactions is focused mainly on providing better quantitative predictions with computational fluid dynamics modeling (Morvan et al. 2009, Roxburgh and Rein 2010).

However, plumes from wildfires can interact with local meteorology (Weber and Dold 2006) such as wind and atmospheric conditions. Additionally, classic plume theory for entrainment rates may not hold for small ratios of the flame height to fire diameter (L_f/D). Although the exact threshold is not known, Heskestad (2008) contended that the standard plume theory falls apart for L_f/D somewhere between 0.14 to 0.9. The perimeter of the plume where entrainment occurs becomes too small in relation to the volume of air inside and the slow-moving entrained air will not have much effect on the momentum of the entire plume. Mass fires by definition fall into the range of flame height-to-fire diameter ratios where classic plume theory does not hold. The results of the Project Flambeau burns confirm that there is little entrainment into the plume core (Palmer 1981). Many authors (e.g., Adams et al. 1973, Small et al. 1983, Smith et al. 1975) also argue that the entrainment of plume theory does not account for the reported high-velocity winds associated with mass fires. As discussed earlier, mass fires are characterized by such strong indrafts that the fire does little outward propagation. In their review of the range of possible indraft velocities, Trelles and Pagni (1997) showed that indraft velocities of large fires can range from about 2 to 40 m/s. In the Project Flambeau burns, Countryman (1964, 1965, 1969) also reported complicated airflow patterns and strong downdrafts that cannot be accounted for with simple plume theory.

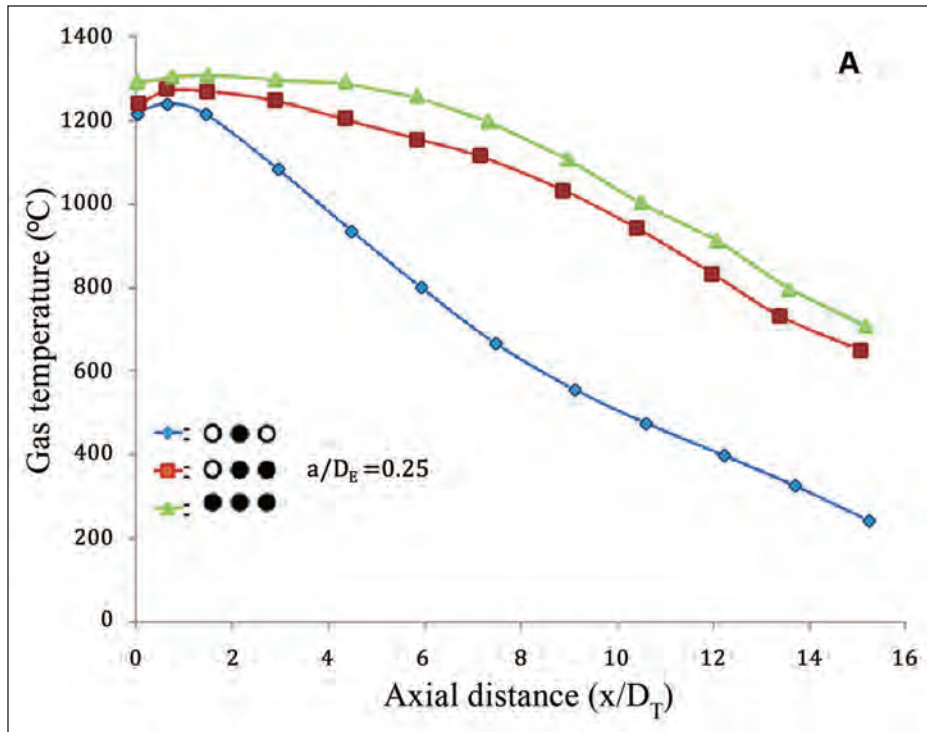

Figure 5-7a—Effect of nearby burners on flame temperature (from Chigier and Apak 1975). D_T is throat diameter, D_E is exit diameter, a is separation distance.

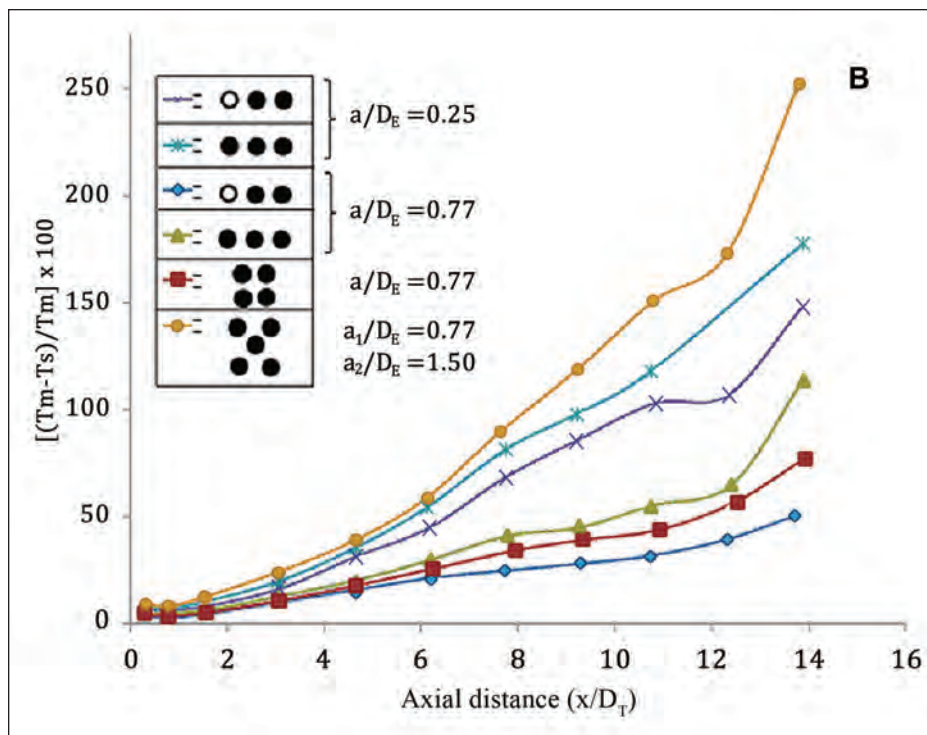

Figure 5-7b—Temperature compared to independent flame for varying axial distance along flame, number of burners, burner arrangement, and burner spacing (from Chigier and Apak 1975). T_m is merged flame temperature, and T_s is single flame temperature.

There seem to be two main theories in the literature as to what causes the high-velocity inflows. One theory, advanced by Baum and McCaffrey (1989) and Carrier et al. (1985) is that large-scale vorticity in conjunction with heat release is responsible. These models contend that the entire fire plume slowly rotates. Note, however, that Church et al. (1980) and McRae and Flannigan (1990) characterized this type of motion as one type of fire whirl. In Baum and McCaffrey's model (also used by Trelles and Pagni 1997 and Ohlemiller and Corley 1994), this rotation is caused by density gradients from the high heat release, and not necessarily by any imposed swirling caused by the ambient environment. The slow rotation of such a large mass of air above the ground translates to high-velocity, purely horizontal, and nonrotating flow at the ground. One unique feature of the Baum and McCaffrey model is that it treats the large area fire as an ensemble of randomly distributed individual fires of varying strengths. Because of the method chosen to represent the fire, the model is only valid for heights above the fuel bed where the plumes of the individual fires have not merged. The model of Carrier et al. (1985) was intended to determine how long it would take to spin up the convective column and under what conditions this occurred. Based on the fact that the fire in Hamburg, Germany, took 2 h to develop, they concluded that the growth of swirl, at least in this case, was most likely due to the intensification of a preexisting vortex from earlier fires and bombings. Although this contradicts the Baum and McCaffrey model, the experiments and discussion by Church et al. (1980) support this argument. The spatial orientation of individual fires may cause a swirling flow owing to the interaction of the indrafts to each fire (Soma and Saito 1991). Carrier et al. (1985) found that large-diameter plumes spin up faster, and proposed a set of four criteria that must be met for a "firestorm" to develop: heat release of 10^6 MW over a localized area for 2 to 3 h, a preexisting weak vortex, low ambient winds, and a nearly dry-adiabatic lapse rate over the first few kilometers of the atmosphere.

Because it seems unlikely that all the criteria for spin-up of a convective column will be met, another theory, advanced by Smith et al. (1975) and Small et al. (1983) is

proposed. These authors claimed that buoyancy-induced pressure gradients are responsible for the large indrafts. Smith et al. (1975) used a simple two-dimensional model of a convective column over a hot area to effectively show that near the fire, a dynamic pressure gradient can cause high-velocity inflow. This dynamic pressure gradient is caused by a balance between hydrostatic pressure and buoyancy. Buoyancy pushes the hot gases up while atmospheric pressure pushes fresh air at the ground in toward the fire horizontally to fill the gap left by the rising gases. Smith et al. (1975) also suggested that the traditional "weakly buoyant" plume theories described above may be valid for a small range of plume heights sufficiently far away from the fire and any inversion layer above. Small et al. (1983) used a similar model to Smith et al. (1975) but included a volume heat addition and large density and temperature gradients. Small et al. (1983) also numerically matched their model results of the area near the fire to the results of traditional plume theory for the region far from the fire. In both the Smith et al. (1975) and Small et al. (1983) models, the fire is treated as a single large heat source (fig. 5-8). Small et al. (1983) used their model to demonstrate how the maximum indraft velocity varies with fire radius, burning rate, and fire height (fig. 5-8). They showed that the maximum indraft velocity at first increases but eventually levels off (to about 40 m/s) with increases in both the fire radius and the burning rate. On the other hand, the maximum indraft velocity appears to be linear with fire height.

A third, yet not well-explored, explanation was proposed by Carrier et al. (1984). In this work, they used classic plume theory but assumed that the fire does not burn as a single fire, but a collection of individual fires. They hypothesized that the high indraft velocities are then due to the increased fire perimeter from this "multicellular burning zone." This hypothesis was not further developed, and in later works, these authors treated the fire as a subterranean point source. Interestingly, both the Baum and McCaffrey (1989) and Small et al. (1983) models reasonably replicate what little experimental data are available. However, the theories differ slightly in their predictions of the distance away from the fire that these indrafts extend (Pitts 1991).

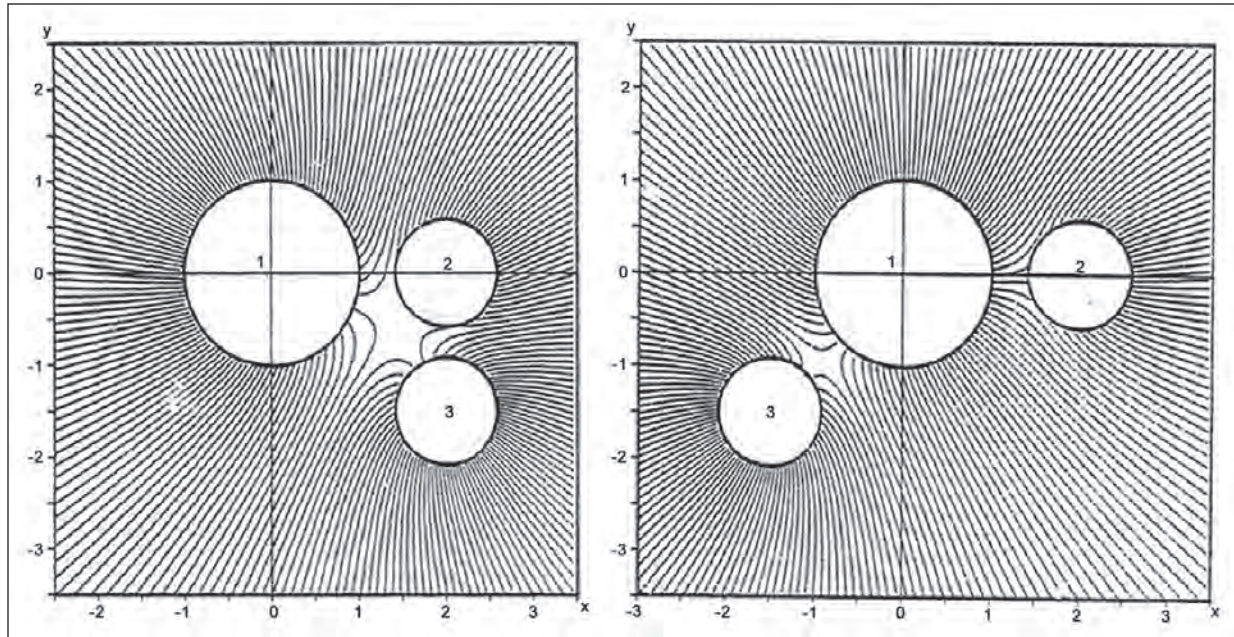

Figure 5-8—Model results for flow-field streamlines for three fires in proximity (from Weihs and Small 1986).

The model of Baum and McCaffrey (1989) predicts that the high-velocity indrafts will extend much farther from the fire compared to the model of Small et al. (1983). Without more detailed experimental data, it is impossible to say which model more accurately portrays the physics.

Pulsation

Although not an effect of flame interactions, flame pulsation (or puffing) is an interesting phenomenon that can occur in stationary fires, such as a mass fire. This pulsation typically occurs in circular or axisymmetric fires in weak ambient wind and is periodic in nature. Flame pulsation is important to many researchers because it can have a great influence on air entrainment rates and therefore heat release rates and pollution formation (Ghoniem et al. 1996). Observations of this phenomenon reveal the expansion of the flame near the base of the fire as a toroidal vortex, about the size of the fire diameter. As this vortex is shed and propagates upward, the flame necks inward giving the appearance of a “mushroom” shape. Figure 5-9 illustrates the process with time sequence of photos. Not all circular flames pulsate, however. Using

dimensional analysis, Byram and Nelson (1970) attempted to describe what type of fires will pulsate. They defined a dimensionless “buoyancy” number, $\pi_2 = \dot{Q}_c / [(gD)^{0.5} \rho c_p T]$, where \dot{Q}_c is the rate of convective heat release per area, g is the gravitational acceleration, D is the fire diameter, and ρ , c_p , and T are the density, specific heat, and temperature of the ambient air. Although no quantitative values were given, they argued that a fire will not pulsate if π_2 is either too small (low heat release rate relative to large fire diameter) or too large (large heat release rate relative to small fire diameter).

Because this puffing also occurs in nonreacting helium plumes, it is actually not caused by a combustion instability, but instead is produced by a fluid dynamic instability (Cetegen and Ahmed 1993). There is disagreement about the actual cause of the instability (Tieszen 2001), but the vortex is generally thought to be formed because of the interaction between gravity and the density gradient between the flame and ambient air temperatures (Ghoniem et al. 1996).

Most of what has been learned about the characteristics of pulsation has been learned through experiments. Cetegen

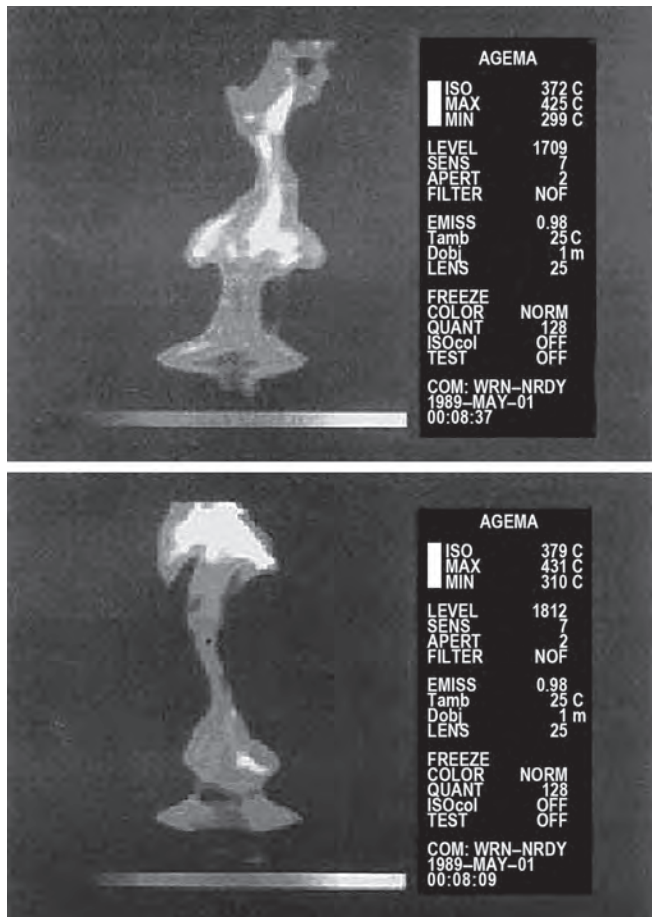

Figure 5-9—Thermal images of flame pulsation (from Malalasekera et al. 1996).

and Ahmed (1993) showed that the toroidal vortex forms within one fire diameter above the flame base and that the frequency of the puffing is insensitive to the fuel or the heat release rate. By plotting the available data in the literature, Cetegen and Ahmed (1993), and later Malalasekera et al. (1996), showed that the pulsation frequency is proportional to the fire diameter raised to the negative one-half power ($f \sim D^{-1/2}$) so that large fires pulsate at a much lower frequency than small fires. Though this correlation was developed using data from fires ranging from 0.1 to 100 m in diameter (four orders of magnitude) using gaseous, liquid and solid fuels, Baum and McCaffrey (1989) suggested that it may well hold for much larger fires as well. For a large fire

with a diameter on the order of 20 km, Larson et al. (1982) estimated that the pulsation will occur every 20 minutes. Although it is not accounted for in the above correlation, Malalasekera et al. (1996) showed that increasing fuel flow rates also result in a small increase in puffing frequency, especially for small fire sizes. Because of this, Malalasekera et al. (1996) correlated the puffing frequency in a slightly different manner using the dimensionless Strouhal number (ratio of oscillation frequency to 1 over the characteristic time of convection) and Froude number (ratio of inertia force to gravitational force), which retains the same dependency on fire diameter but allows for a correction owing to changes in fuel flow velocity.

Convection Column

Mass fires are also described as having very tall convection columns, or smoke plumes with large cloud structures because of the moisture release from combustion (Small and Heikes 1988). As discussed in the section on indraft velocities, the entrainment of cold, ambient air slows the rise of the hot gases by cooling them. Additionally, the density of the ambient air itself decreases with elevation. As the hot gases rise and cool, the density difference driving their upward motion disappears. It follows then that the top of the smoke plume corresponds to the height where the combustion products stop rising. As the fire diameter grows, however, the entrainment predicted by classic plume theory becomes less effective. Entrainment occurs at the perimeter of the plume, and with large fire sources, there is such a large core of hot gases that entrainment is less effective at slowing the rise of the combustion products (Palmer 1981). Thus, it takes longer to entrain enough cold air to slow the combustion products, and therefore the smoke plume becomes taller. For example, a lack of entrainment to the convection column was noted and discussed by Taylor et al. (1973) on a large prescribed burn. In fact, the plume from a sufficiently large mass fire may be almost as wide as it is tall, so Brode and Small (1986) and Palmer (1981) contended that air entrainment is not likely to be a major influence on plume height and that it is the structure of the

atmosphere itself that is the limiting factor. The plume of large mass fires is therefore more sensitive to atmospheric gradients, inversion heights, and upper atmosphere crosswinds (see also Penner et al. 1986). Brode and Small (1986) showed that the tropopause/stratosphere transition may be what actually caps the smoke plume. Note, these theories contradict the suggestion of Smith et al. (1975) that the traditional plume theory holds at some intermediate height above the ground. Perhaps the scale of the fires modeled by Smith et al. (1975) was not large enough to see this effect.

Palmer (1981) described the interesting structure of the convection columns that formed during the Project Flambeau tests. In the first few minutes of these large-scale burns, the majority of the gaseous combustion products were contained in a “bubble” near the fire. Once the “bubble” got sufficiently hot, the associated buoyancy was enough to overcome the surface drag forces and the bubble rose. As the bubble rose, a vortex ring would form in a similar manner described above with respect to flame pulsations. Regardless of the atmospheric stability, this vortex ring would rise until it encountered a region of vertical wind shear. The vertical wind shear weakened the vortex enough for the plume to then follow the prevailing horizontal winds. Palmer (1981) also noted that the “exterior form of the convection column at a particular altitude was determined by the initial vortex bubble as it passed that altitude.” Most of the plumes in these fires began to rotate as a single vertical vortex, as suggested by the Baum and McCaffrey (1989) model. This rotation further inhibits entrainment, which would also prevent the use of classic plume models for mass fires (Banta et al. 1992).

Summary of Interaction Effects

As the individual spot fires grow together, they will begin to interact. This interaction will increase the burning rates, heat release rates, and flame height until the distance between them reaches a critical level. At the critical separation distance, the flames will begin to merge together and burn with the maximum rate and flame height. As these spot fires continue to grow together, the burning and heat release rates will finally start to decrease but remain at a much elevated

level compared to the independent spot fire. The flame height is not expected to change significantly. The more spot fires, the bigger the increase in burning rate and flame height.

Needs for Further Research and Application

The characteristics of many fire interactions have been examined and reported in the research literature, leaving little doubt that local spread and behavior experienced by wildland fire personnel can be greatly influenced by fire configurations at larger scales. The ignition patterns and “suppression fire” tactics used in firefighting (Castellnou et al. 2010, Miralles et al. 2010) depend on understanding these interactions. However, questions remain about how to extend the findings of fundamental research to the field scale for wildland fires and mass fires. In particular, there is no clear method to determine the minimum separation distance between two fires for interaction and merging to occur. The influence of ambient winds or topography on interactions is directly relevant to wildfire management activities and tactics but has not been explored. Large-area fires were discussed as an extreme case of fire interactions and often behave quite differently than propagating line fires. Just how much area must be ignited to display “mass fire” characteristics is unknown. Even in the Project Flambeau experiments, Countryman (1964) argued that these large fires were not large enough to be considered mass fires. Both Byram (1966) and Thomas et al. (1968) developed scaling laws in an attempt to answer this question, but many potentially limiting assumptions were made in the development and the laws were not validated. Baldwin and North (1967) attempted to quantify the minimum area for urban applications based on city layout and historical fires, but their estimations are admittedly crude. As discussed, there is no consensus in the literature about the convection column dynamics of mass fires and what mechanism is responsible for the reported strong indrafts. These suggestions are merely a starting point, as the subjects of fire interactions and mass fires clearly involve a great deal of physics and require the union of many fields of study.

Literature Cited

- Adams, J.S.; Williams, D.W.; Tregellas-Williams, J. 1973.** Air velocity, temperature, and radiant-heat measurements within and around a large free-burning fire. Symposium (International) on Combustion. 14: 1045–1052.
- Albini, F.A. 1981.** A model for the wind-blown flame from a line fire, *Combustion and Flame*. 43: 155–174.
- Albini, F.A. 1982.** Response of free-burning fires to nonsteady wind, *Combustion Science and Technology*. 29: 225–241.
- Anderson, H.E. 1968.** The Sundance Fire. Res. Pap. INT-56. Ogden, UT: U.S. Department of Agriculture, Forest Service, Intermountain Forest and Range Experiment Station. 39 p.
- Arnold, R.K.; Buck, C.C. 1954.** Blow-up fires—silviculture or weather problems. *Journal of Forestry*. 1954(June): 408–411.
- Baldwin, R. 1966.** Some tentative calculations of flame merging in mass fires. Fire Research Note. 629. Boreham Wood, Hertfordshire, England: Fire Research Station.
- Baldwin, R. 1968.** Flame merging in multiple fires. *Combustion and Flame*. 12(4): 318–324.
- Baldwin, R.; North, M.A. 1967.** The firestorm—its size and importance. Fire Research Note. 645. Boreham Wood, Hertfordshire, England: Fire Research Station.
- Baldwin, R.; Thomas, P.H.; Wraight, H.G.G. 1964.** The merging of flames from separate fuel beds. Fire Research Note. 551. Boreham Wood, Hertfordshire, United Kingdom: Fire Research Station.
- Banta, R.M.; Olivier, L.D.; Holloway, E.T.; Kropfli, R.A.; Bartram, B.W.; Cupp, R.E.; Post, M.J. 1992.** Smoke-column observations from two forest fires using Doppler LIDAR and Doppler radar. *Journal of Applied Meteorology*. 31: 1328–1348.
- Baum, H.; McCaffrey, B. 1989.** Fire induced flow field—theory and experiment. *Fire Safety Science*. 2: 129–148.
- Beaufait, W.R. 1965.** Characteristics of backfires and headfires in a pine needle fuel bed. Res. Note INT-39. Ogden, UT: U.S. Department of Agriculture, Forest Service, Intermountain Forest and Range Experiment Station. 7 p.
- Beer, T. 1995.** Fire propagation in vertical stick arrays: the effects of wind. *International Journal of Wildland Fire*. 5(1): 43–49.
- Beverly, J.L.; Wotton, B.M. 1997.** Modelling the probability of sustained flaming: predictive value of fire weather index components compared with observations of site weather and fuel moisture conditions. *International Journal of Wildland Fire*. 16: 161–173.
- Bradstock, R.A.; Gill, A.M. 1993.** Fire in semi-arid Mallee shrublands: size of flames from discrete fuel arrays and their role in the spread of fire. *International Journal of Wildland Fire*. 3(1): 3–12.
- Brode, H.L.; Small, R.D. 1986.** A review of the physics of large urban fires. In: *The medical implications of war*. Washington, DC: Institute of Medicine, National Academies Press. 620 p.
- Brown, J.K. 1982.** Fuel and fire behavior prediction in big sagebrush. Res. Pap. INT-290. Ogden, UT: U.S. Department of Agriculture, Forest Service, Intermountain Forest and Range Experiment Station. 12 p.
- Bruner, A.D.; Klebenow, D.A. 1979.** Predicting success of prescribed fires in pinyon-juniper woodland in Nevada. Res. Pap. INT-219. Ogden, UT: U.S. Department of Agriculture, Forest Service, Intermountain Forest and Range Experiment Station. 12 p.
- Burrows, N.; Ward, B.; Robinson, A. 1991.** Fire behavior in spinefex fuels on the Gibson Desert Nature Reserve, Western Australia. *Journal of Arid Environments*. 20: 189–204.
- Byram, G.M. 1966.** Scaling laws for modeling mass fires. *Pyrodynamics*. 4: 271–284.

- Byram, G.M.; Nelson, R.M. 1970.** The modeling of pulsating fires. *Fire Technology*. 6(2): 102–110.
- Carrier, G.; Fendell, F.; Feldman, P. 1984.** Big fires. *Combustion Science and Technology*. 39: 135–162.
- Carrier, G.F.; Fendell, F.E.; Feldman, P.S. 1985.** Firestorms. *Journal of Heat Transfer*. 107: 19–27.
- Castellnou, M.; Kraus, D.; Miralles, M.; Delogu, G. 2010.** Suppression fire use in learning organizations. In: Silva, J.S.; Rego, F.; Fernandes, P.; Rigolot, E., eds. *Towards integrated fire management—outcomes of the European Project Fire Paradox*. Res. Rep. 23. Joensuu, Finland: European Forest Institute: 189–201. Chapter 5.2.
- Catchpole, E.A.; DeMestre, N.J.; Gill, A.M. 1982.** Intensity of fire at its perimeter. *Australian Forest Research*. 12: 47–54.
- Cetegen, B.M.; Ahmed, T.A. 1993.** Experiments on the periodic instability of buoyant plumes and pool fires. *Combustion and Flame*. 93: 157–184.
- Chandler, C.C. 1963.** A study of mass fires and conflagrations. Res. Note PSW-N22. Berkeley, CA: U.S. Department of Agriculture, Forest Service, Pacific Southwest Forest and Range Experiment Station. 9 p.
- Chandler, C.C.; Storey, T.G.; Tangren, C.D. 1963.** Prediction of fire spread following nuclear explosions. Res. Pap. PSW-5. Berkeley, CA: U.S. Department of Agriculture, Forest Service, Pacific Southwest. Forest and Range Experiment Station. 110 p.
- Cheney, N.P. 1981.** Fire behavior. In: Gill, A.M.; Groves, R.H.; Noble, I.R., eds. *Fire and the Australian biota*. Canberra, A.C.T.: Australian Academy of Science: 151-175. Chapter 7.
- Cheney, N.P.; Bary, G.A.V. 1969.** The propagation of mass conflagrations in a standing eucalypt forest by the spotting process. In: *Proceedings, Mass fire symposium*. Canberra, Australia: Defense Standards Laboratory: 1 (Sessions A and B): 1–11.
- Cheney N.P.; Gould, J.S. 1995.** Fire growth in grassland fuels. *International Journal of Wildland Fire*. 5: 237–247.
- Chigier, N.A.; Apak, G. 1975.** Interaction of multiple turbulent diffusion flames. *Combustion Science and Technology*. 10(5–6): 219–231.
- Church, C.R.; Snow, J.T.; Dessens, J. 1980.** Intense atmospheric vortices associated with a 1000 MW fire. *Bulletin of the American Meteorological Society*. 61 (7): 682–694.
- Countryman, C.M. 1964.** Mass fires and fire behavior. Res. Pap. PSW-19. Berkeley, CA: U.S. Department of Agriculture, Forest Service, Pacific Southwest Forest and Range Experiment Station. 53 p.
- Countryman, C.M. 1965.** Mass fire characteristics in large scale tests. *Fire Technology*. 2: 303–317.
- Countryman, C.M. 1969.** Project Flambeau... an investigation of mass fire (1964–1967) final report. Prepared for Office of Civil Defense under OCD Work Order No. OCD-PS-65-26. Berkeley, CA: U.S. Department of Agriculture, Forest Service, Pacific Southwest Forest and Range Experiment Station. Volume 1.
- Curry, J.R.; Fons, W.L. 1938.** Rate of spread of surface fires in the ponderosa pine type of California. *Journal of Agriculture Research*. 57(4): 239–266.
- Delichatsios, M. 2007.** A correlation for the flame height in “group” fires. *Fire Science and Technology*. 26(1): 1–8.
- Dold, J.W.; Zinoviev, A. 2009.** Fire eruption through intensity and spread rate interaction mediated by flow attachment. *Combustion Theory and Modeling*. 13(5): 763–793.
- Dold, J.W.; Zinoviev, A.; Weber, R.O. 2006.** Nonlocal flow effects in bushfire spread rates. Paper presented at V International conference on forest fire research. Manchester, United Kingdom: University of Manchester. 9 p.
- Eggleston, L.A. 1968.** Electronic simulation of mass fires. Spring meeting of the Central States Section of the Combustion Institute. Los Angeles, CA: University of Southern California: 1–11.

- Emmons, H.W. 1965.** Fundamental problems of the free burning fire. Symposium (International) on Combustion. 10: 951–964.
- Emori, R.I.; Saito, K. 1983.** A study of scaling laws in pool and crib fires. Combustion Science and Technology. 31: 217–231.
- Fendell, F.E.; Wolff, M.F. 2001.** Wind-aided fire spread. In: Johnson, E.A.; Miyanishi, K., eds. Forest fires: behavior and ecological effects. Maryland Heights, MO: Academic Press: 171–223.
- Finney, M.A.; Cohen, J.D.; Yedinak, K.M.; Grenfell, I.C. 2010.** An examination of fire spread thresholds in discontinuous fuelbeds. International Journal of Wildland Fire. 19(2): 163–170.
- Fosberg, M.A. 1967.** Evaluation of the natural length scale in mass fires. Proceedings: Tripartite technical cooperation program panel N-3 (thermal radiation) mass fire research symposium, DASA 1949. Special Report 59. Defense Atomic Support Agency Information and Analysis Center.
- Fukuda, Y.; Kamikawa, D.; Hasemi, Y.; Kagiya, K. 2004.** Flame characteristics of group fires. Fire Science and Technology. 23(2): 164–169.
- Gebhart, B.; Shaukatullah, H.; Pera, L. 1976.** The interaction of unequal laminar plane plumes. International Journal of Heat and Mass Transfer. 19: 751–756.
- German, D. 1968.** Mass fire infrared measurements. Report No. D3-7655. Wichita, KS: Boeing Company.
- Ghoniem, A.F.; Lakkis, I.; Soteriou, M. 1996.** Numerical simulation of the dynamics of large fire plumes and the phenomenon of puffing. Symposium (International) on Combustion. 26: 1531–1539.
- Grishin, A.M.; Golovonov, A.N.; Sukov, Y.V. 2004.** Physical modeling of firestorms. Doklady Physics. 49(3): 191–193.
- Grumer, J.; Strasser, A. 1965.** Uncontrolled fires –specific burning rates and induced air velocities. Fire Technology. 1(4): 256–268.
- Heskestad, G. 1991.** A reduced-scale mass fire experiment. Combustion and Flame. 83: 293–301.
- Heskestad, G. 1998.** Dynamics of the fire plume. Philosophical Transactions of the Royal Society of London: A356: 2815–2833.
- Heskestad, G. 2008.** Fire plumes, flame height, and air entrainment. In: Di Nenno, P.J. et al., eds. SFPE handbook of fire protection engineering. 4th ed. Quincy, MA: National Fire Protection Association: 2.1–2.20.
- Hewitt, K. 1983.** Place annihilation: area bombing and the fate of urban places. Annals of the Association of American Geographers. 73(2): 257–284.
- Huffman, K.G.; Welker, J.R.; Sliepcevich, C.M. 1969.** Interaction effects of multiple pool fires. Fire Technology. 5(3): 225–232.
- Johansen, R.W. 1984.** Prescribed burning with spot fires in the Georgia coastal plain. Forest Res. Pap. 49. Macon, GA: Georgia Forestry Commission. 6 p.
- Johansen, R.W. 1987.** Ignition patterns and prescribed fire behavior in southern pine forests. Forest Res. Pap. 72. Macon, GA: Georgia Forestry Commission.
- Kamikawa, D.; Wend, W.G.; Kagiya, K.; Fukuda, Y.; Mase, R.; Hasemi, Y. 2005.** Experimental study of merged flames from multifire sources in propane and wood crib burners. Combustion and Flame. 142: 17–23.
- Kucuk, O.; Bilgili, E.; Baysal, I. 2007.** Fire development from a point source in surface fuels of a mature Anatolian black pine stand. Turkish Journal of Agriculture and Forestry. 31: 263–273.
- Larson, D.A.; Brode, H.L.; Small, R.D. 1982.** Time-dependent model of flows generated by large area fires. Note 483. Los Angeles, CA: Pacific-Sierra Research Corp.

- Larson, D.A.; Small, R.D. 1982a.** Analysis of the large urban fire environment; Part I. Theory. PSR Report 1210. Final report contract EMW-C-0747. Arlington, VA: Pacific-Sierra Research Corp.
- Larson, D.A.; Small, R.D. 1982b.** Analysis of the large urban fire environment. Part II. Parametric analysis and model city simulations. PSR Report 1210. Final report contract EMW-C-0747. Arlington, VA: Pacific-Sierra Research Corp.
- Lee, B.T. 1969a.** Mass fire scaling with small electrically heated models. Spring meeting of the Central States Section of the Combustion Institute. Minneapolis, MN: University of Minnesota: 1–2.
- Lee, B.T. 1969b.** Mass fire scaling with small electrically heated models,” NRDL-TR-69. Final report, Office of Civil Defense contract No. DAHC20-67-C-0149. San Francisco, CA: Naval Radiological Defense Laboratory.
- Leonard, S. 2009.** Predicting sustained fire spread in Tasmanian native grasslands. *Environmental Management*. 44: 430–440.
- Liu, N.; Liu Q.; Deng, Z.; Satoh, K.; Zhu, J. 2007.** Burn-out time data analysis on interaction effects among multiple fires in fire arrays. *Proceedings of the Combustion Institute*. 31: 2589–2597.
- Liu, N.; Liu, Q.; Lozano, J.S.; Shu, L.; Zhang, L.; Zhu, J.; Deng, Z.; Satoh, K. 2009.** Global burning rate of square fire arrays: experimental correlation and interpretation. *Proceedings of the Combustion Institute*. 32: 2519–2526.
- Lommasson, T.E.; Keller, J.A.; Kirkpatrick, R.G. 1967.** Firestorm analysis. DC–TN-2046-1. Division of Fire Research U.S. Forest Service contract No. 13-248. Los Angeles, CA: Dikewood Corporation.
- Lommasson, T.E.; Miller, R.K.; Kirkpatrick, R.G.; Keller, J.A. 1968.** A firestorm existence and buildup hypothesis. DC-FR-1058.0. Defense Atomic Support Agency contract No. DASA 01-67-C-0008. Los Angeles, CA: Dikewood Corporation.
- Luke, R.H.; McArthur, A.G. 1978.** Bushfires in Australia. Canberra, ACT, Australia: Australian Government Publishing Service. 359 p.
- Malalasekera, W.M.G.; Versteed, H.K.; Gilchrist, K. 1996.** A review of research and an experimental study on the pulsation of buoyant diffusion flames and pool fires. *Fire and Materials*. 20: 261–271.
- Marsden-Smedley, J.B. 2009.** Planned burning in Tasmania: Operational guidelines and review of current knowledge. Hobart, Tasmania: Fire Management Section, Parks and Wildlife Service, Department of Primary Industries, Parks, Water and the Environment.
- Marsden-Smedley, J.B.; Catchpole, W.R.; Pryke, A. 2001.** Fire modeling in Tasmanian buttongrass moorlands. IV. Sustaining versus non-sustaining fire. *International Journal of Wildland Fire*. 10: 255–262.
- Martin, R.E.; Dell, J.D. 1978.** Planning for prescribed burning in the inland Northwest. Gen. Tech. Rep. GTR-76. Portland, OR: U.S. Department of Agriculture, Forest Service, Pacific Northwest Forest and Range Experiment Station. 74 p.
- Martin, R.E.; Finney, M.A.; Molina, D.M.; Sapsis, D.B.; Stephens, S.L.; Scott, J.H.; Weise, D.R. 1991.** Dimensional analysis of flame angles versus wind speed. In: Andrews, P.L.; Potts, D., eds. 11th conference on fire and forest meteorology. Bethesda, MD: Society of American Foresters: 212–218.
- McAlpine, R.S.; Wakimoto, R.H. 1991.** The acceleration of fire from point source to equilibrium spread. *Forestry Science*. 37(5): 1314–1337.
- McArthur, A.G. 1969a.** The behavior of mass fires in felled eucalypt forest originating from a simultaneous grid or line ignition system. Paper A1. In: Mass fire symposium, Canberra, Australia: Defense Standards Laboratory: 1–34.

- McArthur, A.G. 1969b.** The Tasmanian bushfires of 7th February, 1967, and associated fire behavior characteristics. Paper A7. In: Mass fire symposium. Canberra, Australia: Defense Standards Laboratory: 1–23.
- McCaffrey, B. 1995.** Flame heights. SFPE Handbook of fire protection engineering. 2nd ed. Quincy, MA: National Fire Protection Association.
- McRae, D.J. 1999.** Point-source fire growth in jack pine slash. *International Journal of Wildland Fire*. 9 (1): 65–77.
- McRae, D.J.; Flannigan, M.D. 1990.** Development of large vortices on prescribed fires. *Canadian Journal of Forest Research*. 20: 1878–1887.
- McRae, D.J.; Jin, J.-Z.; Conard, S.G.; Sukhinin, A.I.; Ivanova, G.A.; Blake, T.W. 2005.** Infrared characterization of fine-scale variability in behavior of boreal forest fires. *Canadian Journal of Forest Research*. 35: 2194–2206.
- Miralles, M.; Kraus, D.; Molina, F.; Loureiro, C.; Delogu, G.; Ribet, N.; Vilalta, O. 2010.** Improving suppression fire capacity. In: Silva, J.S.; Rego, F.; Fernandes, P., Rigolot, E., eds. *Towards integrated fire management—outcomes of the European Project Fire Paradox*. Res. Rep. 23. Joensuu, Finland: European Forest Institute: 203–215. Chapter 5.3.
- Morvan, D.; Hoffman, C.; Rego, F.; Mell, W. 2009.** Numerical simulation of the interaction between two fire fronts in the context of suppression fire operations. 8th symposium on fire and forest metrology. Boston, MA: American Meteorological Society: 1–11.
- Nelson, R.M.; Adkins, C.W. 1986.** Flame characteristics of wind-driven surface fires. *Canadian Journal of Forest Research*. 16: 1293–1300.
- Nielson, H.J. 1970.** Mass fire data analysis. Final report for Defense Atomic Support Agency Report No. 2018. Project J6099 Chicago, IL: Illinois Institute of Technology Research Institute.
- Nielson, H.J.; Tao, K.; Wolf, L. 1963.** Analysis of convection column above a fire storm. Final report, Office of Civil Defense contract No. OCD-OS-62-82. Chicago, IL: Illinois Institute of Technology Research Institute.
- Nmira, F.; Consalvi, J.L.; Boulet, P.; Porterie, B. 2010.** Numerical study of wind effects on the characteristics of flames from non-propagating vegetation fires. *Fire Safety Journal*. 45: 129–141.
- Ohlemiller, T.; Corley, D. 1994.** Heat release rate and induced wind field in a large scale fire. *Combustion Science and Technology*. 97: 315–330.
- Palmer, T.Y. 1981.** Large fire winds, gases and smoke. *Atmospheric Environment*. 15(10/11): 2079–2090.
- Parker, W.J. 1967.** Urban mass fire scaling considerations. USNRDL-TR-67-150. U.S. San Francisco, CA: Naval Radiological Defense Laboratory, OCD Work Unit No. 2536F.
- Penner, J.E.; Haselman, L.C.; Edwards, L.L. 1986.** Smoke-plume distributions above large-scale fires: implications for simulations of “nuclear winter.” *Journal of Climate and Applied Meteorology*. 25: 1434–1444.
- Pera, L.; Gebhart, B. 1975.** Laminar plume interactions. *Journal of Fluid Mechanics*. 68(2): 259–271.
- Pipkin, O.A.; Sliepcevich, C.M. 1964.** The effect of wind on buoyant diffusion flames. *Industrial and Engineering Chemistry Fundamentals*. 3(May): 147–154.
- Pitts, W.M. 1991.** Wind effects on fires. *Progress in Energy and Combustion Science*. 17: 83–134.
- Pryor, A.J.; and Yuill, C.H. 1966.** Mass fire life hazard. Final report, Contract No. N228(62479)68665. San Antonio, TX: Southwest Research Institute, Office of Civil Defense Work Unit 2537A.
- Putnam, A.A.; Speich, C.F. 1963.** A model study of the interaction of multiple turbulent diffusion flames. *Symposium (International) on Combustion*. 9: 876–877.

- Quintiere, J.G. 1993.** Canadian mass fire experiment. *Journal of Fire Protection Engineering*. 5(2): 67–78.
- Quintiere, J.G.; Grove, B.S. 1998.** A unified analysis for fire plumes. *Proceedings of the Combustion Institute*. 27: 2757–2766.
- Rios, J. 1966.** Interaction effects of wind-blown proximate flames from burning wood cribs. Norman, OK: University of Oklahoma. Ph.D. dissertation.
- Rios, J.; Welker, J.R.; Sliepcevich, C.M. 1967.** Interaction of wind-blown flames from wood crib fires. *Fire Technology*. 3(2): 129–136.
- Rothermel, R.C. 1984.** Fire behavior considerations of aerial ignition. In: Mutch, R.W., tech. coord. *Prescribed fire by aerial ignition: Proceedings of a workshop*. Intermountain Fire Council: 143–158.
- Roxburgh, R.; Rein, G. 2008.** Study of wildfire in-draft flows for counter fire operations. *WIT Transaction on Ecology and the Environment. Proceedings of Forest Fires: Modelling, Monitoring, and Management of Forest Fires*, Toledo, Ohio. 119: 13–22.
- Sanderlin, J.C.; Ball, J.A.; Johanson, G.A. 1981.** Mass fire model concept. DNA 5803F. Final report for period 8 September 1980–31 May 1981. Contract No. DNA 001-80-C-0351. Santa Barbara, CA: Mission Research Corporation.
- Schmalz, R.F. 1992.** Conflagrations: disastrous urban fires. In: Majumdar, S.K.; Forbes, G.S.; Miller, E.W.; Schmalz, R.F., eds. *Natural and technological disasters: causes, effects and preventative measures*. The Pennsylvania Academy of Science: 62–74. Chapter 6.
- Small, R.D.; Heikes, K.E. 1988.** Early cloud formation by large area fires. *Journal of Applied Meteorology*. 27: 654–663.
- Small, R.D.; Larson, D.A., Brode, H.L. 1981.** Analysis of large urban fires. PSR Report 1122 Final report contract EMW-C-0309. Arlington, VA: Pacific-Sierra Research Corporation.
- Small, R.D.; Larson, D.A.; and Brode, H.L. 1983.** Fluid dynamics of large area fires. *Proceedings of the 21st national heat transfer conference*, New York: Society of Mechanical Engineers.
- Smith, R.K.; Morton, B.R.; Leslie, L.M. 1975.** The role of dynamic pressure in generating fire wind. *Journal of Fluid Mechanics*. 68 (1): 1–19.
- Soma, S.; and Saito, K. 1991.** Reconstruction of fire whirls using scale models. *Combustion and Flame*. 86: 269–284.
- Stocks, B.J. 1989.** Fire behavior in mature jack pine. *Canadian Journal of Forest Research*. 19: 783–790.
- Sugawa, O.; Takahashi, W. 1993.** Flame height behavior from multi-fire sources. *Fire and Materials*. 17: 111–117.
- Tarr, S.J.; Allen, G. 1998.** Flame interactions. Final technical report on performance prediction in advanced coal fired boilers. Contract No. JOF3–CT95–0005. Westminster, London, United Kingdom: International Combustion Limited, Rolls Royce Industrial Power Group.
- Taylor, R.J.; Evans, S.T.; King, N.K.; Stephens, E.T.; Packham, D.R.; Vines, R.G. 1973.** Convective activity above a large-scale bushfire. *Journal of Applied Meteorology*. 12: 1144–1150.
- Thomas, P.H. 1963.** The size of flames from natural fires. *Symposium (International) on Combustion*. 9: 844–859.
- Thomas, P.H. 1968.** On the development of urban fires from multiple ignitions. *Fire Research Note No. 699*. Boreham Wood, Hertfordshire, United Kingdom: Fire Research Station.
- Thomas, P.H.; Baldwin, R.; Theobald, C.R. 1968.** Some model scale experiments with multiple fires. *Fire Research Note No. 700*. Boreham Wood, Hertfordshire, United Kingdom: Fire Research Station.
- Tieszen, S.R. 2001.** On the fluid mechanics of fires. *Annual Review of Fluid Mechanics*. 33: 67–92.

- Tolhurst, K.G.; Cheney, N.P. 1999.** Synopsis of the knowledge used in prescribed burning in Victoria. Victoria Australia: Department of Natural Resources and Environment, Fire Management.
- Trelles, J.; Pagni, P.J. 1997.** Fire induced winds in the 20 October Oakland Hills Fire. *Fire Safety Science*. 5: 911–922.
- Van Wagner, C.E. 1977.** Conditions for the start and spread of crown fire. *Canadian Journal of Forest Research*. 7: 23–34.
- Van Wagner, C.E. 1988.** Effect of slope on fires spreading downhill. *Canadian Journal of Forest Research*. 18: 818–820.
- Viegas, D.X.; Pita, L.P. 2004.** Fire spread in canyons. *International Journal of Wildland Fire*. 13: 253–274.
- Vogel, M.; Williams, F.A. 1970.** Flame propagation along matchstick arrays. *Combustion Science and Technology*. 1: 429–436.
- Wade, D.D.; Ward, D.E. 1973.** An analysis of the Airforce Bomb Range Fire. Res. Pap. SE-105. Asheville, NC: U.S. Department of Agriculture, Forest Service, Southeastern Forest Experiment Station. 38 p.
- Weatherspoon, C.P.; Almond, G.A.; Skinner, C.N. 1989.** Tree-centered spot firing—a technique for prescribed burning beneath standing trees. *Western Journal of Applied Forestry*. 4(1): 29–31.
- Weber, R.O. 1989.** Analytical models for fire spread due to radiation. *Combustion and Flame*. 78: 398–408.
- Weber, R.O. 1990.** A model for fire propagation in arrays. *Mathematical and Computer Modeling*. 3(12): 95–102.
- Weber, R.O.; Dold, J.W. 2006.** Linking landscape fires and local meteorology—a short review. *JSME International Journal*. Series B49(3): 590–593.
- Weihls, D.; Small, R.D. 1986.** Interactions and spreading of adjacent large area fires. DNA-TR-86-214. Arlington, VA: Pacific-Sierra Research Corporation. 38 p.
- Weise, D.R.; Bigging, G.S. 1996.** Effects of wind velocity and slope on flame properties. *Canadian Journal of Forest Research*. 26: 1849–1858.
- Weise, D.R.; Zhou, X.; Sun, L.; Mahalingam, S. 2005.** Fire spread in chaparral: “go or no-go.” *International Journal of Wildland Fire*. 14(1): 99–106.
- Welker, J.R.; Pipkin, O.A.; Sliepcevich, C.M. 1965.** The effect of wind on flames. *Fire Technology*. 1: 122–129.
- Welker, J.R.; Sliepcevich, C.M. 1966.** Bending of wind-blown flames from liquid pools. *Fire Technology*. 2(2): 127–135.
- Weng, W.G.; Kamikawa, D.; Fukuda, Y.; Hasemi, Y.; Kagiya, K. 2004.** Study on flame height of merged flame from multiple fire sources. *Combustion Science and Technology*. 176(12): 2105–2123.
- Williams, F.A. 1982.** Urban and wildland fire phenomenology. *Progress in Energy and Combustion Science*. 18: 317–354.
- Wood, B.D.; Blackshear, P.L.; Eckert, E.G.R. 1971.** Mass fire model: an experimental study of the heat transfer to liquid fuel burning from a sand-filled pan burner. *Combustion Science and Technology*. 4(1): 113–129.
- Woodburn, P.J.; Drysdale, D.D. 1998.** Fires in inclined trenches: the dependence of the critical angle on trench and burner geometry. *Fire Safety Journal*. 31: 143–164.
- Wotton, B.M.; McAlpine, R.S.; Hobbs, M.W. 1999.** The effect of fire front width on surface fire behavior. *International Journal of Wildland Fire*. 9(4): 247–253.
- Wu, Y.; Xing, H.J.; Atkinson, G. 2000.** Interaction of fire plume with inclined surface. *Fire Safety Journal*. 35: 391–403.

Chapter 6: Column/Plume Dynamics

Brian E. Potter¹

Introduction

“Plume dynamics” refers to the airflow related to a fire’s updraft and the way that updraft changes over time. In terms of extreme fire behavior, plume dynamics matter because they can accelerate surface winds and can bring the wind, moisture, and temperature conditions above the ground down to the ground, where the fire is. These aboveground conditions may or may not be the same as the conditions at the ground, and the differences can produce unexpected changes in fire behavior. The updraft is part of a fire-driven circulation that includes downward air motion in other areas and modifies the horizontal winds near the fire. The updraft also lifts burning embers that can ignite spot fires. Any of these can lead to nonsteady state, or for the purposes of this review, extreme fire behavior. This section examines several concepts and tools related to plume dynamics that are well known in the fire management community, noting their foundations, strengths, weaknesses, and limitations. Spot fires are addressed in more detail in chapter 7.

Over the past 40 years, several studies have reported information related to plume structure in wildland fires. These studies combined with some complementary knowledge of the structure of convective thunderstorms make it possible to create a qualitative description or idealized model of the plume and associated airflow produced by a wildland fire. This model is a simplification and does not include the transient features of a real plume, especially features that come and go on very short time scales. However, it serves as a useful foundation for discussing how plume dynamics can lead to extreme fire behavior. Before addressing specific relationships between plumes and basic or extreme fire behavior, it is necessary to briefly establish this qualitative description and its origins.

Countryman (1969) summarized the Project Flambeau experiment and the data collected there. This study involved

slash piles laid out in grids, with the intent of simulating mass ignitions following a nuclear attack. In spite of the artificial fuel loads and geometry and the fact that the fires were stationary, the observed airflow in and around the plume provides insight into natural wildland fire situations. Reid and Vines (1972) used a sequence of photographs and radar scans of a fire plume to track individual smoke turrets and infer both vertical and horizontal velocities. Taylor et al. (1968, 1971, 1973) flew aircraft through plumes on prescribed fires to measure vertical motions and temperatures in the plumes at heights up to about 3 km above ground level (AGL). Banta et al. (1992) used Doppler radar to look through smoke into the fire plume and captured detailed airflow in and around the plume. Schroeder and Buck (1970) and Goens and Andrews (1998) identified the possibility of intense downdrafts associated with plume updrafts and the potential implications of these downdrafts. Clements et al. (2006, 2007) directly measured airflow and temperature as a fire front passed instrument towers, yielding insight into the near-ground winds associated with a propagating fire.

Although these papers address fire-related plume studies, there are many more studies of thunderstorm plume dynamics in the absence of fire. There are critical differences between the two types of plumes—intensity of the energy source, horizontal movement of that energy source, and vertical distribution of the energy source, to name a few—but there are also important similarities that can provide valuable insight into fires. The understanding of storm dynamics comes from decades of expensive research that would be markedly more expensive and dangerous to perform on fire plumes, so it would be unwise and irresponsible to ignore it. (Not only can thunderstorms be more easily measured and observed, but they are also easier to simulate in computer models to identify features not directly observed.) Key publications in the storm literature include Browning (1976), Klemp et al. (1981), Foote and Frank (1983), Hobbs and Rangno (1985), Houze et al. (1989), and McCaul and Weisman (2001).

¹ **Brian E. Potter** is a research meteorologist, U.S. Department of Agriculture, Forest Service, Pacific Wildland Fire Sciences Laboratory, 400 N 34th St., Suite 201, Seattle, WA 98103.

Figure 6-1 illustrates a composite structure constructed from these various studies (this structure includes only the features most clearly observed in fire studies and/or those observed in fires as well as thunderstorm studies). The most consistently observed, best recognized characteristics are the updraft column, and the rear and lateral inflow to the fire at the ground (Countryman 1969, Palmer 1981). Less documented are the descending rear inflow and the accelerating character of the updraft. These have been observed (Banta et al. 1994; Clements et al. 2006, 2007) and are consistent with both basic fluid mechanics and the storm literature, but they are more difficult to observe, and details of their character are very poorly known. This descending rear inflow is not the same as the downbursts discussed by Schroeder and Buck (1970) or Goens and Andrews (1998)—those are more intense, short-lived, and localized currents, while the descending rear inflow appears to be a persistent and moderate speed feature. The updraft may consist of a sequence of puffs or turrets that separate from the fire front and move downwind (Reid and Vines 1972). These successive turrets (each one an updraft) could move forward or backward relative to the fire, but typically move forward. Stability of the atmosphere also influences the

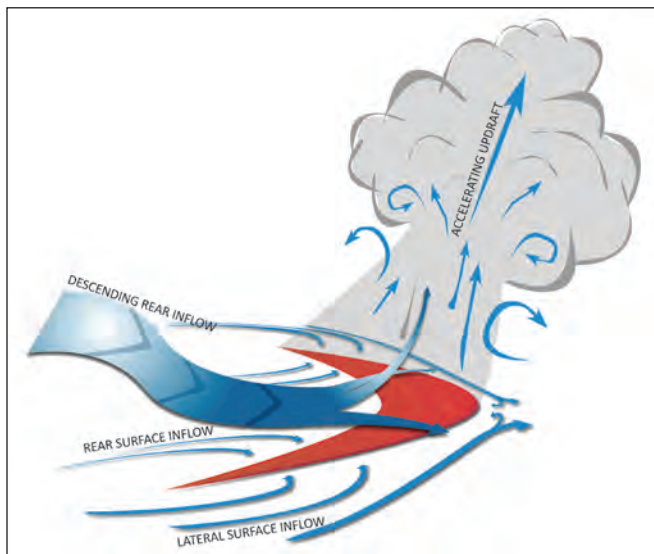

Figure 6-1—Conceptual model of the airflow in and around a fire's plume (This structure includes only the features most clearly observed in fire studies or those observed in fires as well as thunderstorm studies).

acceleration and magnitude of the updraft, with an unstable atmosphere allowing stronger, deeper updrafts. The wind profile influences the inclination of the updraft, its strength, and the relative forward motion of the turrets compared to the fire front.

Plume-Dominated and Wind-Driven Fires

The most recognized connection between extreme fire behavior and plume dynamics is the concept of a plume-dominated or wind-driven fire. Generally, wind-driven fires are more predictable because the fire spreads with the wind (Bryan 1959). When someone labels a fire “plume-dominated,” it is because the smoke plume is standing almost vertically and there is little visible influence of the horizontal wind on the fire. In common usage, the implication is that the fire's behavior may change rapidly and that the fire's direction of spread could change unexpectedly.

Byram's original presentation did not provide any derivation, but Nelson (1993) did so based on Nelson's conversations with Byram and Byram's own notes on the equations. Nelson's derived forms and Byram's original forms differ slightly, with Byram's equations having units of mass per distance per unit time (or as Byram stated, foot pounds per second per square foot) and Nelson's having units of mass per unit time cubed. Units aside, both authors actually emphasize the use of what they call the convection number, N_c , which is the ratio of the power of the fire to the power of the wind—the units cancel out and both authors' equations for N_c are the same:

$$N_c = \frac{2gI}{\rho c_p T_0 (v - r)^3}$$

where g is the gravitational acceleration (9.8 m/s^2), I is the fire intensity per unit length of the fire front (Joules per second per meter), ρ is the density of air (kilograms per cubic meter), c_p is the specific heat of air (Joules per kilogram per degree Celsius), T_0 is the environmental temperature of air at the ground (Kelvins, equal to degrees Celsius plus 273), v is the horizontal windspeed (m/s), and r is the fire rate of forward spread (m/s). The power equations and the equation for N_c assume a neutrally stable atmosphere. Nelson (1993) provides

a brief discussion of how an atmosphere that is not neutrally stable and mixing of plume air with the environment affect the equations, and Nelson (2003) expanded on these two points.

Byram (1959) provided one example of applying the power equations to an actual fire, using the Wood River Valley Fire in May 1951 in Rhode Island. He stated:

The energy criterion cannot give directly any information as to what [power of the fire dominating power of the wind and an inferred three-dimensional structure] means in terms of specific fire behavior characteristics, but the case studies can. These studies have shown that extreme fire behavior and blowup characteristics occur when $P_f > P_w$ for a considerable height above the fire—usually at least 1000 feet and more, often greater than 3000 or 4000 feet. Possibly one of the most erratic conditions is in the transition zone where P_f and P_w are nearly equal.

He presents a valuable discussion of the evolution of a wildland fire in terms of these powers. He rightly observes that for every fire, P_f starts out small. For intensity and P_f to increase, he states moderate to high surface winds are necessary to fan the flames. However, it is plausible that terrain or fuels could contribute to increasing intensity even without high surface winds. Regardless of what causes intensity and P_f to increase, they may grow to exceed P_w over a layer of the atmosphere deep enough to create a “chimney or convection column” over the fire.

Wade and Ward (1973) considered N_c in their study of the 1971 Air Force Bomb Range fire in North Carolina. They noted that computing N_c required several assumptions, including neutral stability, no long-distance spotting, and “adequate data on fuels, weather and fire behavior.” Making these assumptions, they determined that N_c exceeded a value of 1 from the surface to just below 300 m AGL during the period of the fire’s major run and as it increased, so did rate of spread. Their calculations for the peak spread period indicated N_c greater than 1 up to 2000 m AGL with the exception of the layer between 300 to 900 m AGL. The highest value of N_c in their analysis was approximately 4.6,

at the surface during the peak spread period. The highest value of N_c in the layer from 900 to 2000 m AGL was 1.4, at 1500 m.

Applying the necessary assumptions forced Wade and Ward to contradict other evidence from the fire. For example, the assumption of neutral stability contradicts their observations of an unstable atmosphere reaching up to 2300 to 2700 m AGL during the day. Instability would combine with the fire’s energy output to increase P_f and therefore N_c . Including the impacts of instability would thus have increased N_c during the daytime, most likely amplifying the changes Wade and Ward observed in N_c during the fire’s blowup period.

The assumption of no long-distance spotting contradicts their narrative summary of the fire’s behavior, as well as their centerpiece figure illustrating the fire’s spread by spotting. It is not clear why Wade and Ward state that the calculation of N_c requires assuming no long-distance spotting; Byram’s sole claim about N_c was that fire behavior became more erratic when N_c is close to 1 and more extreme when N_c is greater than 1, but spotting does not necessarily contradict that claim. Strong spotting does increase the effect of wind on fire spread, but spotting is also enhanced by greater lofting in a strongly developed convection column—which would result from high P_f . The end result is that spotting and its potential role in rapid fire spread (i.e., extreme fire behavior) make N_c a less helpful tool for extreme fire behavior prediction.

Simard et al. (1983) applied Byram’s P_f and P_w calculations as part of their case study for the 1980 Mack Lake Fire. They found that during the period of most rapid spread, P_f exceeded P_w up to at least 1300 m AGL. (The lowest value for the convection number, N_c , between the ground and that height was 2.4.) Like Wade and Ward (1973), Simard et al. had to make numerous assumptions about the weather. They assumed, for example, that the wind profile was constant over time, though the surface observations and regional variations in the vertical wind profile suggest quite a bit of variability. The winds used in their calculation of P_w are actually the highest winds observed at given levels, and any other windspeeds would have substantially reduced P_w .

Aronovitch (1989) applied Byram's equations to two fires, the Sundance Fire from 1967 and the Butte Fire of 1985. For the Sundance Fire, Aronovitch's treatment of wind variability with height is unclear. The one figure depicting N_c shows no height dependence, only a time series, and this indicates N_c greater than 1 for several hours during the fire's major run. Aronovitch's calculations show N_c near 20 at 1500 Local Standard Time (LST), then dropping sharply to near 1 at 1700 LST and remaining between 0.02 and 2.8 for the remainder of the period. Aronovitch's calculations of fire intensity and narrative of the run show the peak growth between 2000 and 2300 LST, including the comment "fire storm" at 2000 LST—but N_c peaks at 1500 LST and is only 1.7 at 2000 LST. If N_c directly indicates "blow up" fire conditions, it did not work in this instance. For the Butte Fire, Aronovitch examined N_c (as the two components, P_w and P_f) using two different values of P_f —one "prior to blow up" and the other "after blow up." Using the "prior" P_f , N_c exceeds 1 between approximately 150 and 1100 m. Using "after" P_f , N_c exceeds 1 from the ground to 1400 m above the fire. For both values of P_f , the peak value of N_c occurs at 60 m above the fire, where P_w drops to less than 0.2, yielding N_c of 20 (prior) and 60 (after). It is a circular argument, however, to say that when the fire was most intense ("after," according to Aronovitch's narrative), it was most powerful—for management purposes, the simple knowledge that the fire's intensity more than tripled between the two periods provides as much insight as the more detailed calculation (requiring many more assumptions) of N_c .

Rothermel (1991) incorporated Byram's equations into his model for predicting behavior and size of crown fires in the Northern Rockies. The nomogram calculations of P_f and P_w do not influence any other calculations in this crown fire system, rather their comparison is used to suggest the possibility of a plume-dominated fire. In incorporating them, however, Rothermel had to rely solely on winds measured at 6.1 m above canopy and could not require any further information on vertical variations in windspeed. This and the fact that the nomograms are only available for fuel types in the Northern Rockies lead to limitations in the application of the crown fire behavior calculations. (Only one of the

four fires discussed in the aforementioned studies, the Butte Fire, was in the Northern Rockies.)

Byram's equations, or Nelson's more general equations, represent the energy produced by combustion and that contained in the wind field. Application of the equations for case studies has a very low precision. Small uncertainty (or errors) in determining the windspeed or the rate of spread, especially when they are comparable, can lead to very large uncertainty (or errors) in P_w and N_c because the difference in windspeed and fire rate of spread is cubed and because this difference appears in the denominator of N_c .

The scientific strength of any claimed relationship between P_f , P_w , or N_c and fire behavior suffers from an additional, very important limitation. To truly be meaningful in indicating potential for "extreme fire behavior and blowup characteristics," it is important to not only show that this behavior has happened when $P_f > P_w$, but to also show that the behavior does not happen when $P_f < P_w$. This cannot be done by looking only at blowup fires, it requires application of a uniform computation of P_f and P_w for a large set of random fires, some of which showed extreme behavior and others that did not. Similarly, there is no published study considering whether $P_f > P_w$ guarantees extreme fire behavior, or what proportion of the time this might be true. Byram's statement that fire behavior is possibly most erratic when P_f and P_w are nearly equal makes any analysis still more challenging.

With respect to operational use, obtaining the necessary data to apply the equations is a daunting task. Aronovitch simplified the application somewhat by assuming density, specific heat, and gravity are constant. Rothermel (1991) went one step further and specified temperature at 80 °F (40 °C). The remaining unknowns are windspeed, fire intensity, and rate of spread. The two fire measures can be obtained, either for current or future conditions, from observations or a model like BEHAVEPlus. They depend solely on surface conditions. To allow proper calculation and application of N_c , windspeed must be known as a function of height. (The inconsistency of assuming constant winds over height with Byram's adverse wind profiles is discussed in the next section.) Because of high variability across the landscape, especially in rugged terrain, and the importance of changes

over time, this is perhaps the most difficult information to obtain—and yet, it is arguably the most critical because it is cubed in computing N_c . Current weather forecast models provide information on a scale down to 1.3 km, at the very best, and finer resolution models typically only provide surface windspeeds. These challenges may explain why there are no reports of Fire Behavior Analysts applying N_c , P_f , or P_w in an operational context. Although the NWCG S-490 stated objectives include estimation of P_f and P_w , there is no quantitative exercise or explicit discussion of estimating these, and it is not listed in the instructor handbook among the topics to be tested.

Adverse Wind Profiles and Low-Level Jets

Closely related to the power of the fire and the power of the wind is Byram's other well-known contribution to the science of extreme fire behavior, the idea of the "adverse wind profile" (Byram 1954). This is often simply referred to as the "low-level jet." Byram's adverse profiles or the low-level jet concept are taught in all of the NWCG fire behavior classes, and are cited in numerous case studies.

This paper discusses turbulence, instability, and the jetstream's location in addition to wind profiles, but it is the wind profiles that remain widely known. Byram examined the wind profiles measured near 17 fires. He identified eight wind profile types he felt indicated various degrees of blowup potential, associating as many as four profile types with individual fires.

The technique Byram used is extremely important. He truncated the soundings at the height of the fire when the sounding location elevation was lower than the fire elevation, and for cases where the fire occurred below the height of the sounding base, he simply raised the sounding and left the lower portion blank. In doing this, many of his "jets" that occurred at higher elevations appear to be closer to the ground. For example, Byram used observations from Great Falls, Montana (elev. 1100 m) for the Mann Gulch Fire (estimated elev. 1700 m) and so any jet present in that sounding appears 580 m closer to the surface than it actually was observed. Similarly, the "surface" wind cited for the McVey Fire was actually observed at 640 m above the ground at

Rapid City, South Dakota. He includes the full soundings at the end of the paper, but these appear to have been largely ignored in his and others' subsequent discussion of his work. Excluding the effects of stability and terrain makes it impossible to know whether the atmosphere would flow over or around terrain, and therefore whether it would have been more appropriate to assume the ground-level winds at the observation site were also the ground-level winds at the fire site, or to truncate the soundings as he did.

One feature Byram mentioned has been largely forgotten. He states "The direction profile is an extremely important part of the complete wind profile" and provides the full wind direction profiles for each case he examined—without truncation, but he does not provide any discussion or explanation of how the directional profiles may have influenced the case studies, or exactly how they were important. The figures show a variety of directional profiles, as well as changes in those profiles during the fires.

Steiner (1976) raised the question of what physical process might explain the role of a low-level jet in blowup fires. While the discussion centered on momentum, convergence, and divergence and how they affect the fire column, it was in general terms and did not reach any particular conclusions.

Brotak (1976) considered Byram's low-level jet along with a variety of other atmospheric measures in examining 62 "large and extremely serious" wildfires. These fires were predominantly in the Eastern United States. Brotak's criterion for a jet was a windspeed 2 m/s greater than that 300 m above or below it. Overall, only one third of the fires considered displayed such a jet.

Even disregarding the concerns noted above about the truncation of the soundings used by Byram, nothing is known about how often a low-level jet is present at times when a fire does not behave erratically or blowup. This is essential for knowing what the false alarm rate might be, or whether the low-level jet might be a regular feature in some parts of the country.

The low-level jet seen in Byram's most dangerous profiles directly repudiates the use of height-invariant winds to compute P_w , noted in the previous section. Using such

winds assumes no jet, underestimates P_w , and therefore underestimates the value of P_f necessary to yield $N_c > 1$. As noted earlier, because the windspeed is cubed in computing P_w , small errors in the windspeed produce larger errors in P_w . There is no published study applying both Byram's P_f , P_w , or N_c , and his adverse wind profiles to a common set of fires.

Presently, the only operational application of the Byram wind profiles is subjective assessment of observed profiles by fire behavior analysts or incident meteorologists. If Byram's truncation technique is not problematic and the low-level jet primarily occurs on blowup fires, then this assessment is appropriate. However, if the technique misrepresented the winds over the actual fires or the jet occurs on many days, with or without blowup fires, then the assessment provides no real insight and may lead to a misperception of the actual risk of extreme fire behavior.

Stability and Instability

Few who currently work with wildland fires doubt that there is a connection between atmospheric stability and fire behavior. The concept first appears in Foley (1947) followed by Crosby (1949), Byram and Nelson (1951), and Davis (1969), and several other, less pivotal papers. These papers discussed the relationship in general terms but were not scientific studies. Davis (1969) examined stability accompanying 70 fires in Arkansas, Alabama, Louisiana, Mississippi, and Tennessee using broad stability and fire size classes. Later, Brotak and Reifsnyder (1977) found that unstable air above a fire was present for a number of large fires. Haines (1988a) used these observations as the basis of his Lower Atmospheric Severity Index, now known widely as the Haines Index. More recently, Potter (2002) discussed how atmospheric stability may reflect the potential circulation created by a fire, which includes the winds at the surface influencing fire behavior.

A stable atmosphere resists the rising motion of hot air in the fire's plume and saps some of the energy from that air in doing so. In contrast, an unstable atmosphere supports vertical movement of air, promoting general mixing of air between the ground and regions higher up even when no fire is present. Instability itself cannot directly influence the

combustion process—it must be converted into wind to do this. Instability (a form of potential, or stored, energy) can be converted into an organized circulation including the fire's updraft, on a scale of a kilometer or more, or it may produce turbulent wind energy on scales down to meters or tens of meters. Even in the absence of a fire, strong instability promotes mixing and turbulence and can bring air aloft down to the ground where it can interact with fuels and any combustion that does occur. For a given fire at a given time, all of these processes can be occurring simultaneously. Instability cannot directly start a fire, either. It can foster thunderstorms that produce lightning, but that is an indirect connection and is not related to extreme fire behavior.

Foley (1947), Crosby (1949), and Byram and Nelson (1951) all postulated that instability influences fire behavior primarily through the turbulence and high winds it can transport downward to the fire. They did not differentiate between mixing resulting from the instability alone and mixing resulting from the fire's interaction with instability. Because terrain and surface features like lakes, rivers, and changes in vegetation can promote mixing, it would be very difficult to determine whether ambient mixing or fire-induced mixing plays a stronger role. In any case, the instability enables it, and there is a straightforward physical explanation of at least one way instability can contribute to extreme fire behavior.

Brotak and Reifsnyder (1977), Haines (1988a), and Potter (2002) all included some measure of moisture aloft in their discussions of instability. Brotak and Reifsnyder (1977) found a correlation between low moisture aloft and large fire occurrence at the ground, which led to the inclusion of this element in the Haines Index and suggested it may be important for the circulation considered by Potter (2002). Because of this mixture of moisture and stability—and the intrinsic physical influence of moisture on stability—one must be careful in interpreting the results or implications of these research studies.

Davis (1969), Brotak and Reifsnyder (1977), and Haines (1988a) did not examine extreme fire-behavior qualities—intensity, rate of spread, or flame length. Rather, Davis considered stability at the times of fires over 120 ha (300 ac) provided to him by state fire control staff. Brotak and

Reifsnnyder looked at atmospheric properties present at the time of “large” fires, defined as larger than 2000 ha. Haines’ fire data set included 74 fires reported by wildland fire management units as “their worst situations over 20 [years].” How to translate these fire characteristics to the concept of extreme fire behavior, if it is even possible to do so, is not clear. At present, the Haines Index is the only quantitative measure of stability used in wildland fire management.

There are questions of scale and the role moisture plays in interactions between stability or instability and fire. Nonetheless, the use of the Haines Index to indicate the regional potential for fires to display erratic behavior is consistent with its derivation. There are other stability indices used for thunderstorms (such as the K, Lifted, Showalter, SWEAT, and the Total Totals Indices) or smoke dispersion (such as the Lavdas Atmospheric Dispersion Index), but none of these have been scientifically evaluated for use in predicting extreme fire behavior, or fire behavior of any kind.

Much remains unknown about instability’s influence on extreme fire behavior. Is it possible to differentiate instability’s influence on plume strength (and subsequently ground-level inflow winds) from the relationship between instability and turbulence? Heilman and Bian (2010) showed that multiplying the Haines Index by the surface turbulent kinetic energy differentiates fires bigger than 400 ha from smaller fires better than just the Haines Index does alone. This suggests that it is indeed the turbulence generated by the instability that matters for fire size, but does not rule out plume strength as an additional contributing factor. In addition, the questions noted above regarding moisture interactions with instability and which measures of fire behavior are influenced by instability are subjects needing further research. While answers to these questions may prove useful from an operational perspective there is sufficient evidence of instability’s ties to extreme fire behavior to justify great caution when unstable conditions exist.

Downbursts and Plume Collapse

In meteorology, a downburst is both a broad description of a family of related phenomena and a specific member of

that family. The fire behavior community generally uses the broader definition, “an area of strong, often damaging winds produced by a convective downdraft over an area from less than 1 to 400 km in horizontal dimensions” (Allen Press 2000). The physical processes driving a downburst come fundamentally from the condensation and evaporation of moisture in the plume, but depend as well on the vertical wind profile. There must be sufficient moisture in the convective updraft to produce rain droplets, snow, and hail. The updraft must lift the precipitation to a height where there is a deep layer of dry air beneath it. The updraft must lean over enough so that when the precipitation falls, it does not fall directly down into the updraft but falls into the dry air—either to the side of the updraft or else beneath the base of the cloud. Details of the downburst process can be found in Houze (1993) and other books describing the dynamics of severe storms.

The term “plume collapse” (sometimes called column collapse) evokes vivid images of towering smoke plumes roiling upward and then falling back towards the ground. There is no official definition in the fire community for plume collapse, nor does there appear to be any generally agreed upon standard. The idea of plume collapse is taught in S-290 and in more detail in S-390, but there is no single stated definition in those curricula, nor is there a definition in the NWCG Glossary of Wildland Fire Terminology. The S-390 precourse work still references the *Fire Weather Handbook* (Schroeder and Buck 1970) that includes a discussion of the air mass thunderstorm concept presented above, suggesting that is the intended use of the term for wildland fire management.

For the present synthesis, plume collapse is a special case of a downburst. In plume collapse, the energy source is cut off or ceases, and the updraft decays or reverses in motion, producing a downburst. A downburst, more generally, is a downdraft that occurs near the continuing updraft, **not necessarily including the loss of the driving energy source or the cessation of the updraft.** This definition of plume collapse is compatible with the equivalence of plume collapse and dissipating convection in the current S-390 course.

At the ground, the symptoms of a downburst are a sudden but brief period where the wind subsides, followed by a sudden gust of winds radiating out from the center of the sinking air. There may be precipitation at the ground or signs of precipitation aloft, such as virga. The area underneath the precipitation is the most likely candidate for the center of the sinking air. Air temperatures may drop suddenly at the ground, but this may be difficult to detect near a fire and will occur at the same time as the arrival of the wind gust. Rothermel (1991) notes,

Another indicator [of a downburst] is the rapid development of a strong convection column above the fire, or nearby thunder cells. This is a poor indicator because all crown fires have a convection column located above them in some form, and a person beneath the cell cannot see its vertical development; but observers around the fire periphery could call attention to any large column growing vertically above the fire front.”

The column development Rothermel mentions is the precursor to the downburst, it is the strong updraft that can produce and lift the necessary precipitation that may then fall and produce the downburst.

Downbursts associated with fire behavior appear in the fire literature going back to Cramer (1954)—though this paper calls them thundersqualls. Here and in the references to downbursts in Schroeder and Buck (1970) and Haines (1988b), the discussion focuses on downbursts generated by nearby thunderstorms—not by the fire column itself. Haines (1988b) noted that downbursts with heavy precipitation are more common in the Eastern United States, labeling them “wet downbursts.” Dry downbursts, in contrast, are more common in the arid regions of the United States where the precipitation may evaporate before reaching the ground. Downbursts generated by convection separate from the fire’s plume may be easier to anticipate because spotters can see the thunderstorm directions more clearly, but they can also be more difficult to anticipate if thunderstorms are numerous and widespread.

Goens and Andrews (1998) hypothesized that the fatalities on the Dude Fire in 1990 resulted from a downburst that

drove the fire behind the retreating fire crew. They presented both fire behavior observations and meteorological observations consistent with the development of a downburst. While “consistent with” is not the same as “definitively identified,” their analysis presented stronger evidence than many other claims that have made their way into wildland fire lore. The observations included light precipitation at the ground, a strong convection column, and a calm just before the downburst. The downburst, when it came, brought winds of 20 to 30 m/s and lasted only a few minutes. In this instance, topography added to the danger of the downburst. The air in a downburst is denser than the air around it, and so it will flow downhill. If that flow runs into the fire, it will carry the fire downhill at speeds more typical of an uphill run. In support of their analysis, Goens and Andrews showed the local temperature and moisture profiles at the time of the downburst. The hot, dry air extending upwards to 500 mb shows clearly the conditions that can yield a dry downburst, whether from a thunderstorm or fire plume.

The only reference to plume (column) collapse in the scientific literature on wildland fires is Fromm and Servranckx (2003). They referred to the Chisolm Fire in 2001, and the use of the term “convective collapse” is not clarified; it appears to mean the plume top, which had been well above the tropopause, sank down to be closer to the tropopause. Because the reported surface winds at this time during the fire were between 30 and 50 km/h, the top of the convective plume would have been well downwind of the fire when this occurred, and the event does not qualify as plume collapse under the definition stated above. In addition, while this and the “collapse” of other tropopause or inversion-penetrating fire plumes are well documented, there is no evidence that their collapse at the top led to fire behavior changes at the ground.

Without additional scientific papers examining the influence of plume collapse on fires, the extent or existence of the process is a legitimate subject for debate. The air mass thunderstorm model presented in the *Fire Weather Handbook* (USDA 1970) is still used in meteorology, but only as an idealized model. It requires a decrease in the

energy feeding the storm cell with precipitation subsequently falling straight back into that updraft—this will not occur if there is any significant wind shear. When it does occur, it marks the end of the storm, and after the brief surge in surface winds, the event is over. If this type of energy cutoff were to occur on a wildland fire and cause extreme fire behavior, there would presumably be documented observations that the fire’s plume was destroyed at the time or the plume would have to have separated from the energy source. The present review of scientific literature did not yield any descriptions of such events associated with extreme behavior on wildfires.

Plume collapse in a low- or no-wind situation may be relevant to broadcast burning situations. Those events would typically occur with light winds (less than about 8 km/h), with concentrated fuels, and would produce nearly vertical columns. The energy output drives the updraft, which in turn produces the converging winds at the surface. As the energy output diminishes, so do the surface winds. At some point, although the energy output has not dropped to zero, the natural stability of the atmosphere will inhibit the updraft to the point that any embers or other debris that were held aloft by the updraft will fall back to the ground. Concurrently, the inflow of winds at the base will diminish and the smoke still produced by the low-intensity burning will stop being drawn inward and upward, and will remain near the ground. No further “collapse” or downward rush of air is necessary, though it may occur.

Foote and Frank (1983) and Yang and Houze (1995) described the separation of storm updrafts from the leading edge of the storm (roughly analogous to the fire front), with new updraft cells forming at the leading edge as old, now detached cells drift rearward (fig. 6-2) Conceivably these detached cells, now deprived of their energy source, would dissipate in a way that would produce winds and ember showers similar to those attributed to plume collapse—even though the main plume at the fire front is still robust. Drawing analogies between fires and storms requires caution, as noted earlier. For example, while separated cells are often observed on fires (e.g., Banta et al. 1994, Reid and Vines

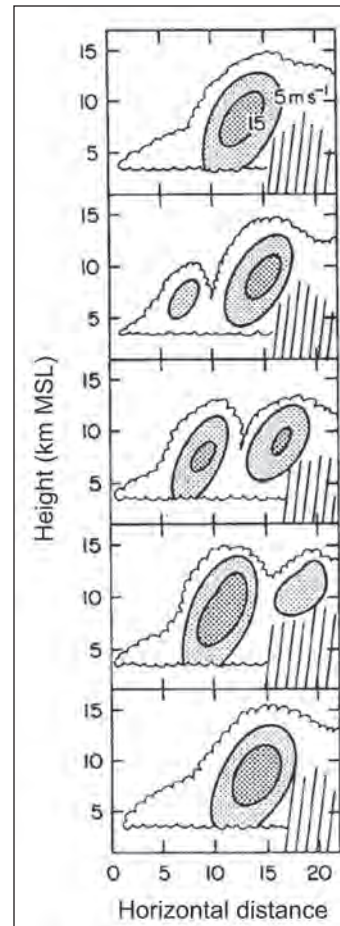

Figure 6-2—Evolution of updraft cells in multicell thunderstorm. The storm is moving from right to left. Frames progress in time from top to bottom. Source: Foote and Frank (1983).

1972), they are typically downwind of the fire instead of upwind (fig. 6-3). This would significantly alter their possible influence on fire behavior.

Clearly the processes involved in plume collapse are not known, but this does not negate the importance of the observations frequently attributed to plume collapse—first-hand observations of showers of embers, increasing smoke, or sudden changes of wind and fire spread are not in question. Many people have observed these phenomena. What is questionable or unknown is what precursors or processes caused these things to happen, whether they in any way relate to the idea of plume collapse as defined here, or what factors control the timing and location of these processes.

Haines (1988b) listed several fires where thunderstorm downbursts were considered responsible for firefighter fatalities and extreme fire behavior. The Dude Fire study by

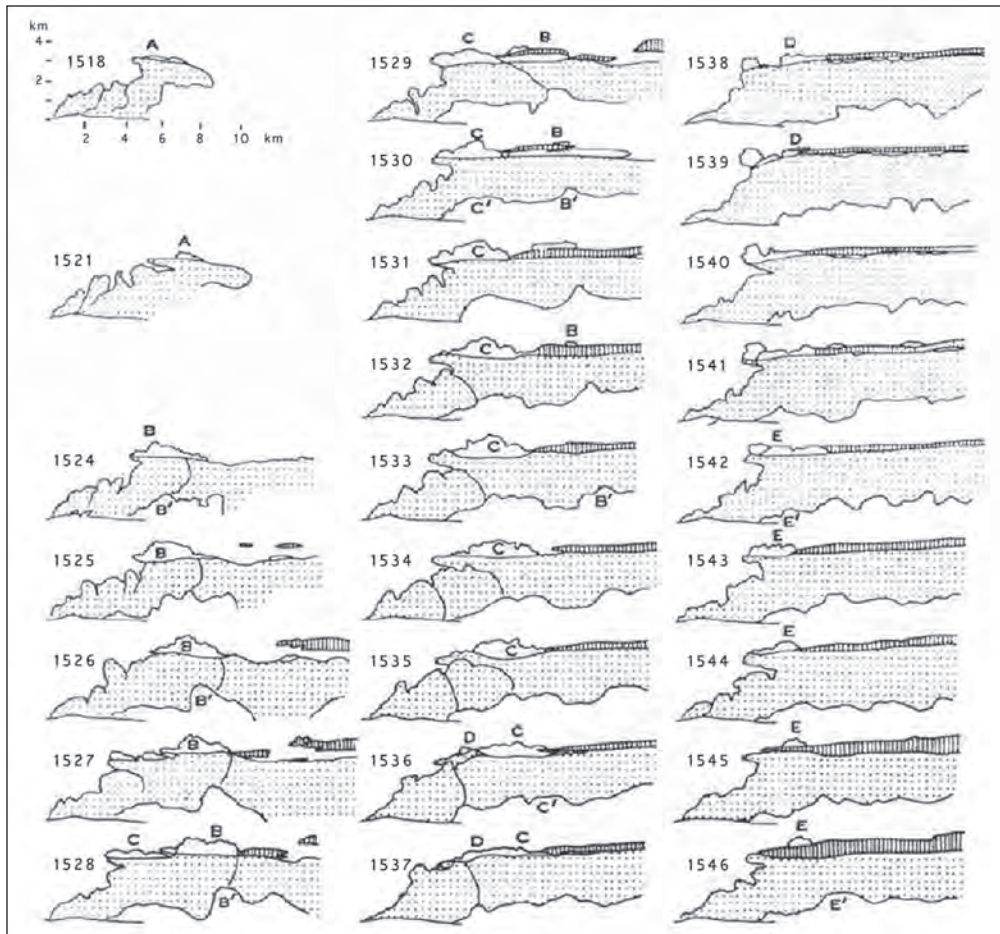

Figure 6-3—Progression of smoke plumes away from fire front (the fire is on the left side of the figure). Source: Reid and Vines (1972).

Goens and Andrews (1998) appears to be the only fire case study specifically documenting a downburst created within the fire's plume. There is no doubt that downbursts can cause extreme fire behavior.

Unresolved scientific questions about downbursts do not concern whether they occur or can cause extreme fire behavior. Nor is it particularly important from an operational perspective to determine whether fire plumes actually collapse. The useful and interesting questions about downbursts center on understanding when conditions favor the occurrence of downbursts and whether those conditions can be predicted. At the least, dry downbursts require a deep, dry layer of air near the surface at the same time they require sufficient rising air and moisture to produce the necessary precipitation. The vertical wind profile interacts

with temperature and moisture in complex ways, and while it influences the strength of the updraft and convection (McCaul and Weisman 2001) somewhat, it has a greater influence on where any downdraft occurs, relative to the updraft. The latter question is more difficult to answer, and of limited value for operational purposes—if downdrafts are possible at all, extreme fire behavior is also possible. As for wet downbursts, Haines (1988) noted that “the wet downburst will be a difficult problem for some time to come” and this is still true.

While there is no scientific study of plume collapse (as defined here) in wildland fires, management anecdotes and physics both support it as a sound explanation for some situations, notably occasions when the fire's energy output ceases or drops off rapidly, such as slash burns. The stated

significance of plume collapse in the NWCG fire behavior courses, and the fact these courses include outdated scientific models of storm behavior, bespeaks the importance of answering these questions.

Furthermore, the multiple uses, ambiguity, and strong imagery inherent in the phrase “plume collapse” are problematic. The multiple communities using the term in different ways creates potential for confusion. Eliminating the term “plume collapse” in the context of fire behavior and just discussing “downbursts” could reduce confusion.

Operationally, the science behind downbursts suggests that fire managers and forecasters need to pay close attention to local forecasts for thunderstorm potential, and assume that any time there is a thunderstorm in the region, there is potential for a downburst from that storm or the fire’s plume to influence fire behavior. Individuals engaged in operations at the fireline cannot see the early warning signs of a potential or developing downburst—all, vigorous convection column, virga, or strong surface winds bending surrounding vegetation as they approach—and therefore must rely on lookouts who can see those signs.

Summary

The winds associated with a fire’s plume influence fire behavior on both short and long time scales. The influence also varies along the fire front at any given time. Research clearly shows that these winds depend on the vertical temperature, wind, and moisture profiles of the atmosphere. Furthermore, there is strong scientific support for the notion that certain profiles, when combined with a fire’s intensity, produce what this synthesis defines as extreme fire behavior.

The scientific literature does not provide enough information or insight to allow reliable quantitative relationships or tools for determining when or to what degree extreme fire behavior might occur. The Haines Index provides an indication of regional potential, but is untested on smaller spatial scales or timeframes shorter than a day. Byram’s adverse wind profiles and power equations, however, are not practical for operational use, and too sensitive to the assumptions necessary to use them, to be helpful.

There are many unanswered questions related to plume dynamics’ effects on fire behavior. These range from the basics of how fire intensity and surface winds interact to the complex interactions of vertical temperature, wind, and humidity profiles. Are there truly “adverse” wind profiles? What types of profiles are most conducive to downbursts from fires? Is it possible to document and measure cases of plumes collapsing on wildfires? In a more applied vein, one could attempt to rigorously validate Byram’s convective number, including examining its false alarm rate.

Operationally, use of even the qualitative relationships between plume dynamics and extreme fire behavior is limited by the need to know the three-dimensional structure of the atmosphere. How that structure varies across the fire and how it is changing with time are also important. This means practitioners must either have intuition that allows them to artfully understand and predict the dynamic nature of the atmosphere in three dimensions, or else they must have access to numerical model data that tell them what that structure is.

This is not to say that there is no practically valuable understanding of plume dynamics and extreme fire behavior. Even the highly simplified model presented at the beginning of this chapter, combined with modest and approximate information on wind and moisture profiles can be valuable. For example, a pi-ball sounding can reveal wind variations in the lowest 1 to 3 km of the atmosphere, which can indicate possible gusts and runs by the fire. Similarly, elevated cloud bases and a bright white smoke plume (indicating high moisture) can warn of possible downburst potential. These sorts of general ideas are already taught in fire behavior classes and could be expanded.

Literature Cited

- Allen Press. 2000.** American Meteorological Society glossary of meteorology. 2nd ed. <http://amsglossary.allenpress.com/glossary/browse?s=d&p=43>. (16 February 2012).
- Aronovitch, B.B. 1989.** Forecasting wildfire “blow-up.” In: Proceedings, 10th conference on fire and forest meteorology. Boston, MA: American Meteorological Society and Society of American Foresters: 391–399.

- Banta, R.M.; Olivier, L.D.; Holloway, E.T.; Kropfli, R.A.; Bartram, B.W.; Cupp, R.E.; Post, M.J. 1992.** Smoke-column observations from two forest fires using Doppler LIDAR and Doppler radar. *Journal of Applied Meteorology*. 31: 1328–1349.
- Brotak, E.A. 1976.** A synoptic study of the meteorological conditions associated with major wildland fires. New Haven, CT: Yale University. 174 p. Ph.D. dissertation.
- Brotak E.A.; Reifsnnyder, W.E. 1977.** An investigation of the synoptic situations associated with major wildland fires. *Journal of Applied Meteorology*. 16(9): 867–870.
- Browning, K.A.; Fankhauser, J.C.; Chalon, J.-P.; Eccles, P.J.; Strauch, R.C.; Merrem, F.H.; Musil, D.J.; May, E.L.; Sand, W.R. 1976.** Structure of an evolving hailstorm. Part V: Synthesis and implications for hail growth and hail suppression. *Monthly Weather Review*. 104: 603–610.
- Byram, G.M. 1954.** Atmospheric conditions related to blowup fires. Station Pap. 35. Asheville, NC: U.S. Department of Agriculture, Forest Service, Southeastern Forest Experiment Station. 34 p.
- Byram, G.M. 1959.** Forest fire behavior. In: Davis, K.P., ed. *Forest fire control and use*. New York: McGraw Hill: 90–123.
- Byram, G.M.; Nelson, R.M. 1951.** The possible relation of air turbulence to erratic fire behavior in the Southeast. *Fire Control Notes*. 12(3): 1–8. (Republished in *Fire Management Today*. 63(3): 46–51.)
- Clements, C.B.; Potter, B.E.; Zhong, S. 2006.** In situ measurements of water vapor, heat, CO₂ fluxes within a prescribed grass fire. *International Journal of Wildland Fire*. 15: 299–306.
- Clements, C.B.; Zhong, S.; Goodrick, S.; Li, J.; Potte, B.E.; Bian, X.; Heilman, W.E.; Charney, J.J.; Perna, R.; Jang, M.; Lee, D.; Patel, M.; Street, S.; Aumann, G. 2007.** Observing the dynamics of wildland grass fires: Fireflux—a field validation experiment. *Bulletin of the American Meteorological Society*. 88(9): 1369–1382.
- Countryman, C.M. 1969.** Project Flambeau: an investigation of mass fire (1964–1967): final report. Berkeley, CA: U.S. Department of Agriculture, Forest Service, Pacific Southwest Forest and Range Experiment Station. 68 p.
- Cramer, O.P. 1954.** Recognizing weather conditions that affect forest fire behavior. *Fire Control Notes*. 15(2): 1–6.
- Crosby, J.S. 1949.** Vertical wind currents and fire behavior. *Fire Control Notes*. 10(2): 12–15.
- Davis, R.T. 1969.** Atmospheric stability forecast and fire control. *Fire Control Notes*. 30(3): 3–4.
- Foley, J.C. 1947.** A study of meteorological conditions associated with bush and grass fires and fire protection strategy in Australia. Bulletin No. 38. Melbourne, VIC: Commonwealth of Australia Bureau of Meteorology. 234 p.
- Foote, G.B.; Frank, J.W. 1983.** Case study of a hailstorm in Colorado. Part III: airflow from triple-Doppler measurements. *Journal of the Atmospheric Sciences*. 40: 686–707.
- Fromm, M.D.; Servranckx, R. 2003.** Transport of forest fire smoke above the tropopause by supercell convection. *Geophysical Research Letters*. 30(10): 41–1 through 49–4.
- Goens, D.W.; Andrews, P.L. 1998.** Weather and fire behavior factors related to the 1990 Dude Fire near Payson, Arizona. In: *Proceedings, 2nd symposium on fire and forest meteorology*. Boston, MA: American Meteorological Society: 153–158.
- Haines, D.A. 1988a.** A lower atmospheric severity index for wildland fires. *National Weather Digest*. 13: 23–27.
- Haines, D.A. 1988b.** Downbursts and wildland fires: a dangerous combination. *Fire Management Today*. 49(3): 8–10.
- Heilman, W.E.; Bian, X. 2010.** Turbulent kinetic energy during wildfires in the North Central and Northeastern US. *International Journal of Wildland Fire*. 19(3): 346–363.

- Hobbs, P.V.; Rangno, A.L. 1985.** Ice particle concentrations in clouds. *Journal of the Atmospheric Sciences*. 42: 2523–2549.
- Houze, R.A., Jr. 1993.** Cloud dynamics. San Diego, CA: Academic Press. 573 p.
- Houze, R.A., Jr.; Rutledge, S.A.; Biggerstaff, M.I.; Smull, B.F. 1989.** Interpretation of Doppler-radar displays in midlatitude mesoscale convective systems. *Bulletin of the American Meteorological Society*. 70: 608–619.
- Klemp, J.B.; Wilhelmson, R.B.; Ray, P.S. 1981.** Observed and numerically simulated structure of a mature supercell thunderstorm. *Journal of the Atmospheric Sciences*. 38: 1558–1580.
- McCaul, E.W.; Weisman, M.L. 2001.** The sensitivity of simulated supercell structure and intensity to variations in the shapes of environmental buoyancy and shear profiles. *Monthly Weather Review*. 129: 664–687.
- Nelson, R.M., Jr. 1993.** Byram’s derivation of the energy criterion for forest and wildland fires. *International Journal of Wildland Fire*. 3: 131–138.
- Nelson, R.M., Jr. 2003.** Power of the fire—a thermodynamic analysis. *International Journal of Wildland Fire*. 12(1): 51–65.
- Palmer, T.Y. 1981.** Large fire winds, gases and smoke. *Atmospheric Environment*. 15(10/11): 2079–2090.
- Potter, B.E. 2002.** A dynamics-based view of fire-atmosphere interactions. *International Journal of Wildland Fire*. 11: 247–255.
- Reid D.G.; Vines, R.G. 1972.** A radar study of the smoke plume from a forest fire. Tech. Paper No. 2. Clayton South, VIC, Australia: Commonwealth Scientific Industrial Research Organization, Division of Applied Chemistry.
- Rothermel, R.C. 1991.** Predicting behavior and size of crown fires in the northern Rocky Mountains. Res. Pap. INT-438. Ogden, UT: U.S. Department of Agriculture, Forest Service, Intermountain Research Station. 46 p.
- Schroeder, M.J.; Buck, C.C. 1970.** Fire weather. Washington, DC: U.S. Department of Agriculture, Forest Service. 229 p.
- Simard, A.J.; Haines, D.A.; Blank, R.W.; Frost, J.S. 1983.** The Mack Lake Fire. Gen. Tech. Rep. NC-83. St. Paul, MN: U.S. Department of Agriculture, Forest Service, North Central Forest and Range Experiment Station. 36 p.
- Steiner, J.T. 1976.** Blowup fires—the Byram wind profile. *Australian Meteorological Magazine*. 24(3): 139–142.
- Taylor, R.J.; Bethwaite, F.D.; Packham, D.R.; Vines, R.G. 1968.** A meso-meteorological investigation of five forest fires. Tech. Paper No. 18. Melbourne, Australia: CSIRO Division of Meteorological Physics. 19 p.
- Taylor, R.J.; Corke, D.G.; King, N.K.; MacArthur, D.A.; Packham, D.R.; Vines, R.G. 1971.** Some meteorological aspects of three intense forest fires. Tech. Pap. No. 21. CSIRO, Australia: Division of Meteorological Physics.
- Taylor, R.J.; Evans, S.J.; King, N.K.; Stephens, E.T.; Packham, D.R.; Vines, R.G. 1973.** Convective activity above a large-scale bushfire. *Journal of Applied Meteorology*. 12(7): 1144–1150.
- Wade, D.D.; Ward, D.E. 1973.** An analysis of the Air Force Bomb Range Fire. Res. Pap. SE-105. Ashville, NC: U.S. Department of Agriculture, Forest Service, Southeast Forest Experiment Station. 38 p.
- Yang, M.-J.; Houze, R.A., Jr. 1995.** Multicell squall line structure as a manifestation of vertically trapped gravity waves. *Monthly Weather Review*. 123: 641–661.

Chapter 7: Spot Fires

Brian E. Potter¹

Introduction

Byram (1959) considered spotting “the worst behavior characteristic, both from the standpoint of fire suppression and the effect on fire intensity.” When a wildland fire produces embers that can be lofted and carried outside the main fire perimeter, the difficulty of managing the fire or containing it increases significantly. Ember showers can get into roofing shingles, gutters, and attics on houses and other buildings, igniting them in spite of any surrounding defensible space. Embers can start new fires across firebreaks, rivers, highways, and other unburnable areas and can produce a dangerous, distracting assault on ground crews. Even when the embers do not cross barriers, if they are numerous and dense enough, spot fires created by the embers can merge and create a separate, new fire front ahead of the previous fire front. Byram observed that “Although the spot fires occurring at long distances are spectacular and effective in spreading fire over large areas, the spot fires nearer the main flame front have a much greater effect on fire behavior. Showers of burning embers within a quarter or half mile of the main fire front occasionally produce disastrous firestorm effects by igniting large areas almost simultaneously.” Cheney and Bary (1969) stated that concentrated spotting near the fire front increases spread rate by a factor of three to five. Spot fires, for all of these reasons, are regularly considered a type of extreme fire behavior even though they are a normal characteristic of fires in some fuel types.

This section discusses scientific studies of the spotting process, the tools available to predict properties related to spotting, and the limitations of both the science and the tools. The primary areas for further research and tool development are also examined. While there are some tools for assessment of spot fire potential, they apply under specific circumstances. There is, however, much information that is not in a “tool” that will be valuable to a fire behavior practitioner.

Readers interested in more scientific detail should consult either the papers cited here, or one of three recent scientific papers: Koo et al. (2010), Gould et al. (2007), and Ellis (2000). Koo et al. (2010) is a scientific review of the literature on spot fires, emphasizing the physical equations and observations related to ember lofting, burning, and transport. Gould et al. (2007) is a detailed report from Australia’s Project Vesta, which studied high-intensity fires in dry eucalypt forests. The report discusses far more than just spotting, and the observations in the study are largely specific to eucalypt forests and spotting, but this is the most readily available report of field observations on spotting to be found. The discussion and some of the observations are widely applicable. Ellis (2000) examined the aerodynamic and burning properties of several species of eucalypt bark and contains a substantial discussion of episodic long-distance spotting. All three papers also contain many relevant references.

The Spotting Process

In its simplest form, spotting is the creation and transport of embers or fire brands followed by ignition of fuels where those embers land. Considering the details of that simple description reveals the complexity behind the process. Most scientific research frames spotting as a three-stage process: ember production, lofting and transport, and ignition. In practice, the discussion of the middle stage—lofting and transport—is commonly split into two smaller stages. Lofting is the vertical portion and depends more on the fire’s plume, while transport is primarily the horizontal portion and depends more on the environmental winds. The ignition stage includes the stage of the ember’s life spent on the ground after transport, part of which is spent burning before it ignites any other fuels. These stages are each relatively tractable in terms of the scientific questions they pose. Implicit in the stages, though, is the fact that the ember is burning and losing mass, which changes how the winds drive it and how fast it falls.

¹ **Brian E. Potter** is a research meteorologist, U.S. Department of Agriculture, Forest Service, Pacific Wildland Fire Sciences Laboratory, 400 N 34th St., Suite 201, Seattle, WA 98103.

An individual ember starts as a leaf, twig, seed, nut, pine cone, piece of bark, or small fragment of a larger piece of fuel that was partially consumed. It may originate on the ground, in the understory, or in the canopy. The air currents associated with the fire must lift the ember up into the fire's plume, until the air currents or gravity take it out of the updraft. As the ember falls to earth, the winds continue to push it horizontally—and perhaps vertically, if it gets caught in an eddy. All through this journey, the ember continues to burn, losing mass (if it stops burning for some reason, it is no longer a spotting hazard). As the ember's mass decreases, the wind pushes or carries it more easily, and it settles toward the ground more slowly. Eventually, however, the ember reaches the ground or perhaps it comes to rest in a tree canopy or understory vegetation. If it lands in flammable fuel, it may ignite that fuel if the ember has enough energy to dry and heat the fuel to the combustion point. That drying and heating may take some time, resulting in an ignition delay. At this point, the ember has established a spot fire.

Some embers, especially large ones, land relatively close to the main fire front. The closer they land to the front, and the longer they take to ignite the recipient fuels, the more likely it is that the main fire front will overrun

them and the less likely that they will cause the fire front to hop forward. The zone where overrunning occurs has no definite size—it depends on the fire's rate of spread, the fuel moisture, and, again, the fuel type (fig. 7-1). Even in these cases, however, heavy showers of embers can gradually dry and heat the fuels so that the fire spreads more rapidly when the main front arrives.

Cheney and Bary (1969) described two distinct patterns of spotting in eucalypt fires, and similar patterns have been reported for other vegetation types (e.g., Countryman 1974, Wade and Ward 1973). The first pattern includes a profusion of embers a short distance from the fire, with numbers decreasing as distance from the fire front increases. The second pattern includes embers landing in groups at varying distance from the fire front, with few embers observed between the groups. This second pattern is associated more with long-distance spotting.

Muraszew and Fedele (1976) referred to the “zone of fire front over-take” and the “zone of spot fire hazard,” the former identical to the overrun zone in figure 7-1. In discussing the spotting process, they echo Byram's (1959) comments about the profusion of spot fires that can occur within a quarter to a half mile of the fire, or just beyond the

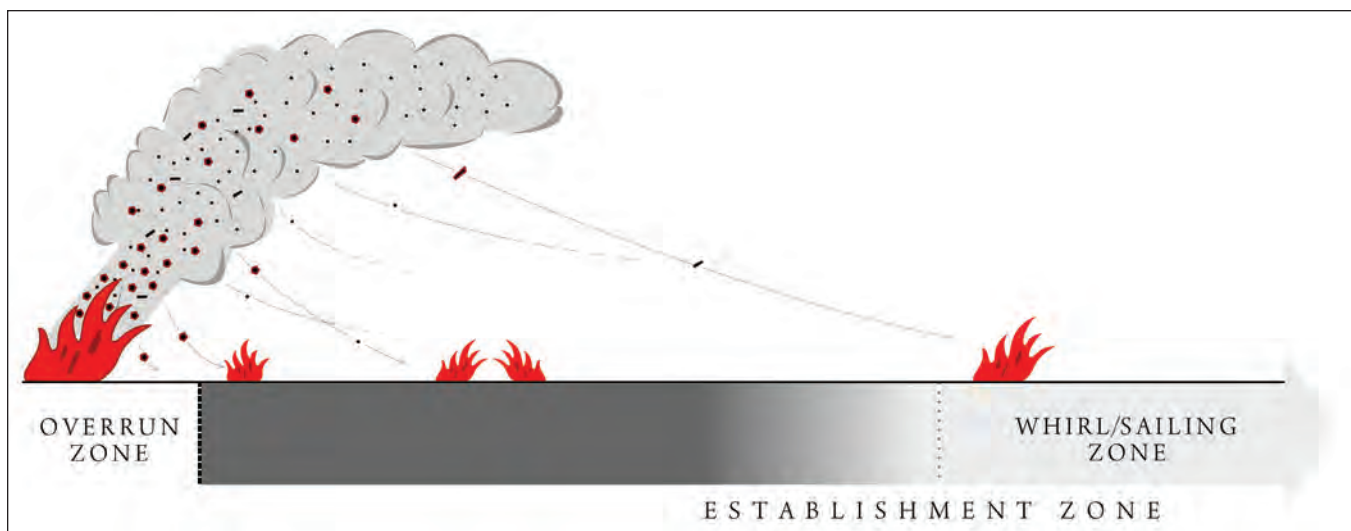

Figure 7-1—Conceptual diagram (not to scale) of the spotting process, illustrating the influence of ember size and shape, lofting height, and ignition. Thin arrows are ember trajectories, those ending in dashed lines indicate the ember burned completely and never reached the ground. Round embers represent woody embers, and the stick-shaped ember leaving the top of the plume represents aerodynamic embers (typically bark) or large embers lofted extremely high by fire whirls or intense surges in the fire.

overrun zone. In this area relatively close to the fire, spot fires can establish and merge, leading to sudden surges in fire progress or intensity similar to what McArthur (1967) described as a typical spotting behavior in eucalypt fires, Wade and Ward (1973) documented for the Air Force Bomb Range Fire in North Carolina, and Gellie et al. (2010) described for the 2009 Black Saturday fires in Australia.

Ember Generation

Most studies of embers and spot fires simply state that there is not enough information on the number or size of embers generated by burning vegetation. The term “ember generation” is common usage but is not particularly accurate. Embers that burn out in the air are clearly not relevant to actual spotting, and no study has documented the number or size distribution of these embers quantitatively. While the number of embers landing on the ground is not the same as the number produced, it is much more easily measured, and arguably the quantity of greater interest.

Modeling studies by Muraszew and Fedele (1976), Koo et al. (2007), Sardoy et al. (2008), and Perryman (2009) each assumed a number, size, and time distribution of embers. Muraszew and Fedele (1976) started from nine fuel models included in the 1974 (revised) version of the National Fire Danger Rating System (A through I) and divided the dead fuels with moisture content below 20 percent into size classes. Assuming cylindrical fire brands with a length-to-diameter ratio of 10, they produced an equation that converted the dead fuel mass to a number of fire brands produced every second along unit length of fire front. They stated that this approach cannot be applied without field observations of spot fires and spot fire coalescence to guide the value of some of the parameters they require. To date, there are no published field observations to serve this purpose.

Koo et al. (2007) assumed that at any location that was burning in their model domain, one ember would be produced each second for every 2- by 2-m area. The size of that ember was the largest that could be lifted by the model updraft at that location and time. These embers ranged in size up to 8 mm thick and 36 mm radius (disks), or 3.5 mm

radius and 21 mm long (cylinders). Sardoy et al. (2008) took a similar approach, releasing 10,000 disk-shaped fire brands of random size (1 to 3 mm thick and 4 to 10 cm in diameter) and density (50 to 300 kg/m³) into a modeled plume. Perryman (2009) used what was essentially a tree-level model of fire spread, in which any torching tree produced 50 embers. Rather than computing the size of each ember, Perryman specified landing distances using a probability model.

In their discussion of the European SALTUS project, Colin et al. (2002) briefly mentioned some of the characteristics of embers observed during observations on 48 wildfires that occurred in France, Greece, Italy, Portugal, and Spain between 1998 and 2001. They reported that one third of the embers collected (a total of 30) on these fires were leaves or needles, and the next most abundant embers were from pine bark fragments or twigs (The only indication of the vegetation species given in this paper is reference to *Pinus pinaster*). Leaves and bark fragments traveled the farthest, and a third of the particles were larger than 5 cm. The very low number of embers collected, 30, out of 48 wildfires, reflects the difficulty of studying ember production on wildland fires.

Two recent studies examined the number of embers produced during experimental wildland fires. Racher (2003) studied embers produced in saltcedar (*Tamarix* spp.) and juniper/oak (*Juniperus* spp./*Quercus* spp.) stands in Texas by laying out plastic sheets downwind of the fires, where landing embers burned holes in them. The field crew also recorded distance for spot fires observed outside the study area. The author did not report the number of embers generated, but did document that saltcedar yielded significantly more embers that reached the ground than did juniper/oak. One point Racher specifically noted was that among the saltcedar fires, those producing the most numerous or distant landing embers were not those with the greatest rate of spread, flame height, or flame depth zone—fireline behavior was a poor predictor of spotting number or distance. Too few embers were captured in the juniper/oak experiments to make a similar statement.

Gould et al. (2007) applied similar techniques during Project Vesta. Plastic sheets were laid out on the forest floor

downwind of the burn plots, and the number of holes burned during the fires was recorded in terms of holes per unit area and location. The results are presented as spatial contour plots (number per unit area), and focus largely on the spatial distribution of the landing embers. This will be discussed shortly, but there are three points of note for the present discussion. First, the authors found that the number of embers was proportional to the time since the (eucalypt) stand had last burned. Second, the authors document cases where large embers broke into multiple small embers on landing, scattering apart and burning distinct holes in the plastic sheeting. Third, when the fires reached the established fire-breaks on the downwind sides of the burn plots, the loss of fuel and energy caused a visible decrease in plume energy, and an accompanying shower of many embers near the fuel boundary. While the first of these points may be primarily relevant to eucalypt forests, the second could apply to other types of vegetation, and the third is likely to be universal. Any fire with embers in the updraft, should it encounter an abrupt decrease in available fuels, will likely exhibit similar behavior.

Two laboratory studies examined the number and size distribution of embers produced by vegetation. Manzello et al. (2007a) burned individual 2.6- and 5.2-m tall Douglas-fir (*Pseudotsuga menzeisii*) in a windless laboratory and collected the embers in pans of water. Manzello et al. (2007b) repeated this exercise with Korean pine (*Pinus koraiensis*). These papers clearly illustrated that the ember size distribution depends on the tree size and species (fig. 7-2). All of the embers collected were cylindrical twigs, and the authors concluded that all needles were completely consumed (this differs from the SALTUS findings). Albini (1979) noted that embers may begin as twigs with leaves attached and end their life as a twig without leaves. Some of the needles may possibly have been consumed in flight, but this was not examined by Manzello et al. (2007a, 2007b).

The studies provide several observations of immediate value to fire management. For example, in the absence of wind, Douglas-fir with moisture content over 30 percent did not produce embers. The largest Douglas-fir embers came from the 5.2-m trees; maximum mass observed was

3.7 to 3.9 g, maximum length was 200 mm, and maximum diameter was 10 mm. The 2.6-m Douglas-fir trees produced embers of similar diameters but lengths below 150 mm and maximum mass between 2.1 and 2.3 g. The average ember twig for all of the Douglas-fir trees was 3 mm in diameter and 40 mm long.

While these maximum dimensions are important, they do not reveal the full picture. Figure 7-2c reproduces the mass distribution Manzello et al. (2007a) found for embers from the 5.2-m Douglas-fir tests. This shows that 70 percent of the embers recovered were smaller than 0.3 g, with 10 percent between 0.3 and 0.5 g. Larger size classes contained progressively smaller fractions of the total ember mass.

The Manzello et al. studies discussed some of the substantial difficulties involved in collecting data on embers. Laboratory facilities effectively limited the experiments to single trees, less than 5.2 m tall, in a windless environment. Furthermore, because the authors could not capture every ember produced, or every one that fell to the ground, their results are limited to expressing the mass distributions as percentages of the total collected. There is no information on the total number produced or landing on the ground.

Ember Combustion and Fall Speed

Where an ember ultimately lands depends on its fall speed relative to the air around it. That fall speed depends on the size, shape, and mass of the ember and so on how the ember burns.

Tarifa et al. (1965, 1967) performed the first, and most extensive, tests of ember fall speed. They examined embers of various shapes, sizes, and wood species as well as charcoal embers and pine cones (table 7-1). Their wind tunnel measurements indicated that the embers lost mass quickly once they ignited, while size decreased slowly at first and then with increasing speed. Combined, these factors led to a rapid decrease in fall speed, followed by a period where the fall speed decreased more gradually. Figure 7-3 shows an example of the change in fall speed as the ember burns. Because denser wood also burned slower, they found that embers from denser tree species traveled both higher and

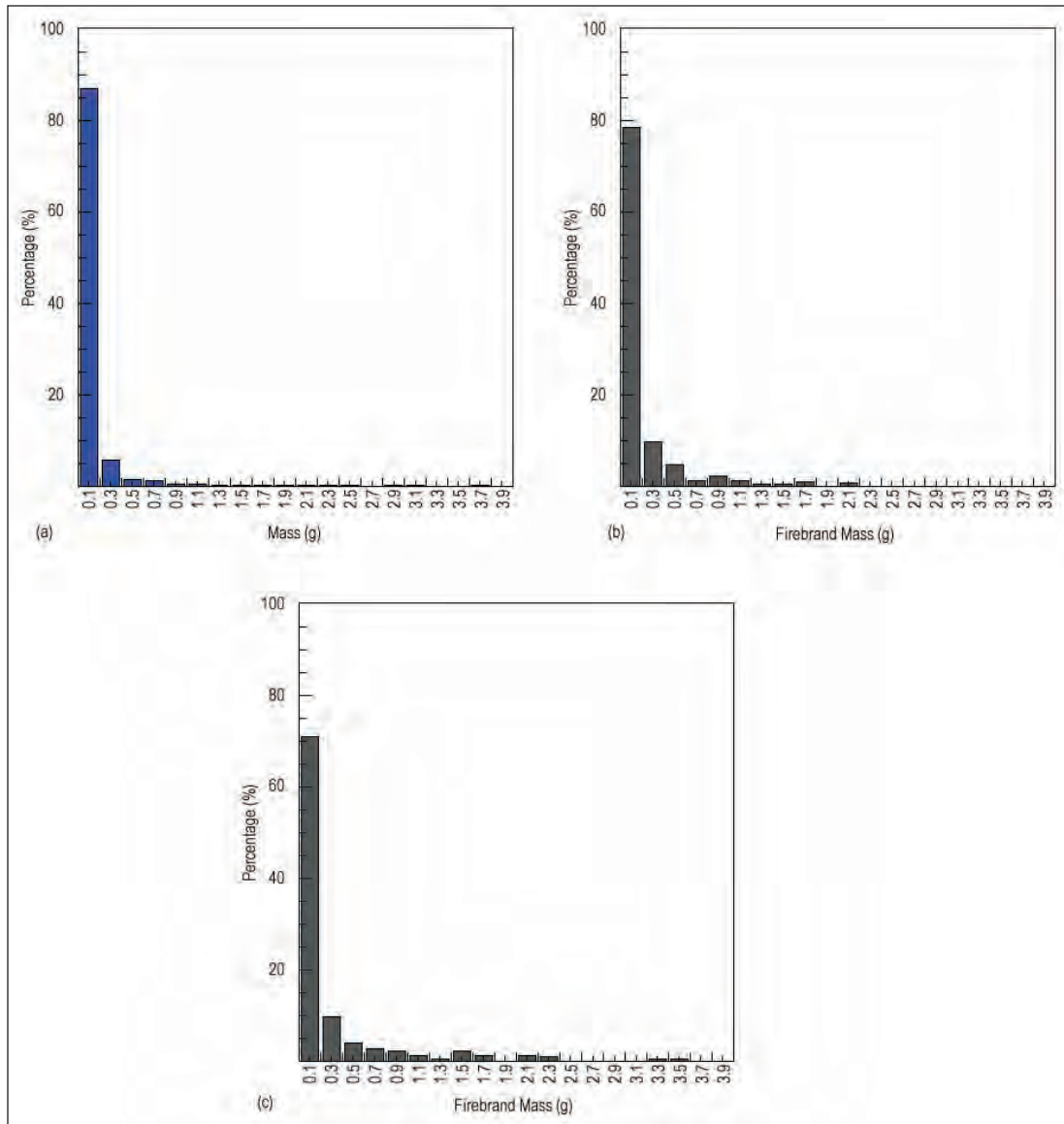

Figure 7-2—Mass distribution of collected firebrands for (a) 4.0-m Korean pine trees, (b) 2.6-m Douglas-fir trees, and (c) 5.2-m Douglas-fir trees. From Manzello et al. 2007b.

Table 7-1—Sizes, shapes, and species of embers studied by Tarifa et al. (1967)

Shapes	Sizes	Species
Cylinder	(Diameter x length)	Aspen (<i>Populus tremuloides</i>)
	6 × 18 mm	Balsa (<i>Ochroma lagopus</i>)
	8 × 24 mm	Oak (<i>Quercus rubra</i>)
	10 × 30 mm	Pine (<i>Pinus pinaster</i>)
	12 × 36 mm	Spruce (<i>Picea excelsa</i>)
	15 × 45 mm	(Charcoal)
		(Pine cones)
Square plate	(Thickness x face length)	
	2 × 32 mm	
	4 × 32 mm	
	8 × 32 mm	
	16 × 32 mm	
	2.5 × 50 mm	
	5 × 50 mm	
	10 × 50 mm	
25 × 50 mm		
Sphere	Diameter: 10, 15, 22 mm	

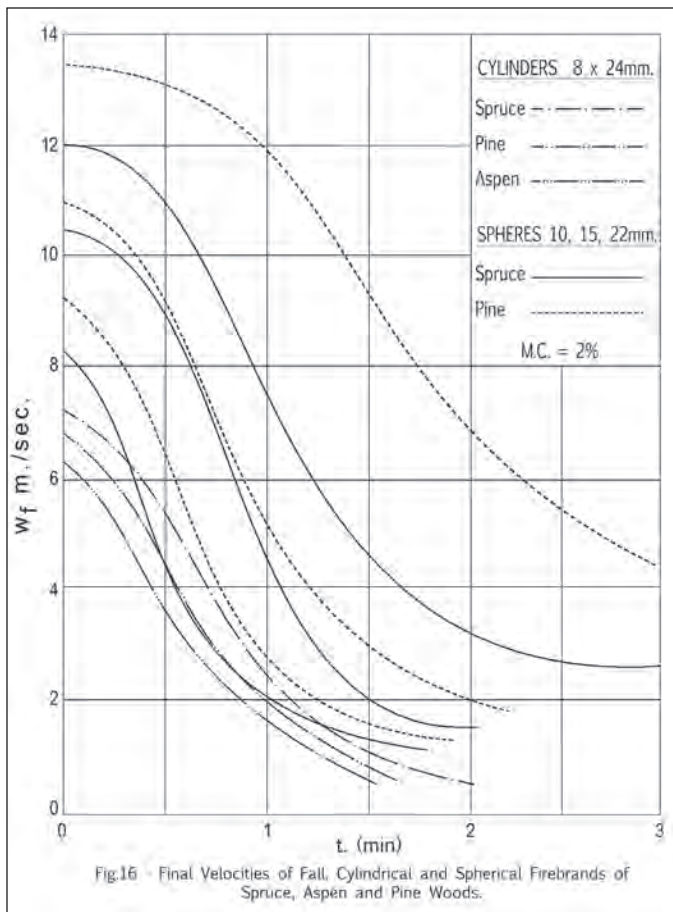

Figure 7-3—Final velocities of fall. Cylindrical and spherical firebrands of spruce, aspen, and pine wood from Tarifa et al. (1967).

farther, even though the denser embers' fall speeds were higher for a given size and shape. They concluded that charcoal embers, because of their slow burning rate, are among the most dangerous—they can travel much farther before they burn out completely.

In their model simulations of ember transport and combustion, Tse and Fernandez-Pello (1998) modeled ember combustion as two separate elements. Pyrolysis is the thermal decomposition expulsion of volatile gasses in the woody fuel; it reduces the mass but has very little effect on size. Combustion of the remaining carbon then leads to the ember shrinking. To determine the rates of these processes, they determined reaction coefficients from Tarifa et al.'s (1967) data, and the net result was similar mass and size changes. This two-process combustion model has since been used for numerous studies (e.g., Anthenien et al. 2006; Bhutia et al. 2010; Sardoy et al. 2007, 2008).

Ellis (2000) is the only study to examine the combustion and fall speed properties of eucalypt bark. Eucalypt bark fragments are considerably more difficult to characterize than cylinders, plates, or spheres, as they can be small plates with comparable length and width, long narrow strips, or curled tubes. The edges are often irregular. These shape variations produce two general categories of falling behavior, either “spin free” or fast-spinning. Furthermore, spinning behavior has two aspects, one where a long strip or tube rotates around its long axis, the other where the whole strip rotates around an axis perpendicular to its long axis. Ellis found that the spinning bark fell more slowly (ranging from 2.5 m/s to 6 m/s) than nonspinning bark (ranging from 3 m/s to 8 m/s) when other properties were similar. Spinning or nonspinning, most bark samples had fall speeds between 2.5 m/s and 4 m/s, approximately one-half the initial fall speeds for the shapes tested by Tarifa et al. (1967).

The differences between solid wooden embers and bark embers, in terms of shape, density, falling behavior, and burning pattern identified by Ellis result in distinctly different spotting impacts. Any model derived for spotting distance or ember trajectories that depends on solid wooden ember behavior is inappropriate for application to eucalypt bark embers. The rates at which bark loses mass and at which its fall speed decrease are much slower than for solid

wooden embers, resulting in greater spotting distances, on the order of twice as far.

Ellis (2000) also observed one characteristic of ember combustion not examined by others. Tarifa et al. (1965, 1967), Muraszew (1974), and Muraszew et al. (1975, 1976) all mentioned that ignition time was important for them in getting consistent results for firebrand combustion, mass loss, and fall speed. These authors chose ignition times sufficiently long to ensure continued combustion throughout their experiments. Ellis looked at how ignition time influenced bark combustion, and by doing so identified two distinct types of burning behavior. Embers characterized by high combustion rates and maximum flaming duration were classified as “normal.” Other embers, generally subjected to ignition more briefly, burned slowly, remained flaming more briefly, and had a high tendency to reflare after a period of glowing combustion. Ellis classified these as “extreme,” and noted they were most likely to cause long-distance spotting. Ignition time was one factor distinguishing normal from extreme embers, but bark sample size and structure appeared to be important factors, as well.

Lofting and Transport of Embers

Fuels on the ground are relatively unlikely to get lofted by the fire's plume—it is difficult for air currents to lift them. Because the fire's updraft initially accelerates as it rises, it is more likely for embers to originate higher up in the fuel structure, and therefore for spotting to be more prolific in crown fires than in surface fires. Twigs, seeds, and bark in the canopy are the most likely source of embers in the updraft, and those likely to reach the establishment zone.

None of the ember lofting studies have measured ember lofting in an actual wildland fire. All of the studies described here used some manner of model wind field to calculate ember lofting. The differences among the various models arise largely from the assumptions made by each set of authors, and there are no data available to compare them.

The winds, and specifically the updraft, near the flaming front are highly turbulent and difficult to measure. Acknowledging that “theoretical models calculated for thermal plumes do not apply” to convection columns over large wildland fires, Tarifa et al. (1965, 1967) nonetheless

relied on previous theoretical and laboratory studies of convection to model the updraft for lofting of embers. They tested two convection models; one was a purely vertical updraft with constant speed, the other a tilted convection column with constant speed in both the vertical and horizontal directions. Once the embers were lofted by either model, horizontal transport was based on a horizontal wind field constant in both space and time.

Gould et al. (2007) reported observations that illustrate the difficulties involved in modeling the wind field lofting embers. They saw the fire behavior alternate between updraft periods and downdraft periods. Strong updrafts pulled the flames inward to the base of the updraft and exhibited decreased rate of spread. Updrafts were also held responsible for producing spot fires tens to hundreds of meters from the fire front. Downdraft periods, the authors state, produced rapid fire progress as a downward rear inflow at the fire front drove the fire. Embers produced in these periods appeared in showers at distances of a few meters to a few tens of meters. The duration of these periods was on the order of 1 to 3 minutes, and not all parts of the flaming front exhibited the same behavior at any given time. Clearly, this behavior challenges any steady-state model.

Muraszew (1974) made assumptions similar to those in Tarifa et al. (1965, 1967) about the convective lofting of embers. He cited many of the theoretical models Tarifa et al. noted did not apply to wildland fire columns. Nonetheless, with no other data on convection over a wildland fire, there was little alternative. Muraszew (1974) therefore assumed a constant vertical velocity in the plume, although he hypothesized increasing velocity in the lowest 50 m or so, referring to this as the “high buoyancy zone.” One implicit assumption in the paper is that the atmosphere is neutrally stable. Because there is more potential for air rising in an unstable atmosphere to accelerate, the calculations may underestimate the lofting potential of the fire’s updraft. How much it may be underestimated is not clear and would vary widely based on case-by-case specifics.

Using these simplified convective models, Tarifa et al. (1965, 1967) and Muraszew (1974) reach similar conclusions. First, as shown in figure 7-4, for a fire updraft on the

order of 30 m/s with 20 m/s horizontal winds, the modeled embers (cylinders 24 mm long and 8 mm in diameter) reached the ground 1300 m from the updraft (for the purely vertical convective column) or 5600 m from the fire front (for the tilted column). In the case of the tilted column, however, the embers had to originate 560 m behind the fire front and the 30 m/s updraft had to be present throughout this 560-m region—a physically unrealistic assumption. This does not account for the distance the fire would move while the ember was airborne, which could be substantial with a 20-m/s wind.

Aside from Muraszew’s inclusion of an accelerating updraft near the surface, these model winds were constant in both space and time. Increasing the realism of the plume model by adding spatial variability, Anthenien et al. (2006) and Sardoy et al. (2008) modeled ember transport using plume models that allow the winds to vary in space. The details of the plume models differ, but both basically represent a stationary fire of fixed size with a rising plume that leans over with the crosswind and widens downstream from the heat source, with the speed of the updraft determined by the fire’s energy output rate. In Anthenien et al., the updraft ranged from about 10 m/s for a 10-MW fire to roughly 14 m/s for a 40-MW fire. The embers and spotting produced by this model were very short range, with 2-mm embers in a 40-MW fire landing just 70 m downwind. Larger embers landed closer, while smaller embers burned up completely without reaching the ground. Considering the updrafts are much weaker and the embers are of comparable size, these results are not inconsistent with the results of Tarifa et al. (1965, 1967) and Muraszew (1974).

Sardoy et al. (2008) assumed that the plume updraft was 12 m/s at canopy top for fire energies between 10 and 40 MW. Their study focus was not on ember size relationships to transport distance so the results do not directly compare with the previously mentioned studies. Generally, they found transport distance fell into short- and long-range categories, with high-density or large embers in the short-range and less dense or smaller embers in the long-range

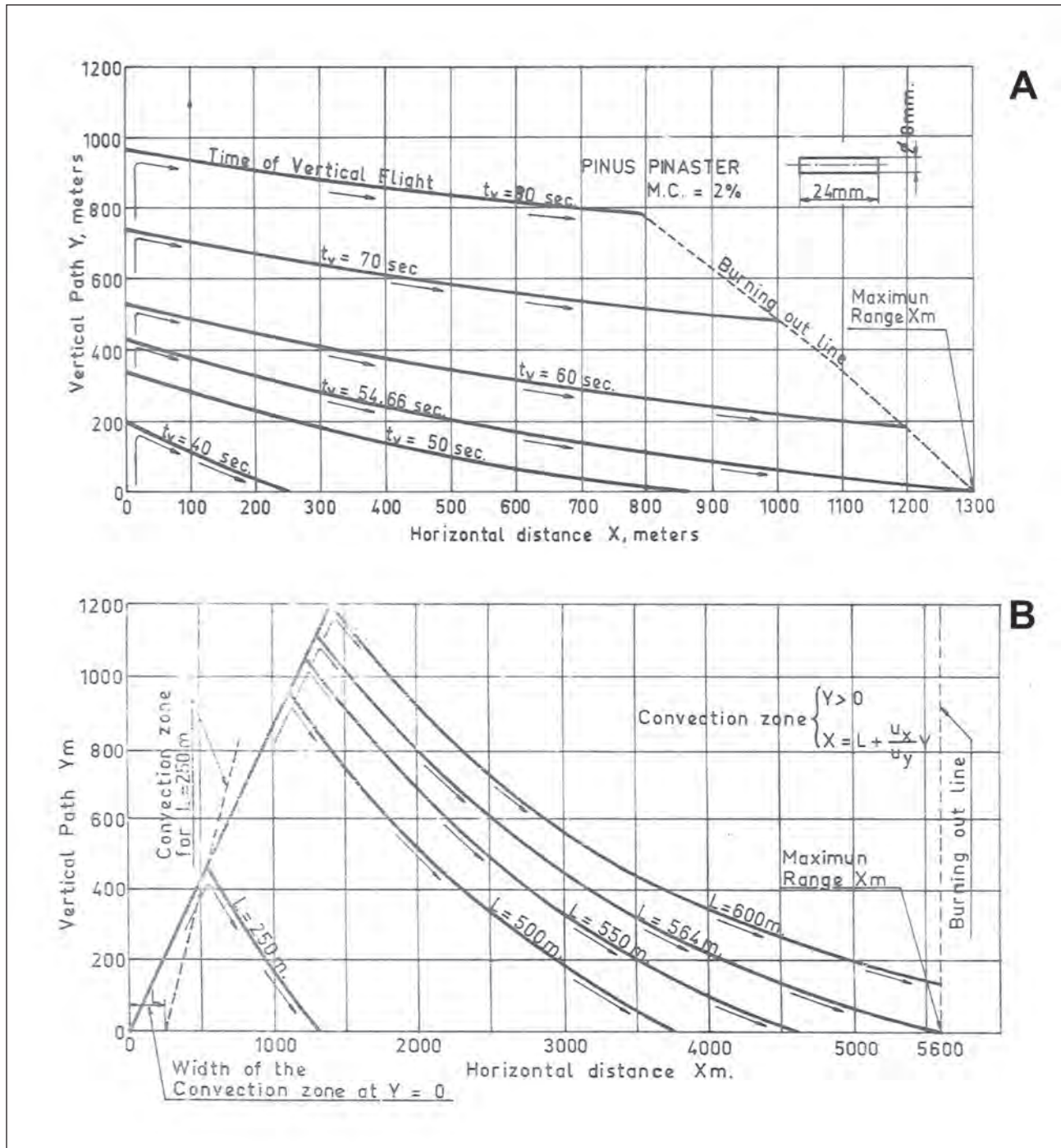

Figure 7-4—Flight paths of (a) cylindrical firebrands in a vertical convection column and (b) spherical firebrands in an inclined convection column. From Tarifa et al. 1967.

group. Short-range spotting covered distances out to about 400 m, while long-range spotting was concentrated between 5000 and 9000 m. The embers in the short-range group were more numerous and landed in a flaming state, while the long-range embers, fewer in number, were not flaming. Furthermore, for a given fire intensity and horizontal windspeed, the distance groupings had a distinct separation between them that depended on the char content of the ember—higher char content decreased the separation distance. The general results of this study are not usable in the field, unfortunately, as they do not provide enough information on how the fire intensity, windspeed, and char content interact in determining spotting distance or long- vs. short-range separation.

Albini (1983a) took a slightly different approach to modeling ember lofting. He assumed that embers are lofted by a line thermal, not in a steady-state wind field. Albini's line thermal is a two-dimensional bubble of hot air, elliptical in shape (shorter in the vertical than in the along-wind direction) produced by a line of fire infinitely long in the across-wind horizontal direction. Starting with a thermal bubble at the ground and an ember at the top of that bubble, Albini derived a simple equation for the maximum height an ember could rise and still fall back to the ground to light a fire. After the assumptions Albini built into the model, this relationship depended only on the ambient atmospheric pressure and the energy (per-unit length in the across-wind direction) of the thermal bubble. He provides one example, wherein the heat released by burning 5 kg/m of fuel provides 10^8 J/m of energy and lofts the ember to 55 m above ground. Lofting the ember to 550 m would require 100 times this energy, 10^{10} J/m, and 500 kg/m of fuel. Perhaps the greatest difficulty in using Albini's equations lies in the question of how much fuel one assumes heats one individual thermal bubble—there is no guidance to suggest how long a thermal bubble remains near the ground to absorb energy from fuel burning at a certain rate.

All of these studies assume idealized, two-dimensional, near steady-state conditions for the lofting winds. In the last 5 years, there have been two papers that used coupled fire-atmosphere models to look at the influence of the short

term, three-dimensional fluctuating winds at the fire front on lofting of embers. These models allow the combustion process to influence the winds, which in turn can influence the combustion process. This means, for example, that if the fire causes wind to accelerate, that accelerated wind will affect the rate of spread.

Koo et al. (2007) used the Los Alamos FIRETEC model (Linn et al. 2002) to examine spotting. Their ember production was purely idealized (it did not depend on the burning fuels but rather on fuel temperature and the largest disk or cylindrical ember that model surface winds could loft) and they did not examine ignition directly. The question of lofting was not the focus of their work, and computational limits required them to model an area only 320-m square, but the results do show clearly the potential to use coupled models for spotting studies. Their simulations for full or patchy forest fires with a 6 m/s ambient wind yielded maximum ember landing distances near 190 m, with the average distance closer to 30 m.

Bhutia et al. (2010) used the University of Utah's Large Eddy Simulator (UU-LES, Sun et al. 2009) to perform similar simulations. The authors set out to examine the difference between a steady-state plume and a coupled fire-atmosphere model in terms of ember transport. The steady-state plume automatically produces the same ember lofting and transport for a specified size of ember. Combusting spheres 20 mm in diameter, for example, only rose to about 20 m before they burned out. Embers released at 50 m above ground traveled slightly less than 50 m before landing. When embers were released from 50 m above ground in the coupled model, however, they landed between roughly 40 and 70 m downwind.

The authors state that the work is exploratory and recommend further exploration. This is reinforced by the fact that their model carries nonburning spheres much farther than initially identical burning spheres for both the steady-state and LES tests. Specifically, 10-mm diameter nonburning spheres released at 50 m in the steady-state case landed just short of 100 m downwind of the release point while burning spheres landed approximately 70 m downwind. The authors claim

that this is due to the burning particles heating the air around them, thereby reducing its density and the drag exerted on the particle. In their model, this effect exceeds the effect of decreasing mass for the combusting particles so much that the net effect is that burning sphere trajectories are 30 percent shorter than nonburning spheres. No other study in spotting literature has compared burning and nonburning projectiles, so there is no other literature for direct comparison. However, the magnitude of the effect here is substantial, and until observations confirm this effect, one should exercise caution in applying any results from Bhutia et al. (2010).

Because there are documented spot fires at greater distances than 5 km, there must be some process besides “smooth” or steady-state convection involved. Candidates include more aerodynamic embers such as the eucalypt bark discussed in Ellis (2000), slower burning embers such as char discussed by Tariffa et al. (1967), or stronger lofting. Lee and Hellman (1969) proposed that the most likely candidate was fire whirls, citing Countryman (1964) in doing so. Countryman (1964) stated “...fire whirls and tornadoes contribute greatly to fire spread because they pick up large firebrands and scatter them over a wide area. Many wild-fires seemingly controlled have been lost when a fire whirl scattered burning debris across the cleared fire lines.” Note that Countryman does not state that whirls throw firebrands farther than nonwhirl convection does, rather he states that whirls scatter embers over a wide area. A further curiosity arises in Byram’s (1959) discussion of spotting and fire whirls. In the original version of this text, “fire whirlwinds” appear as part of a section on spotting. In the revised version of the text, Brown and Davis (1973), fire whirlwinds are a separate section with essentially unchanged text—the formatting strongly suggests that the appearance as a subsection was a type setting error. It is possible that historically, the perception that fire whirls produce longer distance spotting is in part due to misinterpretation and a printing error.

These historical points notwithstanding, it is physically plausible that fire whirls could loft large embers high and produce long-distance spotting. Lee and Hellman (1969, 1970) presented theoretical analyses of whirl lofting and

transport. While these represented significant scientific progress, they could not be translated to the field. The models included too many variables that are unknown, perhaps unknowable, in the field before a whirl forms. The mathematical solution required replacing distances, speeds, and other quantities with unitless quantities, and without knowing such things such as the radius of the fire whirl, the upward speed of the air in the core of the whirl, and the rotational speed of the whirl at the bottom, one could not convert the unitless quantities to real, physical dimensions.

Muraszew et al. (1976) and Muraszew and Fedele (1976) simplified the work of Tariffa et al. (1967) and of Lee and Hellman (1969, 1970) to make it applicable in the field but did so with limited success. Specifically, Muraszew and Fedele (1976) stated they had to assume that “subsequent studies will provide for statistical determination of the strength and vertical extent of the ambient circulation and its probability of generating a fire whirl in terms of terrain, fuel and wind conditions.” No such information is available for wildland fire at this time, and so the computer model Muraszew and Fedele produced cannot yet be directly applied in the field. The tables Muraszew et al. (1976) produced using reasonable values for these unknowns, however, do provide useful information. At the least, they show that the updraft in a fire whirl can easily be 30 m/s, comparable to the nonwhirl updraft in Tariffa et al. (1967), and is more likely to be 100 m/s. Their highest value—corresponding to the highest circulation, shortest whirl with the heaviest fuel loading—was approximately 170 m/s. Such an updraft, or even the 100 m/s updraft, could easily lift embers larger than any studied by Tariffa et al. (1967). Muraszew et al. (1976) illustrated this with an example involving a ponderosa pine bark plate 6.3 mm thick and 100 mm square. They modeled a whirl lifting the plate to a height of 1200 m and found that landed approximately 3300 m with a travel time of just over 6 minutes, still burning.

Berlad and Lee (1968) presented perhaps an alternative vortex model for long-range ember transport and spotting. The authors consider the possibility that vortices form at the fire, where they collect embers in their columns, and

that the vortices hold those embers aloft as they separate from the fire and travel downwind (see the discussion of vortex shedding in the chapter on vortices). As the vortices weaken over time, they lose their ability to support the embers and eventually the embers fall out. That weakening can be the result of several factors, such as friction near the ground, slow mixing with air from outside the vortex, or moving upslope, which shortens the vortex and slows its spin.

Ignition

Spot fire ignition has three critical aspects. First is where the embers land, which depends on the transport issues already discussed. The probability of ignition, taken with the expected number of embers landing in recipient fuels, determines the overall likelihood of a spot fire developing. When an ember does cause ignition, it is not instantaneous and there is an ignition delay time. Both the probability of ignition and ignition delay time depend on many of the factors important to spotting, in general: ember size and mass, windspeed, and combustion state (flaming versus glowing). In addition, the type and state of the recipient fuels are important, as are the number and distance between multiple embers.

Probability of Ignition

Ignition probability depends in part on the ease of igniting the receptor fuels, their ignitability. There are many studies of ignitability, and White and Zipperer (2010) discussed these and the methods used in detail. However, the majority of such studies use radiative heating or ovens to test ignitability, rather than embers. The nature of the heat source used to evaluate ignitability exerts a strong influence on the results of any tests and should always be considered before using the results of any particular study or report in the context of spotting.

In unpublished work in 1969, Schroeder² laid out a methodical description and analysis of how to determine probability of ignition from embers. His work is the precursor to the tables in the Fireline Handbook and the BEHAVE

tools. It considers the heat needed to ignite fuels based on their moisture content, the size distribution of fire brands and the heat they can provide, and the efficiency of heat transfer from the brands to the receptor fuels. The resulting tables are the probability of one or more ignitions by the total population of embers, not the probability that a single ember will result in an ignition. The latter probability is necessarily less than or equal to the former. (Note that Schroeder extensively cites an unpublished 1969 manuscript by Blackmarr, but the citation is incomplete. It appears to be the same as, or very similar to, Blackmarr 1972).

While earlier spotting studies noted the importance of ignition probability, none specifically addressed that probability. Similarly, earlier studies (such as Blackmarr 1972) had addressed the general question of fuel ignitability, but Bunting and Wright (1974) was the first to specifically examine ignition probability for spot fires. They studied ignition of partially decomposed (punky) wood and dried cow chips in Texas grasslands using nonflaming juniper embers. They found that ignition probability for either fuel increased most strongly with decreasing 10-h fuel moisture. The second most influential factor for cow chips was maximum windspeed, while for punky wood it was the time since last precipitation event.

The next experimental study of ignition probability appears to be Ellis (2000). This work involved laboratory observations of ignition when glowing or flaming fragments of stringybark landed on Monterey pine litter. With fine fuel moistures below 9 percent, flaming embers with mass between 0.7 and 1.8 g had a 100 percent probability of igniting the litter. Glowing embers had lower probabilities. Without any wind, the glowing embers (mass between 0.1 and 0.4 g) did not produce ignition. With a light wind (1 m/s), the probability increased in a roughly linear manner from about 20 percent at fine fuel moisture of 9 percent to approximately 65 percent at a fine fuel moisture of 3.5 percent. Ellis did not test higher fuel moistures.

Manzello et al. (2006) studied ember ignition of pine needles, shredded paper (similar to house insulation), and cedar shingles in the laboratory. They did not express their results as a numerical probability, but noted whether embers

² **Schroeder, M.J. 1969.** Ignition probability. Unpublished report. On file at: U.S. Department of Agriculture, Forest Service, Rocky Mountain Forest and Range Experiment Station, Fort Collins, CO.

produced smoldering or flaming ignition. They found that flaming embers as small as 0.5 g could ignite pine needles with fuel moisture of 11 percent or less. Glowing embers did not ignite needles, even when four embers of 1.5 g each were placed within proximity (just how close was not specified, but the implication is a few centimeters.)

The most extensive study of ignition by embers is documented in Guijarro et al. (2002) and Ganteaume et al. (2009). These papers describe the results of dropping numerous types of vegetative embers into a variety of fuel bed types with a range of windspeeds (table 7-2). In one portion of their work, they used 2-g blocks of Scots pine as flaming embers to ignite the various fuel beds without wind. Their results produced an expression for ignition probability as a function of fuel bed bulk density (kg/m^3) and fuel moisture (percentage), as shown in table 7-3. Higher bulk density or lower fuel moisture led to higher probability of ignition. Application of the equation or table 7-3 requires recognition that it came from measurements on specific Mediterranean fuel types, with bulk densities between 9 and 70 kg/m^3 and fuel moisture between 1 and 11 percent.

When these authors looked at the various combinations of embers, fuel beds, flaming/glowing embers, and wind, they computed nine probability equations because the results varied widely. In summary, they found that some embers (Aleppo pine scales) had very high ignition success rates when flaming, but very low when glowing. Others (Aleppo pine bark) had low ignition rates when flaming but were among the highest when glowing and subject to wind. Similarly, among the fuel beds cured, grass ignited most often with flaming embers, but Stone pine litter ignited most readily when the ember was glowing and there was light wind.

Ignition Delay Time

Muraszew (1974) included discussion and analysis of ignition delay time based on laboratory measurements of ember burning time and a theoretical model analysis of how the burning ember interacts with unburning fuels around it. He studied both flaming and glowing embers, but the model analysis applied only to flaming embers and assumed that these embers would ignite fuels that were within the flame. He noted (but did not model or measure) that glowing

Table 7-2—Ember types, fuel bed types, and windspeeds studied by Ganteaume et al. (2009)

Ember types	Fuel bed types	Windspeeds
Aleppo pine twig	Aleppo pine needle bed	None
Bark	Stone pine needle bed	0.8 m/s
Cone	Maritime pine needle bed	2.5 m/s
Cone scale	Southern blue gum leaf bed	4.5 m/s
Stone pine twig	Cured grass bed	
Bark		
Cone scale		
Maritime pine bark		
Cone scale		
Monterey pine bark		
Holm oak leaf		
Acorn		
Cork oak bark		
Southern blue gum bark		
Leaf		

Table 7-3—Probability of ignition for Mediterranean fuels, as a function of fuel bed bulk density and fuel moisture^a

Bulk density (kg/m ³)	Fuel moisture					
	1	3	5	7	9	11
	<i>Percent</i>					
10	79	74	69	62	56	49
20	84	80	75	69	63	57
30	88	85	81	76	70	64
40	91	88	85	81	77	71
50	93	91	89	86	82	77
60	95	93	92	89	86	82
70	97	95	94	92	89	87

^a Based on the work of Ganteaume et al. 2009.

embers are cooler than flaming, and that therefore the ignition delay time for glowing embers would be longer. The equations Muraszew developed are useful for research but require a value for the total heat flux from the ember and so are not useful in a field or operational context. The results are still of use in the field, however, because they provide an estimate of ignition delay time and how it depends on recipient fuel size and moisture. Using fuel properties appropriate for chaparral, fuel moisture between 2 and 10 percent, and fuel diameters between 0.2 and 4 cm, the model predicted ignition delay times from less than a second (fine, dry fuels) to near 50 s (coarse, moist fuels). The calculations also assumed no wind, which would increase the ignition delay time when combined with the other model assumptions.

Guijarro et al. (2002) and Ganteaume et al. (2009), previously mentioned in the discussion of ignition probability, also studied ignition delay time. They examined combinations of ember type, fuel bed type, flaming versus glowing embers, and glowing embers with or without wind. These experiments showed that ignition delay for flaming embers ranged from 1 s to about a minute. Glowing embers, as expected, produced longer ignition delay times. These ranged from 3 to 266 s with a wind of 0.8 m/s. Increasing wind to 2.5 m/s increased ignition delay time slightly, and further increasing wind to 4.5 m/s decreased ignition delay

time. In all cases, however, glowing embers' ignition delay times were on the order of a minute. Increasing fuel bed moisture from 0 to 4 percent increased ignition delay times by a factor of 1.2 to 1.5, but times were still on the order of a minute.

Alexander and Cruz (2006) illustrated the impact of ignition delay time on the potential for spot fires to establish beyond the overrun zone (fig. 7-5). The studies mentioned previously all produced ignition delay times of 4 min or less, so the lower two lines of the figure are most relevant. They show the minimum distance an ember must land ahead of the flaming front in order to establish as a new fire before that front overruns it. These distances are all in the realm of what the lofting literature would consider short, or nonvortex spotting distances.

Spot Fire Prediction Tools

Pastor et al. (2003) include spot fire models in their overview of all types of fire-spread models. Including all types of models, not just operationally usable tools, they identified eight spotting models. Of those eight, three are currently in operational use in the United States. The others are either more suited to research, or are not known to be in use at present.

The work of Tarifa et al. (1965, 1967), Muraszew (1974), and Muraszew et al. (1975, 1976) was funded by the U.S. Department of Agriculture Forest Service with the goal of creating a tool for spot fire prediction. Muraszew and Fedele (1976) outlined and described the culmination of that work—a system that would predict how many embers are produced, their size, and how far they would travel (both with a regular convection column and with vortex lofting) and the probability that one or more embers would ignite fuels or coalesce into a new fire. While some elements were not implementable (vortex lofting required detailed knowledge of airflow around the fire, for example), others appear to be. The system, however, is not directly part of any existing fire behavior tool.

Some elements of these studies went into three tools produced by Albini (1979, 1981, 1983b). These, in turn, are all incorporated into BehavePlus (Andrews 2007). Each of these tools predicts a maximum likely spotting distance for

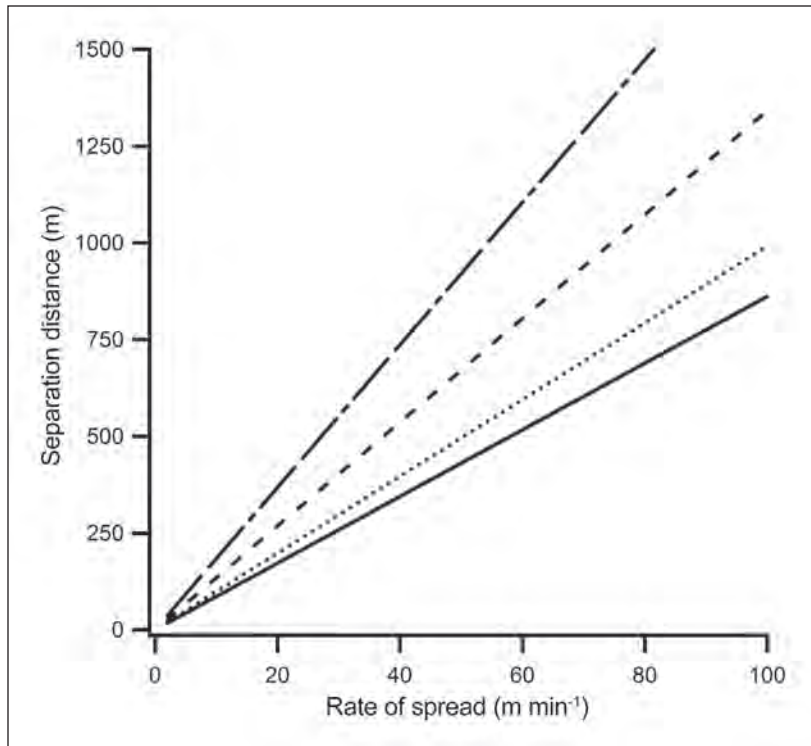

Figure 7-5—Minimum distance at which a spot fire will not be overrun by the main fire. Distance depends on ignition delay and is shown for delays of 0.2 minutes (solid line), 1.5 minutes (dotted line), 5 minutes (dashed line), and 10 minutes (short and long dash line). Following Alexander and Cruz (2006).

nonvortex lofted cylindrical embers, but the tools are for different types of fires. Albini (1979) is designed for embers lofting from 1 to 30 torching trees. This is the model used for spotting in the FARSITE fire spread model (Finney 2004). The next tool, Albini (1981), modified the lofting calculations to allow for burning slash piles or fuel jackpots, a more sustained plume driver. Albini (1983b) added a linear grass fire as a possible heat source (Morris 1987 provided a simplification). This model only applies when there is no timber cover, and relies heavily on a theoretical model of surges in grass fire intensity. Albini explicitly stated “this hypothesis, crucial in the model’s development, is unlikely to ever be tested directly.” All of the Albini models assume that wind direction is constant with height and that wind-speed increases according to theoretical models of the atmospheric boundary layer in the absence of fire.

While the Albini tools are built into BehavePlus and FARSITE and are based on extensive laboratory studies cited earlier, they have not been methodically or rigorously

tested in the field—indeed, it is practically impossible to do so, as one cannot know for certain that no embers landed beyond the calculated distance, unless the embers actually cause ignition. Even if a spot fire occurs beyond the model-predicted distance, there is no way to know whether it was lofted by a vortex. Norum (1982) and Rothermel (1983) each used anecdotal spotting events to favorably evaluate the Albini models, but Ellis (2000) cited several instances where spot fires initiated far beyond where Albini’s model predicts they would.

Bunting and Wright’s (1974) results provide limited guidance on spotting distance and fuel break widths for burning slash piles of juniper. Their general conclusions suggest 100-ft fuel breaks or spotting distances for air temperatures below 60 °F, but their equation for that distance depends strongly on temperature above 60 °F. The equation produces a distance of 48 ft at 60 °F; then, 205 ft at 70 °F, and 870 ft at 80 °F. This illustrates the potential problems of applying equations or models near or beyond the limits under which they were developed.

Wilson (1988) included two figures that provided guidance on fire break widths to prevent spotting (fig. 7-6). These came out of field observations of grass fires in Australia’s Northern Territory and are valid for situations with no trees, or only scattered, sparse trees, comparable to fuel models 1 and 3 in Anderson (1982) or Scott and Burgan (2005).

Figure 7-2, discussed earlier from Alexander and Cruz (2006) also qualifies as a tool. It serves for estimation of the depth of the overrun zone, which can be considered the region where spot fire suppression has limited effect. There is little advantage in trying to suppress fires that will be overrun before they establish (this calculation is also part of the Crown Fire Initiation and Spread [CFIS] System discussed in the crown fire chapter of this document and described in Alexander et al. 2006.)

Rascher (2003) provided suggested scales for fire breaks to prevent spotting in saltcedar and juniper/oak stands. As noted previously, saltcedar spotted more than juniper/oak in these burns. In both types of vegetation, however, the maximum spotting distance observed was about 150 m. Accompanying winds were between 5 and 8 mi/h.

In terms of ignition probability, Muraszew and Fedele (1976) relied on the ignition probability table from the 1974 National Fire Danger Rating System. Currently, the equivalent to that table is table 12 of the Fireline Handbook, Appendix B. Albini (1979) also included a table for spotting potential that gives qualitative rating of the ease of ignition.

Weir (2004) discussed spotting probability based on observations in a number of vegetation types in Oklahoma. Spotting probability in these observations is not ignition probability. The latter does not consider whether an ember lands to possibly cause ignition, it only looks at the probability of ignition assuming there is an ember. Weir looked at the frequency of actual spot fire development on 99

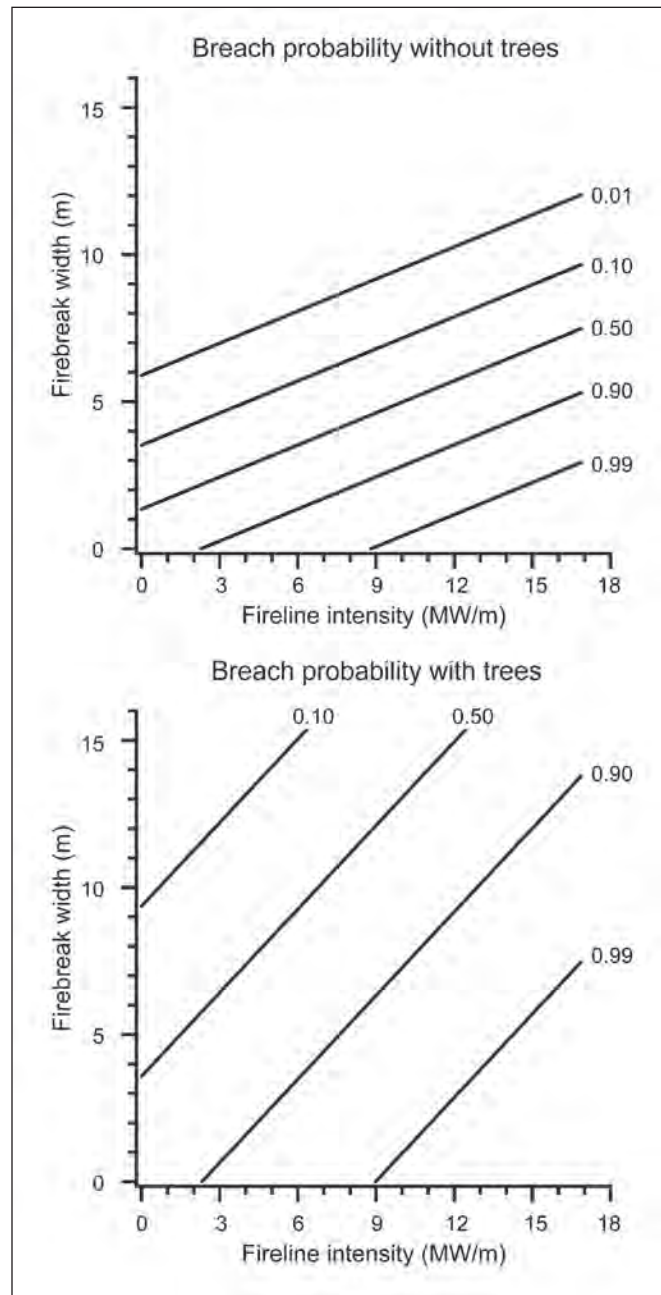

Figure 7-6—Probability estimates for grass fires to breach fire-breaks of a specified width. Probability depends on the presence or absence of trees in the grass stand, and on fireline intensity. Based on equations in Wilson (1988).

prescribed fires. He concluded that ignition occurred on all fires when relative humidity was below 25 percent, and very rarely (once) when relative humidity exceeded 40 percent. This guidance is perhaps valuable for prescribed fires, but not particularly limiting for wildland fire conditions, when relative humidity below 25 percent is common.

In fuel types similar to those in Ganteaume (2009), the probability equations presented therein or table 7-3 may be suitable. Caution is necessary, however, because their equations were derived for specific fuels and have not been tested or applied to other fuels, even similar ones, nor have they been evaluated outside of the laboratory.

Knowledge Gaps

Koo et al. (2010) identified several gaps in our understanding of spotting. Koo et al. focused on ember generation and on ignition potential for embers that land. They considered resolution of the airflow relatively well known and not as important for research at present. They also identified the need to understand the transition between smoldering and flaming combustion for embers as a lesser, but nonetheless important area for further research. Some of the work in Ellis (2000), not discussed here, confirms the complexity and need for this work.

From this review, four primary areas for further research are apparent. The first is the issue of ember generation identified by Koo et al. If spot fire tools are going to broaden their application beyond just maximum spotting distance to cover the numerous, nearby spot fires that can occur just beyond the overrun zone, then field observations of the number and size of embers produced by various fuel types are essential. Without these, there is no way to know how many embers could be carried downwind, or how far downwind they will go. These are important factors for determining whether spotting will affect the fire's rate of spread and whether spot fires will be numerous enough to merge readily. Knowing how the number and size of embers vary by fuel type is important for understanding when spotting is of concern.

The second area needing more research is understanding the importance of the turbulent convective column and the true atmospheric conditions lofting and transporting

the embers. Tarifa (1967) stated "Fire spread by fire brands depends essentially on the convective currents and wind conditions in forest fires. Therefore, an accurate knowledge of these phenomena is absolutely required in order to apply correctly the information obtained from the basic studies of firebrands." Studies using coupled fire-atmosphere models, or at the least time-dependent, three-dimensional models are presently the best approach to understanding how the convective currents and the real atmosphere influence brand transport. Extremely long distance transport, long enough to reach the sailing/whirl zone in figure 7-1, involves lofting high enough that the directional changes in wind with height can lead to spotting to the sides of the surface winds, and should be at least tested for significance with some models.

The other aspect of long distance transport that has not been examined in any way is the shed-vortex transport described by Berlad and Lee (1968). Documenting or measuring this process on real fires would be extremely challenging but must precede any attempt to model it credibly. If observations confirm this process is occurring in nature, then models may be developed. While this vortex transport concept is in some ways novel, it appears on the surface to accommodate many of the aspects of long range spotting that are more difficult to explain otherwise.

Third, Sardoy et al. (2008) illustrated that char content is an important factor in determining spotting distance and the degree of separation between short- and long-distance spotting. Extension of the research in this area, especially in combination with more information on the number and size of embers for various fuel types, could aid in development of tools to predict the distances of greatest concern for spot fire monitoring or control. Work needed in this area includes laboratory or field measurement of char content by species, as well as modeling study of the relationship among char content, fire intensity, environmental windspeed, and separation distance.

Ignition delay, the end of the spotting life cycle, is the fourth area where research is important. Connecting the research on realistic ember sizes, and the fuel conditions that produce those embers, with information on recipient fuels and ignition delays associated with them, would clarify the

depth of the overrun zone. Perhaps more importantly, it is important in determining the likelihood of multiple embers starting spot fires that could merge and establish a new, independent fire front.

Project Vesta (Gould et al. 2007) demonstrated that many poorly known properties of spotting can indeed be studied in the field. That project captured spatial distributions in several ways, including contour plots and empirical functions for the across-wind and along-wind variations in landing embers. Similar projects could clearly be executed in different spotting-prone ecosystems.

Finally, there is one opportunity that may have substantial potential for benefit in the field. Muraszew and Fedele (1976) outlined a model for prediction of spot fire number and distance, as well as the potential for ignition and merging of multiple spot fires. The report implies that the model was actually put into a computer model at that time, but it seems to have stopped there. It is probably well worth the time and effort to reexamine their model in light of the last 35 years of research and determine whether it could be translated into an operational tool. Some components may not be viable, but many others may well be.

Literature Cited

- Albini, F.A. 1979.** Spot fire distance from burning trees—a predictive model. Gen. Tech. Rep. INT-56. Ogden, UT: U.S. Department of Agriculture, Forest Service, Intermountain Forest and Range Experiment Station. 25 p.
- Albini, F.A. 1981.** Spot fire distance from isolated sources—extensions of a predictive model. Res. Note INT-309. Ogden, UT: U.S. Department of Agriculture, Forest Service, Intermountain Forest and Range Experiment Station. 9 p.
- Albini, F.A. 1983a.** Potential spotting distance from wind-driven surface fires. Res. Pap. INT-309. Ogden, UT: U.S. Department of Agriculture, Forest Service, Intermountain Forest and Range Experiment Station. 27 p.
- Albini, F.A. 1983b.** Transport of firebrands by line-thermals. *Combustion Science and Technology*. 32: 277-288.
- Alexander, M.E.; Cruz, M.G. 2006.** Evaluating a model for predicting active crown fire rate of spread using wildfire observations. *Canadian Journal of Forest Research*. 36: 3015–3028.
- Alexander, M.E.; Cruz, M.G.; Lopes, A.M.G. 2006.** CFIS: a software tool for simulating crown fire initiation and spread. [CD-ROM]. In: Viegas, D.X., ed. *Proceedings of the 5th international conference on forest fire research*. Amsterdam, The Netherlands: Elsevier BV. 13 p.
- Anderson, H.E. 1982.** Aids to determining fuel models for estimating fire behavior. Gen. Tech. Rep. INT-122. Ogden, UT: U.S. Department of Agriculture, Forest Service, Intermountain Forest and Range Experiment Station. 22 p.
- Andrews, P.L. 2007.** BehavePlus fire modeling system: past, present, and future. In: *Proceedings of the 7th symposium on fire and forest meteorology*. Bar Harbor, MA: American Meteorological Society. 13 p. <http://ams.confex.com/ams/pdfpapers/126669.pdf>. (7 March 2014)
- Anthenien, R.A.; Tse, S.D.; Fernandez-Pello, A.C. 2006.** On the trajectories of embers initially elevated or lofted by small scale ground fire plumes in high winds. *Fire Safety Journal*. 41: 349–363.
- Berlad, A.L.; Lee, S.-L. 1968.** Long range spotting. *Combustion and Flame*. 12: 172–174.
- Bhutia, S.; Jenkins, M.A.; Sun, R. 2010.** Comparison of firebrand propagation prediction by a plume model and a coupled fire/atmosphere large-eddy simulator. *Journal of Advances in Modeling Earth Systems*. (2): Article 4. doi:10.3894/JAMES.2010.2.4
- Blackmarr, W.H. 1972.** Moisture content influences ignitability of slash pine litter. Res. Note RN-SE-173. Asheville, NC: U.S. Department of Agriculture, Forest Service, Southeastern Forest Experiment Station. 7 p.

- Brown, A.A.; Davis, K.P. 1973.** Forest fire control and use. 2nd ed. New York: McGraw-Hill. 686 p.
- Bunting, S.C.; Wright, H.A. 1974.** Ignition capabilities of non-flaming firebrands. *Journal of Forestry*: 646–649.
- Byram, G.M. 1959.** Forest fire behavior. In: Davis, K.P., ed. Forest fire control and use. New York: McGraw Hill: 90–123.
- Colin, P.Y.; Lampin-Cabaret, C.; Delboulbe, E.; Coste, N.; Marcillat, J.; Pereira, J.C.; Binggeli, F.; Gaulier, A.; Botelho, H.; Loureiro, C.; Loddo, G.; Ditana, E.; Vega, J.A.; Gorostiaga, P.; Alexandrian, D.; Dimitrakopoulos, A. 2002.** SALTUS program—spot fires. Knowledge and modeling. In: Viegas, D., ed. Forest fire research and wildland fire safety. Proceedings, IV conference on forest fire research: wildland fire safety summit. Rotterdam, The Netherlands. Millpress, Rotterdam: 18–23.
- Countryman, CM. 1974.** Can Southern California wildfire conflagrations be stopped? Gen. Tech. Rep. PSW-7. Berkeley, CA. U.S. Department of Agriculture, Forest Service, Pacific Southwest Research Station. 11 p.
- Ellis, P.F. 2000.** The aerodynamic and combustion characteristics of eucalypt bark—a firebrand study. Canberra, ACT, Australia: Australian National University. 187 p. Ph.D. thesis.
- Finney, M.A. 2004.** FARSITE: fire area simulator—model development and evaluation. Res. Pap. RMS-RP-4. Ogden, UT: U.S. Department of Agriculture, Forest Service, Rocky Mountain Research Station. 47 p.
- Ganteaume, A.; Lampin-Maillet, C.; Guijarro, M.; Hernando, C.; Jappiot, M.; Fonturbel, T.; Pérez-Gorostiaga, P.; Vega, J.A. 2009.** Spot fires: fuel bed flammability and capability of firebrands to ignite fuel beds. *International Journal of Wildland Fire*. 18: 951–969.
- Gellie, N.; Gabos, K.; Mattingley, G.; Wells, T.; Salkin, O. 2010.** Reconstructing the spread and behavior of the February 2009 Victorian fires. In: Proceedings, 3rd fire behavior and fuels conference. Birmingham, AL: International Association of Wildland Fire. 24 p.
- Gould, J.S.; McCaw, W.L.; Cheney, N.P.; Ellis, P.F.; Knight, I.K.; Sullivan, A.L. 2007.** Project Vesta—fire in dry eucalypt forests: fuel structure, fuel dynamics, and fire behaviour. Perth, WA: Ensis-CSIRO, Canberra ACT and Department of Environment and Conservation. 218 p.
- Guijarro, M.; Hernando, C.; Diez, C.; Martinez, E.; Madrigal, J.; Lampin Cabaret, C.; Blanc, L.; Colin, P.Y.; Perez-Gorostiaga, P.; Vega, J.A.; Fonturbel, M.T. 2002.** Flammability of some fuel beds common in the South-European ecosystems. In: Viegas, D.X., ed. Forest fire research and wildland fire safety. Proceedings, IV conference on forest fire research: wildland fire safety summit. Rotterdam, The Netherlands: Milpress Scientific Publications: 152.
- Koo, E.; Pagni, P.J.; Linn, R.L. 2007.** Using FIRETEC to describe firebrand behavior in wildfires. In: The 10th international symposium of fire and materials. London, United Kingdom: Interscience Communications.
- Koo, E.; Pagni, P.J.; Weise, D.F.; Woycheese, J.P. 2010.** Firebrands and spotting ignition in large-scale fires. *International Journal of Wildland Fire*. 19: 818–843.
- Lee, S.L.; Hellman, J.M. 1969.** Study of firebrand trajectories in a turbulent swirling natural convection plume. *Combustion and Flame*. 15: 645–655.
- Lee, S.L.; Hellman, J.M. 1970.** Firebrand trajectory study using an empirical velocity-dependent burning law. *Combustion and Flame*: 15: 265–274.
- Linn, R.R.; Reisner, J.; Colman, J.J.; Winterkamp, J. 2002.** Studying wildfire behavior using FIRETEC. *International Journal of Wildland Fire*. 11: 233–246.

- Manzello, S.L.; Cleary, T.G.; Shields, J.R.; Yang, J.C. 2006.** On the ignition of fuel beds by firebrands. *Fire and Materials*. 30: 77–87.
- Manzello, S.L.; Maranghides, A.; Mell, W.E. 2007a.** Firebrand generation from burning vegetation. *International Journal of Wildland Fire*. 16: 458–462.
- Manzello, S.M.; Maranghides, A.; Shields, J.R.; Mell, W.E.; Hayashi, Y.; Nii, D. 2007b.** Mass and size distribution of firebrands generated from burning Korean pine (*Pinus koraiensis*) trees. *Fire and Materials*. 33: 21–31.
- Morris, G.A. 1987.** A simple method for computing spotting distances from wind-driven surface fires. Res. Note INT-374. Ogden, UT: U.S. Department of Agriculture, Forest Service, Intermountain Research Station. 7 p.
- Muraszew, A. 1974.** Firebrand phenomena. Aerospace Report ATR-74(8165-01)-1. El Segundo, CA: The Aerospace Corporation. 109 p.
- Muraszew, A.; Fedele, J.B. 1976.** Statistical model for spot fire hazard. Aerospace Report ATR-77(7588)-1. El Segundo, CA: The Aerospace Corporation. 109 p.
- Muraszew, A.; Fedele, J.B.; Kuby, W.C. 1975.** Firebrand investigation. Aerospace Report ATR-74(7470)-1. El Segundo, CA: The Aerospace Corporation. 104 p.
- Muraszew, A.; Fedele, J.B.; Kuby, W.C. 1976.** Investigation of fire whirls and firebrands. Aerospace Report ATR-76(7509)-1. El Segundo, CA: The Aerospace Corporation. 155 p.
- Norum, R.A. 1982.** Predicting wildfire behavior in black spruce forests in Alaska. Res. Note PNW-401. Portland, OR: U.S. Department of Agriculture, Forest Service, Pacific Northwest Forest and Range Experiment Station. 10 p.
- Pastor, E.; Zarete, L.; Planas, E.; Arnaldos, J. 2003.** Mathematical models and calculation systems for the study of wildland fire behaviour. *Progress in Energy and Combustion Science*. 29: 139–153.
- Perryman, H. 2009.** A mathematical model of spot fires and their management implications. Arcata, CA: Humboldt State University. 108 p. M.S. thesis.
- Rascher, B. 2003.** Prescription development for burning two volatile fuel types. Lubbock, TX: Texas Tech University. 72 p. Ph.D. dissertation.
- Rothermel, R.C. 1983.** How to predict the spread and intensity of forest and range fires. Gen. Tech. Rep. INT-143. Ogden, UT: U.S. Department of Agriculture, Forest Service, Intermountain Forest and Range Experiment Station. 161 p.
- Sardoy, N.; Consalvi, J.-L.; Kaiss, A.; Fernandez-Pello, A.C.; Porterie, B. 2008.** Numerical study of ground-level distribution of firebrands generated by line fires. *Combustion and Flame*. 154: 478–488.
- Sardoy, N.; Consalvi, J.-L.; Porterie, B.; Fernandez-Pello, A.C. 2007.** Modeling transport and combustion of firebrands from burning trees. *Combustion and Flame*. 150: 151–169.
- Scott, J.H.; Burgan, R.E. 2005.** Standard fire behavior fuel models: a comprehensive set for use with Rothermel's surface fire spread model. Gen. Tech. Rep. RMRS-GTR-153. Fort Collins, CO: U.S. Department of Agriculture, Forest Service, Rocky Mountain Research Station. 72 p.
- Sun, R.; Krueger, S.K.; Jenkins, M.A.; Charney, J.J. 2009.** The importance of fire/atmosphere coupling and boundary layer turbulence to wildfire spread. *International Journal of Wildland Fire*. 18: 50–60.
- Tarifa, C.S.; del Notario, P.P.; Moreno, F.G. 1965.** On the flight paths and lifetimes of burning particles of wood. Tenth symposium (international) on combustion: 10: 1021–1037.
- Tarifa, C.S.; del Notario, P.P.; Moreno, F.G.; Villa, A.R. 1967.** Transport and combustion of firebrands. Final report of grants FG-SP-114 and FG-SP-146. Madrid, Spain: Instituto Nacional de Tecnica Aeroespacial. 90 p. Vol. II.

Tse, S.D.; Fernandez-Pello, A.C. 1998. On the flight paths of metal particles and embers generated by power lines in high winds and their potential to initiate wildland fires. *Fire Safety Journal*. 30: 333–356.

Wade, D.D.; Ward, D.E. 1973. An analysis of the Air Force bomb range fire. Res. Pap. SE-105. Asheville, NC: U.S. Department of Agriculture, Forest Service, Southeast Forest Experiment Station. 38 p.

White, R.H.; Zipperer, W.C. 2010. Testing and classification of individual plants for fire behavior. *International Journal of Wildland Fire*. 19: 213–227.

Wilson, A.A.G. 1988. Width of a firebreak that is necessary to stop grass fires: some field experiments. *Canadian Journal of Forest Research*. 18: 682–687.

Chapter 8: Vortices and Wildland Fire

Jason M. Forthofer¹ and Scott L. Goodrick²

Introduction

Large fire whirls are often one of the more spectacular aspects of fire behavior. Flames flow across the ground like water feeding into the base of the vortex, the lowest thousand feet of which often takes on an orange glow from combusting gases rising within the vortex core. Burning debris lofted within the vortex can lead to a scattering of spot fires some distance from the main fire. With their sudden formation, erratic movement, and often sudden dissipation, fire whirls are a good example of extreme fire behavior. However, other forms of vortices are actually quite common on wildland fires and receive less attention despite their potential to dramatically alter fire behavior.

This chapter is designed to provide a better understanding of vortices associated with wildland fires, both fire whirls and horizontal roll vortices. A key point will be providing a basic understanding of what aspects of the fire environment contribute to the development and growth of these vortices. The next section of the chapter supplies a brief introduction to vorticity, a measure of the atmosphere's tendency to spin or rotate about some axis. With this basic understanding of vorticity, we will examine the common vortex forms described in the fire behavior literature, fire whirls and horizontal roll vortices.

Vorticity Basics

Vorticity is the measure of spin about an axis. That axis can be vertical, as in the case of a fire whirl, or horizontal for a roll vortex, or somewhere in between. Mathematically, vorticity is a vector quantity (it has both magnitude and

directional information) that is defined as the curl of the wind field.

$$\vec{\omega} = \Delta \times \vec{V} \quad (1)$$

or in component form.

$$\vec{\omega} = \left(\frac{\partial w}{\partial y} - \frac{\partial v}{\partial z} \right) \hat{i} + \left(\frac{\partial u}{\partial z} - \frac{\partial w}{\partial x} \right) \hat{j} + \left(\frac{\partial v}{\partial x} - \frac{\partial u}{\partial y} \right) \hat{k} \quad (2)$$

As a simple hypothetical example, take a cross section through a fire with no ambient horizontal winds (fig. 8-1). The vertical winds near the ground can be characterized by a strong updraft over the fire and descending air outside of the fire area. The change in the vertical velocity along the x-axis imparts rotation to the flow field about the y-axis. Note that this does not describe how vorticity is generated, but rather just illustrates the definition. The complete vorticity equation can be derived by applying equation (1) to the Navier-Stokes equations that describe fluid motions to get

$$\begin{aligned} \frac{\partial \vec{\omega}}{\partial t} + (\vec{V} \cdot \nabla) \vec{\omega} &= (\vec{\omega} \cdot \nabla) \vec{V} - \vec{\omega} (\nabla \cdot \vec{V}) + \\ & \frac{1}{\rho^2} \nabla \rho \times \nabla p + \nabla \times \left(\frac{\nabla \cdot \tau}{\rho} \right) + \nabla \times \vec{B} \end{aligned} \quad (3)$$

The first term on the left hand side of equation (3) is the time rate of change of vorticity at a point. All of the remaining terms in the equation describe processes by which the vorticity at a point is changed. The second term on the left hand side is the advection, or transport, of vorticity by the wind. Thus vorticity generated in one place can affect another location.

The right hand side of equation (3) begins with the tilting term, $(\vec{\omega} \cdot \nabla) \vec{V}$, that describes how velocity gradients can transform horizontal vorticity into vertical vorticity and vice versa. The second term on the right hand side, $\vec{\omega} (\nabla \cdot \vec{V})$, describes how flow convergence (divergence) stretches (compresses) vortices and increases (decreases) the magnitude of the vorticity. Note that these tilting and

¹ Jason M. Forthofer is a mechanical engineer, U.S. Department of Agriculture, Forest Service, Missoula Fire Sciences Laboratory, 5775 US West Highway 10, Missoula, MT 59808.

² Scott L. Goodrick is a research meteorologist, U.S. Department of Agriculture, Forest Service, Southern Research Station, 320 Green Street, Athens, GA 30602.

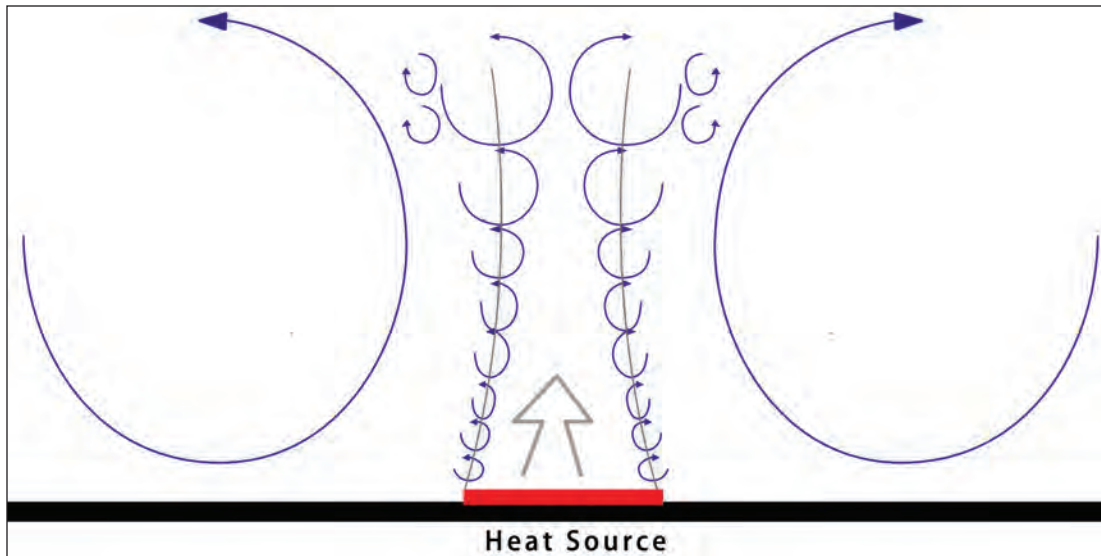

Figure 8-1—Cross section through idealized fire illustrating occurrence of vortices owing to horizontal gradient of vertical motion produced by buoyancy from the fire.

stretching terms can only enhance the vorticity already present in the flow; they cannot generate new vorticity. The solenoidal or baroclinic term is the third term on the right hand side of equation (3), $\frac{1}{\rho^2} \vec{\nabla} \rho \times \vec{\nabla} p$. This term generates vorticity in cases where the gradients in pressure and density are not parallel. In the case of a fire, rapid heating develops a horizontal temperature gradient that is not aligned with the vertical static pressure gradient. This misalignment of the vertical pressure gradient and horizontal thermal gradient leads to rotational motions to mix warm and cold fluid to restore balance.

The fourth term in equation (3), $\vec{\nabla} \times \left(\frac{\vec{\nabla} \cdot \boldsymbol{\tau}}{\rho} \right)$, provides for the generation of vorticity by viscous shear stress. Wind shear induced by surface drag is a source of vorticity; therefore, if the wind is blowing at the Earth's surface, horizontal vorticity is being generated. The final term in equation (3), $\vec{\nabla} \times \vec{B}$ represents changes in vorticity owing to body forces such as gravity acting on the fluid.

In summary, the vorticity at any location changes as a result of the transport of vorticity from one place to another, the tilting of vorticity from one axis to another, the stretching and intensifying of vortices by convergence, or by the generation of vorticity through buoyancy or wind shear.

Fire Whirls

Fire whirls are vertically oriented, intensely rotating columns of gas found in or near fires. They have been observed in wildland, urban, and oil spill fires and volcanic eruptions. Dynamically they are closely related to other swirling atmospheric phenomena such as dust devils, waterspouts, and tornados (Emmons and Ying 1967). Fire whirls have also been called fire devils, fire tornados, and even fire-nados. They are usually visually observable because of the presence of flame, smoke, ash, or other debris. The definition of a fire whirl used here includes those whirls caused by the buoyancy of a fire but with no inner core of flame. Fire whirls range in size from less than 1 m in diameter and velocities less than 10 m/s up to possibly 3 km in diameter and winds greater than 50 m/s (Goens 1978). The smaller fire whirls are fairly common, while the larger whirls are less common. All fire whirls, especially the larger ones, represent a considerable safety hazard to firefighters through increased fire intensity, spotting, erratic spread rate and direction, and wind damage (Emori and Saito 1982, Moore 2008, USDI BLM 2006).

Several extremely large fire whirls have been reported in urban fires that illustrate their potentially destructive

nature. In 1871, the Great Chicago Fire generated whirlwinds that lifted and transported burning planks 600 m ahead of the main fire, which contributed greatly to the spread and destruction of the fire (Musham 1941). On the same day, a fire in Peshtigo, Wisconsin, generated a whirl that was strong enough to lift a house off its foundations (Gess and Lutz 2002). Hissong (1926) also reported a whirl strong enough to move a house. This whirl was one of many that formed during a large oil storage facility fire. The whirl separated from the fire and moved 1000 m downwind, lifted a small house, and moved it 45 m killing the two residents inside. A much more devastating whirl formed in 1921 when a magnitude 7.9 earthquake hit the Tokyo, Japan, area causing a mass urban fire. This fire spawned an extremely large fire whirl that killed an estimated 38,000 people in less than 15 minutes (Soma and Saito 1988). The victims had gathered in an area of sparse fuel 0.16 km² in size and the whirl moved over the area. Last, the World War II city bombings of Hamburg, Dresden, and Hiroshima were reported to have caused very large and destructive fire whirls. The Hamburg whirl was estimated at 2.4 to 3 km in diameter and 5 km tall (Ebert 1963).

Large and intense fire whirls also occur on wildland fires. Graham (1952, 1955, 1957) described several large whirls that were able to lift large logs and other debris and break off large standing trees. He indicated that many form on lee slope locations. Pirsko et al. (1965) reported on a very intense fire whirl that moved out of the fire area in the downwind direction and destroyed two homes, a barn, three automobiles, toppled almost 100 avocado trees, and injured four people. They also believe that the terrain and lee slope location contributed to the formation of the whirl. Additionally, they cite moderate winds, an unstable atmosphere, and a large heat source as contributors. King (1964) analyzed video of a fire whirl and found that maximum vertical velocities in the whirl core were up to 91 m/s (0.05 mi/s). Large fire whirls have also been documented on flat ground. Haines and Updike (1971) described several medium to large size fire whirls that occurred during prescribed fires on flat ground. They cited a super-adiabatic lapse rate in the lower atmosphere as an important factor.

Umscheid et al. (2006) also reported on a large fire whirl that occurred on flat ground and gave convincing arguments that a major contributor to the whirl was vorticity associated with passage of a cold front. Billing and Rawson (1982) also reported on a large whirl that may have been influenced by a cold front passage. McRae and Flannigan (1990) described many large whirls that occurred on prescribed fires. One of the largest and most intense whirls was 400 m in diameter and ripped standing trees out of the ground and lifted them upwards. This whirl occurred on a cloudy day with a temperature lapse rate of 6 °C/1000 m in the first 1000 m above the ground. They concluded that the influence of the environmental lapse rate on fire whirl formation is unclear and that whirls can form under lapse rates other than dry or super adiabatic.

Fire whirls have severely injured firefighters in the past. Emori and Saito (1982) describe a wildland fire in Japan that may have spawned a fire whirl that injured firefighters. The 2001 Fish Fire in Nevada generated a fire whirl that caused firefighters to deploy their fire shelters (USDI BLM 2001). Another whirl in 2006 in Nevada injured six firefighters (USDI BLM 2006). Finally, a very large whirl formed on the 2008 Indians Fire in California that injured four firefighters (Moore 2008).

Fire Whirl Physics

Over the past few decades, a significant body of information has accumulated on fire whirl structure and influencing factors. The different techniques used to investigate fire whirls include field- and laboratory-scale experiments, and analytical, physical, and numerical modeling. This work has revealed some of the main features of fire whirls. For example, it is commonly accepted that the formation of fire whirls requires a source of ambient vorticity and a concentrating mechanism (Emmons and Ying 1967, Goens 1978, Meroney 2003, Zhou and Wu 2007). Ambient vorticity in the atmosphere can be generated by the ground boundary layer of wind, by wind shear from nonuniform horizontal densities, and from the Earth's rotation. The concentrating mechanisms in fires are produced by the buoyant flow. It reorients horizontal vorticity into the vertical direction and provides vortex stretching.

Whirl structure—

One of the first laboratory studies of fire whirls was that of Emmons and Ying (1967). They were able to generate a fire whirl with a combustive core by placing a liquid-fueled (acetone) pool fire in a cylindrical rotating screen. The rotation speed of the screen was varied and temperature, velocity, and burning rate were measured. Several important aspects of fire whirls were identified in this study. They found that a fire whirl develops an ascending and rotating core of fuel-rich gas. The core's radial distribution of tangential velocity may be in more or less "solid body" rotation (also called a forced vortex), but Emmons and Ying were not able to take measurements to prove this. In a forced vortex, vorticity and angular frequency are constant and nonzero. Tangential velocity and circulation increase with radius. Outside of this core, Emmons and Ying described a fuel-lean area with tangential velocity that can be well described by a free or potential vortex plus small radial and vertical

velocity components. Vorticity in a free vortex is zero, while angular velocity and frequency tend toward zero with distance from the axis. Snegirev et al. (2004) stated that the free and forced vortex system can be approximated with the Rankine vortex shown in figure 8-2, which is apparently common in other vortices in rotating fluids. Their numerical model, which used a k-epsilon turbulence closure modified for swirling flows, did indeed show that the radial profile of tangential velocity closely resembled the Rankine vortex. Chuah and Kushida (2007) and Chuah et al. (2009) used a Burger's vortex for the core flow. A Burger's vortex is an exact analytical solution to the Navier-Stokes equations that is sometimes used to describe vortex tubes. They also stated that the radial inflow velocity needed to maintain the vortex is a function of the core radius with a smaller core radius requiring more radial inflow to maintain the vortex.

Akhmetov et al. (2007) used a particular image velocimetry method on a laboratory-generated fire whirl

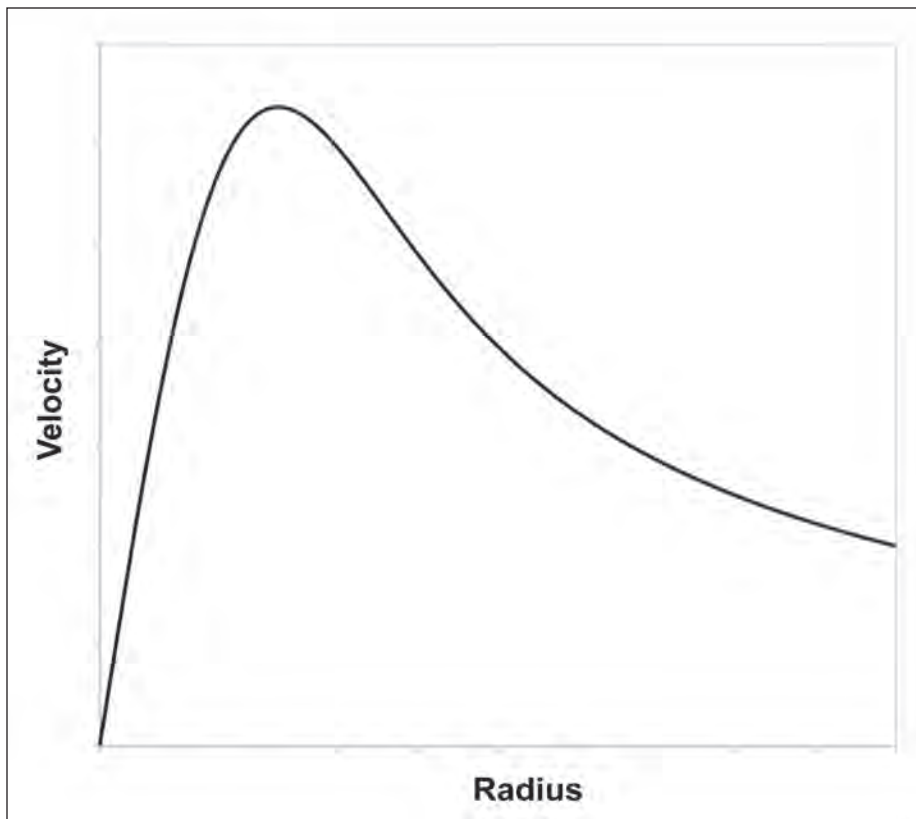

Figure 8-2—Tangential velocity structure as a function of radius for a Rankine vortex.

to provide currently the best measurements of the velocity structure in a fire whirl. They confirmed that a fire whirl generates a core region that rotates in approximately solid body rotation. The maximum vertical velocity in the core region was of the same order of magnitude as the maximum rotational component. Outside of the core, the rotational velocity component decreases with distance from the axis, and vertical velocities are much less. They also concluded that the basic features of fire whirl flows are the same as in other vertical tornado-like vortices such as dust devils and tornados.

Turbulent mixing—

Emmons and Ying (1967) also found that the rotational motion in and at the boundary of a fire whirl core causes an order of magnitude reduction in turbulent mixing motions. This is what gives a fire whirl its tall, slender appearance. They indicate that this turbulent mixing reduction is a very significant aspect of swirling flows and one of the main reasons fire whirls are able to achieve such strong intensities. Snegirev et al. (2004) expanded on the turbulent suppression idea explaining that, in the core, radial displacement of a fluid particle towards the axis is resisted by centrifugal acceleration, and displacement away from the axis is resisted by the radial pressure gradient. Because of the solid body rotation in the core, this radial pressure gradient increases with radius. The turbulence suppression in the core is analogous to that in a stable atmospheric boundary layer, but with different resisting forces. In the outer, free vortex area, fluctuations in the radial direction are destabilized, analogous to an unstable atmospheric boundary layer. Others (Beer et al. 1971, Chigier et al. 1970) have examined turbulence in laboratory fire whirls and jets in more detail and also showed a large reduction in turbulence in the whirl core. Some have proposed the use of a Richardson number for examining the stability of fire whirls (Beer et al. 1971, Snegirev et al. 2004).

Emmons and Ying (1967) indicated that the stable core environment could lead to the existence of “surface waves” on the surface of the core, similar to water flowing in a river or stable atmospheric flow over a hill. In the case of the upward flow being faster than the surface wave speed (“shooting flow”), a hydraulic jump type situation is

possible (Meroney 2003). This jump from so-called “shooting flow” to “tranquil flow” (flow speed slower than wave speed) would be accompanied by high turbulence, which could contribute to vortex breakdown, although this has never been confirmed. Emmons and Ying (1967) also mentioned that a hydraulic jump may be necessary if the whirl is to satisfy its ground-level and “high”-altitude boundary conditions for momentum and mass flow. This might be similar to water flowing down a dam spillway, where the initial velocity is high (supercritical flow) but it flows into an environment of much slower flow (subcritical flow) at the end of the spillway. The flow must form a hydraulic jump to satisfy these boundary conditions in a stable flow environment. Komurasaki et al. (1999) used numerical simulation to investigate vortex breakdown in a thermal whirl and found that just as vortex breakdown begins, strong vorticity appears near the ground. This strong vorticity was attributed to strong jets of downward-moving air that impinge on the ground during the breakdown of the simulated whirl, which, if true, could have safety implications for nearby firefighters.

Note that several authors have found that, at very low rotation, a plume actually expands more than the nonrotating plume and reduces the flame height. As rotation is increased, turbulence is suppressed as discussed above and the plume expands less than the nonrotating plume giving a taller, more slender plume. Emmons and Ying (1967) showed this in their figure 7, but cannot explain this behavior. Battaglia et al. (2000) also showed this behavior in their numerical model. Zhou and Wu (2007) explained this by stating that it is due to the inflow boundary layer wind reducing the initial vertical velocity of gas and enhancing entrainment.

The large reduction of turbulent mixing in the core of a whirl is one of the principle causes of the amazing velocities fire whirls can achieve. The low turbulence reduces transfer of momentum, mass (density), fuel, and oxygen to and from the core. In whirls with a combusting core, this causes a large increase in flame lengths because the flames are turbulent diffusion flames and mixing with oxygen outside the core is limited. Emmons and Ying (1967) reported flame length increases of up to seven times the nonwhirl lengths,

although the increased flame lengths included the combined effect of turbulent reduction in the whirl core and increased evaporation rates of the acetone pool. Chigier et al. (1970) used a metered methane burner to keep gas flow rates constant and showed that flame lengths doubled in their laboratory whirl produced using a rotating mesh cylinder. Because the fuel flow was held constant, this increase in flame lengths was due solely to the reduction in mixing. Even in whirled with noncombusting cores, this low turbulent mixing produced a tall column of lower density gas than the surroundings. Consequently, pressure at the ground level in the core may be very low (Emmons and Ying 1967) because of decreased hydrostatic pressure. This combines with the cyclostrophic flow effect discussed in the next section to produce extremely low pressures near the ground.

Cyclostrophic flow—

Contributing to a low pressure in the core is the roughly cyclostrophic flow (pressure gradient force balances the centrifugal force) (Jenkins et al. 2001). As the whirl spins faster, lower pressures occur in the core to balance the increased centrifugal force. Near the ground, this cyclostrophic balance is disrupted by drag forces, and the large radial pressure gradient produces flow toward the axis of rotation. Consequently, flow near the ground converges toward the center of the whirl and then is forced vertically. This draws air, rich in shear-produced horizontal vorticity, into the bottom of the whirl (Meroney 2003). Also, additional buoyant gases and fuel may be drawn into the core, aiding vortex stretching (Emmons and Ying 1967). Muraszew et al. (1979) stated that this effect, a result of the ground surface, is a requirement for the formation of a fire whirl.

Vortex stretching—

The primary vorticity-concentrating mechanism in fire whirled appears to be vortex stretching caused by vertically accelerating flow in the whirl core (Snegirev et al. 2004). This corresponds to the second term on the right-hand side of the vorticity transport equation (equation 3). The vertical acceleration is due to buoyant forces from hot gases in the core of the fire whirl. This acceleration causes a reduction in the diameter of a horizontal area enclosed by a chain of fluid

particles (horizontal convergence), thereby increasing non-zero vorticity at any location on the horizontal area (Jenkins et al. 2001). This is analogous to a reduction in the moment of inertia of a rotating solid, causing increased rotation rate to conserve angular momentum. Snegirev et al. (2004) indicated that the whirl core radius is not dependent on the initial or imposed circulation, but that it is probably dependent on vortex stretching owing to vertical acceleration.

This same mechanism may also contribute to reduction in whirl vorticity (Snegirev et al. 2004) high up in the vortex where the vertical velocity decreases with height. This could occur when the core's buoyancy is reduced from ambient air entrainment or encountering a stable atmospheric lapse rate aloft. The vertical deceleration would reduce the vorticity.

Increased combustion rates—

A number of researchers have noted significant increases in burning rates of laboratory fire whirled. In all of these studies, the burning rate is defined as the mass loss rate of the fuel source (solid or liquid). Byram and Martin (1962) found a three-fold increase in alcohol burning rate when a whirl formed. Emmons and Ying (1967) found that the burning rate of their acetone pool fires was a function of the externally imposed circulation, with increases of up to seven times the nonwhirl conditions. Martin et al. (1976) measured 1.4 to 4.2 times faster burning rates in fires fueled by cross-piled wood sticks of varying sizes.

The increased burning rate is likely due to increased heat transfer and mixing near the solid or liquid fuel. The question of which mechanism of heat transfer (convection or radiation) is causing the increased burning rates has been examined by several researchers (Chigier et al. 1970, Chuah et al. 2009, Snegirev et al. 2004). Most have speculated that increased convective heat transfer owing to high levels of turbulence near the ground surface and fuel causes the increased burning rates (Chigier et al. (1970, Snegirev et al. 2004). Snegirev et al. (2004) used a computational fluid dynamics model that included a Monte Carlo radiation solver to show that radiation actually decreased when a whirl formed in their study. This was attributed to changes in flame shape, and suggests that radiative heat transfer is

not the cause of increased burning rates in fire whirls. These authors propose that the flow rotation intensifies the entrainment of air into the fuel-rich region near the ground and fuel surface, which causes increased mixing in this area resulting in higher gas temperatures and reaction rates. Chigier et al. (1970) used an isothermal laboratory experiment to show that increased mixing does occur. Their experiment used a suction tube to produce the needed vortex stretching. The isothermal nature of the experiment allowed easy measurement of velocity, including turbulence. They found that turbulence intensities over the first four diameters vertically were much higher than the nonrotating case. Above this height, turbulence intensities reduced to less than the nonrotating case as expected. Chuah et al. (2009) used a scaling analysis and measurements in small experimental fire whirls over pool fires to develop an analytical model of fire whirls, including a heat-feedback mechanism to the pool fire. They found that the average rate of heat transfer from the flame to the fuel surface was a function of the vortex core radius. A smaller radius provided more heat to the fuel surface.

Scaling fire whirls—

Much of what is known about fire whirls comes from small-scale laboratory experiments. Full-scale experiments are usually not practical because of safety concerns, economic aspects, and difficulties of controlling boundary conditions (Emori and Saito 1982). Because of this, scaling laws are very important to consider when attempting to apply information gained from small-scale experiments to full-scale fire whirls. Several authors have examined scaling related to fire whirls.

One of the first investigations of scaling laws related to fire whirls was Emmons and Ying (1967). They suggested that Froude and Rossby numbers were important parameters for understanding their laboratory whirls. Another investigation was that of Emori and Saito (1982). They used a scale model in a wind tunnel to recreate a firefighter entrapment that occurred. The scaling analysis concentrated on fluid flow and buoyancy from the fire, which was simulated in the scale model using electrically heated wires. A modified

Froude number was considered important to proper scaling. In the experiment, they found that a fire whirl occurred on the lee side of a mountain at the location where the firefighters were injured. They also found that the whirl only formed when the ambient crossflow wind was within a certain speed range. Wind above or below this range did not produce a fire whirl.

Soma and Saito (1988, 1991) classified whirls into three different types according to causal factors and behavior and investigated each type using scaling analysis and experiments. Their scaling analysis determined that scaled experiments should be performed with wind velocities and heat generation rates proportional to the square root of the fire widths or one-fourth power of the fire area. They were able to produce fire whirls in their experiments that qualitatively matched the full-scale events. Length scale ratios between the experiments and full-scale whirls were 1/235, 1/2500, and 1/4837. They also found that there was a range of crossflow windspeeds where whirls would form, but above or below this speed, whirls did not form.

Grishin et al. (2004) examined fire whirls using laboratory-generated whirls and found that Grashof and Froude numbers could be used for scaling. They concluded that fire whirl characteristics are determined by the heat-flux density, lift force, and angular momentum of the external vortex flow. Grishin et al. (2005) used a Rossby number derived in a semiempirical way to determine the critical values under which a fire whirl would form in their laboratory experiments. They stated that the rotation velocity of a fire whirl decreases as its radius increases and increases as its height increases. Akhmetov et al. (2007) also used a Froude number for scaling and found that rotational velocity increased as whirl height increased. They mentioned that other similarity criteria based on Grashof number or Reynolds number will vary by many orders of magnitude for vortices of different scale.

To the authors' knowledge, the only discussion of the horizontal movement of fire whirls is given by Grishin (2007) despite its importance to firefighter safety. The paper uses a theoretical basis to analyse how fire whirls move owing to interaction with other fire whirls. In particular, two

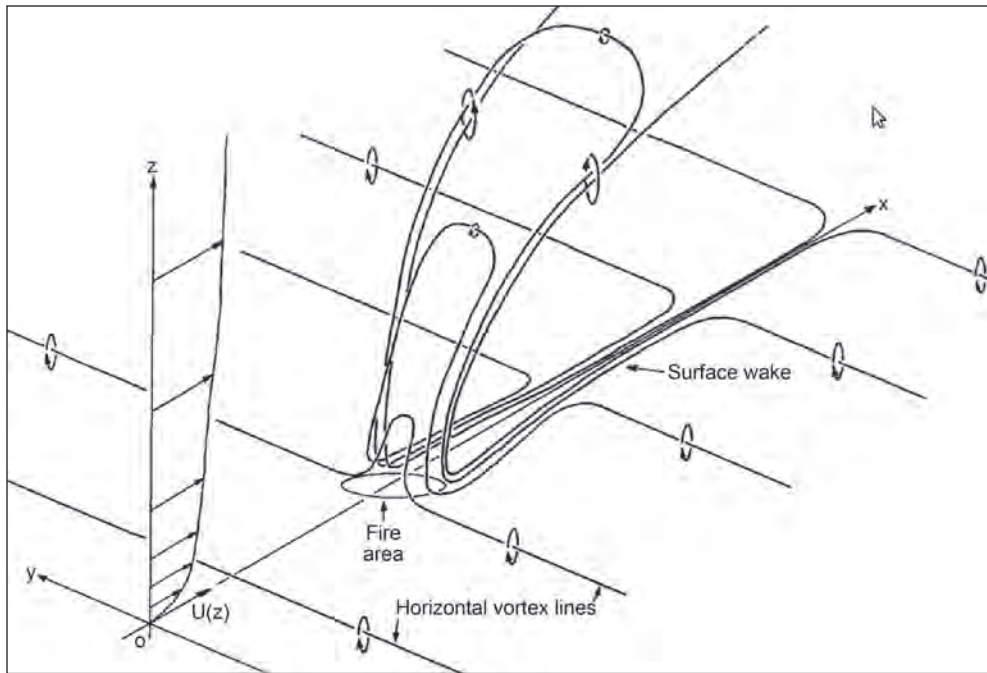

Figure 8-3—A schematic showing how shear generated horizontal vorticity present in the atmosphere near the ground can be reoriented to the vertical by a fire (from Church et al. 1980).

counter-rotating fire whirls with equal intensity in proximity are examined and found to move in the same direction with the same velocity. This could be important when counter-rotating vortices appear on the lee side of a fire plume (Church et al. 1980, Cunningham et al. 2005), which may be fairly common in wildland fires in a crossflow wind.

Kuwana et al. (2007, 2008) examined several experimental and full-scale whirls under crossflow conditions and concluded that a critical crossflow wind velocity exists where fire whirls are most likely to occur. This critical velocity was found to be proportional to the vertical buoyant velocity, which depends on the burning rate and length scale of the burning area.

Vorticity sources—

In the wildland fire context, it appears there are many possible sources of ambient vorticity that could contribute to fire whirls. Morton (1966) discussed some of these sources. One important source may be the shear layer that develops when ambient wind flows over the ground surface, producing horizontally oriented vorticity. This type of vorticity

generation corresponds to the fourth term on the right-hand side of equation (3). As shown in figure 8-3, this horizontal vorticity can then be reoriented, or tilted, by the fire's buoyant flow into the vertical (Church et al. 1980, Cunningham et al. 2005, Jenkins et al. 2001) and may be a major contributor to many fire whirls. Similarly, it is likely the indrafting to a buoyant plume develops a shear layer near the ground that also generates horizontally oriented vorticity that can also be tilted to the vertical. This source of vorticity could be present even in zero ambient wind situations. Complex terrain can also generate vorticity through channeling and shear of ambient and fire-induced winds (Pirsko et al. 1965). Turbulent wake regions behind terrain features such as hills and mountains are thought to produce favorable vorticity for fire whirls (Countryman 1964, 1971; Goens 1978; Graham 1957). Another source of ambient vorticity for some whirls may be vorticity present along frontal boundaries (Billing and Rawson 1982, Umscheid et al. 2006). This may be similar to the meteorological setting for many nonmesocyclone tornadoes (Umscheid et al. 2006).

Another possible source of vorticity in fire whirls is the baroclinic term in equation (3). At this time, it is unclear how important this source of vorticity is to fire whirls. McDonough and Loh (2003) provided an initial examination using numerical modeling. They mainly examined grid resolution requirements and are not able to make any strong conclusions about the significance of baroclinically generated vorticity, other than that it warrants further study.

Fire Whirls in the Real World: Common Features

Many factors influence the development of fire whirls on wildland fires. These factors interact in complex ways, and firefighters will likely not ever have very accurate predictive tools to foresee whirl formation, especially in a timely manner to make real time decisions. For now, the hope is to identify situations that are more likely to form whirls. The following are some likely scenarios where fire whirls have been known to form. It is probable that some of these types of fire whirl scenarios could be combined to possibly make whirl formation more likely or more intense.

Whirl shedding on the lee side of a plume—

This type of whirl forms when a plume is subjected to a crossflow wind. The whirl forms on the lee wind side of the plume. It separates from the plume and advects in the downwind direction. Sometimes multiple whirls of opposite rotating direction shed periodically, similar in appearance to Von Karman vortex shedding behind an obstruction in a flow. Often, as the whirl moves away from the fire, it contains no flaming combustion. Wind in the whirl can be strong enough to cause damage to trees, structures, vehicles, etc., and the whirl may stay intact for several minutes and travel for distances of possibly 2 km. Its ability to stay intact even though most of its vortex stretching mechanism (buoyancy) is lost is probably due to the strong reduction in turbulent diffusion of the core. Examples of this type of whirl have been reported by many authors (Church et al. 1980; Dessens 1962; Hissong 1926; Pirsko et al. 1965; Soma and Saito 1988, 1991) and video and images of others are on file at the U.S. Forest Service's Missoula Fire Sciences Laboratory.

A critical crossflow wind velocity is likely very important to this type of fire whirl, as discussed in "Scaling fire whirls." Cunningham et al. (2005) were able to simulate this type of whirl and hypothesized that the main source of vorticity comes from the tilting of horizontally oriented, shear-generated vorticity in the ambient crossflow. The significance of other sources of vorticity is currently unknown. Others (Fric and Roshko 1994, McMahon et al. 1971, Moussa et al. 1977) have shown that the same shedding whirls are present in an isothermal vertical jet in crossflow, although in these experiments, the whirl formation may also be influenced by the jet shear layer.

L-Shaped heat source in crossflow—

Soma and Saito (1988, 1991) first investigated this type of fire whirl as an explanation for a historical and catastrophic fire whirl that occurred in 1923 in Tokyo. Unlike the shedding whirl, this whirl seems to be mostly stationary. It occurs when a roughly L-shaped heat source is subjected to a crossflow wind as shown in figure 8-4. The whirl forms in the inside bend of the L-shaped heat source. As in the shedding whirl, a critical crossflow windspeed is thought to be important (Soma and Saito 1988, 1991). If the wind is above or below this speed, whirls are less likely to form. This type of whirl is probably very much related to the shedding whirl type, including the important vorticity source from the ambient shear flow.

Vorticity associated with cold fronts—

This type of whirl forms when ambient vertical vorticity from cold fronts interacts with a fire plume. Billing and Rawson (1982) and Umscheid et al. (2006) discussed cases where this type of whirl formed over flat terrain. The key feature of these two examples is that they occurred almost exactly when a cold front passed over the fire area. Umscheid et al. (2006) discussed the associated ambient vertical vorticity present along a cold front boundary and identified some similarities between this type of fire whirl and the formation mechanisms of nonmesocyclone tornadoes. It is currently unclear why fire whirls form under

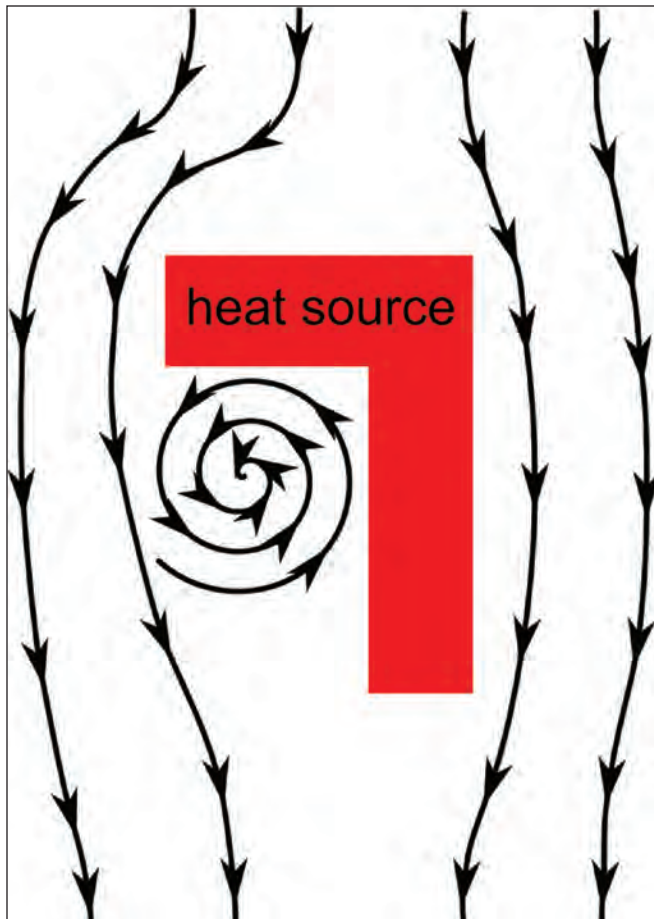

Figure 8-4—Schematic of fire whirl formation for an L-shaped heat source in a crossflow wind. View is from above.

some cold front passage conditions, but not others. Perhaps non-mesocyclone tornado genesis research can help identify why these whirls form.

Multiple interacting plumes—

This type of fire whirl occurs from the interaction of multiple plumes with no ambient crossflow wind. Entrainment into each plume is affected by the nearby plumes, and under the correct configuration and buoyant plume strengths, a whirl can form. Figure 8-5 shows a schematic of how five fires could be oriented to cause a fire whirl. Lee and Otto (1975) observed whirl formation owing to plume interaction in their experiment using two asymmetric-shaped burning wood piles. Zhou and Wu (2007) examined the multiple interacting plume whirl in more detail using experimental fires,

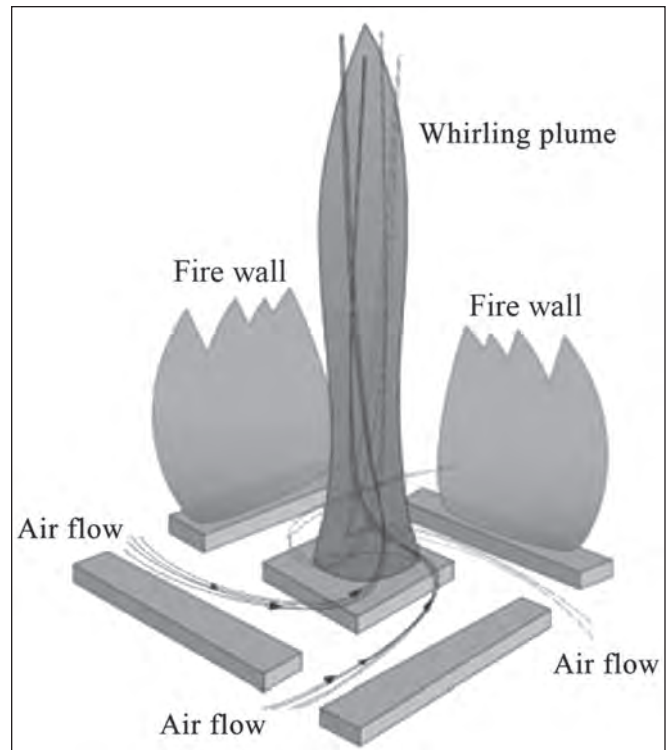

Figure 8-5—Schematic showing one heat source configuration that can cause a multiple interacting plume type fire whirl (from Zhou and Wu 2007).

numerical simulation, and some scaling analysis. They discussed configurations under which whirls would and would not form. They also showed that whirls can form under randomly oriented plume locations (figure 8-6). This has implications to wildland fire under mass-ignition-type conditions. Occurrence of fire whirls under such conditions might be very likely, so long as the multiple plumes are drafting a significant amount of air and are properly spaced and organized.

Lee side of a hill or mountain—

These fire whirls occur when a fire plume exists on the lee side of a terrain obstruction such as a hill or mountain. The plume uses vorticity existing in the wake region of the obstruction to form the whirl. Countryman (1971) stated that this is the most favorable situation for generation of fire whirls. During investigations of full-scale mass fires, Countryman (1964) intentionally burned a fire on a lee slope under moderate wind to investigate this type of whirl.

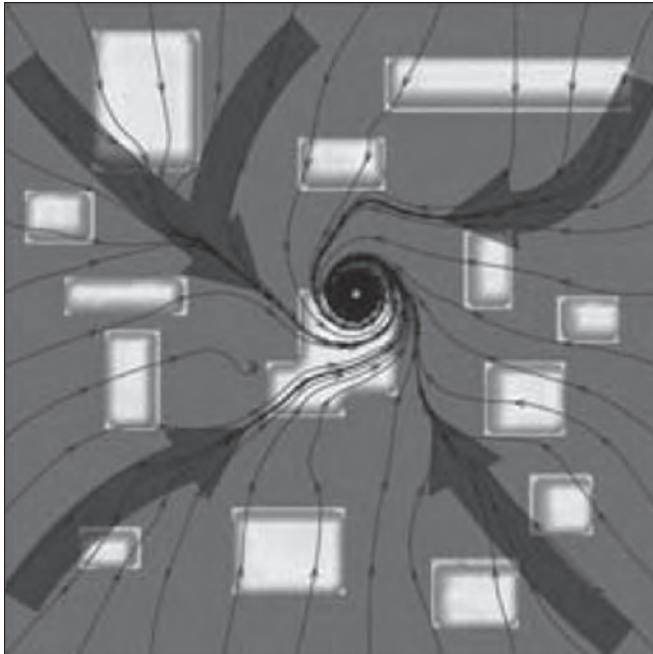

Figure 8-6—Image of a computer simulation showing how randomly oriented heat sources could cause a fire whirl through plume interactions (from Zhou and Wu 2007).

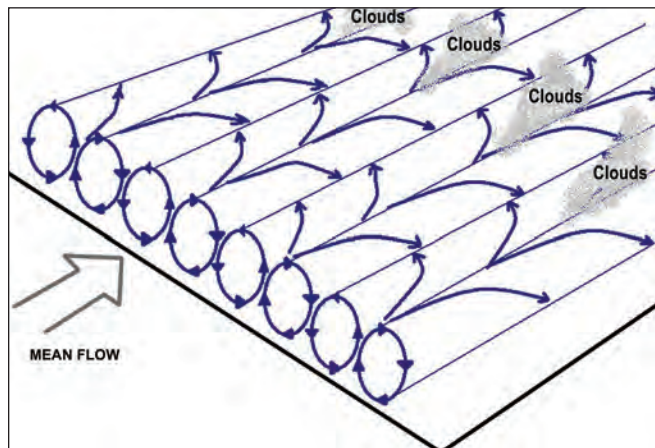

Figure 8-7—Illustration of the role of horizontal vortices in the development of cloud streets (based on Etling and Brown 1993).

Several whirls formed during the burn, with the largest occurring near the end. Pirsko et al. (1965) described a whirl that formed on the lee side of a terrain obstruction and then

shed from the plume in the downwind direction. The whirl caused significant wind damage to several houses, trees, and vehicles. Windspeed at the time was 9.4 m/s with gusts to 13 m/s.

Horizontal Vortices

Horizontal vortices are quite common in the atmosphere and have been extensively studied (see Brown [1980] and Etling and Brown [1993] for reviews). In the absence of wind, when the ground is heated, the warm air near the ground will eventually begin to rise in circulation cells, a process known as Rayleigh-Bernard convection (Fernando and Smith 2001). In the presence of vertical wind shear, these cells begin to transition from disorganized and transient to an organized state of a hexagonal lattice of convective cells. Fair-weather cumulus clouds often mark the tops of updrafts of these cells. As the wind shear increases, the convective cells further organize into horizontal convective rolls that are perpendicular to the mean wind; further increases in the vertical wind shear change the balance between buoyancy-driven vorticity and shear-driven vorticity and leads to the convective rolls being oriented parallel to the mean wind (Küettner 1971). These longitudinal convective rolls are easily seen in satellite images as parallel bands of cumulus clouds known as cloud streets. Figure 8-7 provides an illustration of the structure of these cloud streets. While such horizontal convective rolls are a common feature of the atmosphere in the planetary boundary layer, the presence of a fire adds a complicating factor in the form of a horizontal temperature gradient that can locally alter the convective organization of the boundary layer.

Horizontal vortices associated with wildland fires have received less attention than their vertical counterparts, fire whirls. Haines and Smith (1987) provided descriptions of three distinct types of horizontal vortices observed on wildland fires: the transverse vortex, which is perpendicular to the flow direction, a single longitudinal (flow parallel) vortex and a counter-rotating longitudinal vortex pair.

Transverse Vortices

Transverse vortices are described in Haines and Smith (1987) as a series of vortices “climbing” the upstream side of the convective column under conditions of low ambient windspeeds and intense burning. The mechanism they proposed for the development of such vortices involves the development of buoyancy-forced ring vortices rising through the smoke column. They further hypothesized that only the upwind portion of the ring is clearly visible as turbulent mixing is thought to render the downwind section of the ring less distinct. While transverse vortices on wildland fires have received little attention, extensive literature is available on ring vortices associated with pool fires.

Buoyancy-forced ring vortices are a common feature of fluid flows associated with heat sources ranging in scales from candles to pool fires up to large mass fires; however, they are most clearly visible under conditions of weak mean horizontal flow. For these ring vortices, the vorticity is generated through the baroclinic term from equation (3). Because the thickness of the density layer controls the magnitude of the baroclinically forced vorticity, the strongest vortices have scales similar to that of the flame surface (Cheung and Yeoh 2009). As buoyant forces cause these vortices to rise, a process often referred to as “amalgamation” takes place as the rising vortices merge and grow and manifest themselves in the oscillatory necking and bulging of the fire that results from the Rayleigh-Taylor instability. The same basic process can be observed at the scale of the smoke plume, leading to the development of the transverse vortices described by Haines and Smith (1987). The oscillatory nature of the development of these vortices has been extensively studied for pool fires (Cetegen and Ahmed 1993); however, little has been done at the scale of wildland fire events.

While descriptions of vortex rings are quite common in the literature, little is mentioned about transverse vortices outside of Haines and Smith (1987). These vortices manifest themselves on the upwind side of the plume and add a boiling appearance to the plume. While the vortices themselves

are not a source of erratic fire behavior, their presence is an indicator of a potential increase in the rate of combustion and an associated change in fire behavior.

Longitudinal Vortices

Single longitudinal vortex—

Longitudinal vortices differ from their transverse counterparts in that their axis of rotation is oriented parallel to the mean flow. The first class of longitudinal vortices from Haines and Smith (1987) is the single longitudinal vortex, of which only one case is presented, the Dudley Lake Fire as described by Schaefer (1957). The vortex was oriented in the direction of the mean flow, which was quite strong that day as surface winds were between 16 and 22 m/s. The diameter of the vortex was estimated at 1800 m. Smoke entrained within the vortex delineated the corkscrew-like nature of the vortex and allowed the vortex to be observable 500 km downwind. The scale of this vortex is similar to those of the convective boundary layer rolls responsible for cloud streets and shows strong similarities to roll vortices associated with other crown fires (Haines 1982) with the main exception being that this was only a single vortex.

A possible answer to the question of why only a single vortex was observed may be answered through the numerical modeling work of Heilman and Fast (1992). In this study, a computer model of the atmospheric boundary layer was initialized with multiple heat sources some distance apart to examine how circulations induced by each heat source interacted and how the collection of these flows responded to the introduction of a transverse wind component (wind blowing perpendicular to the axis of the roll vortices). The introduction of the transverse wind component tended to destabilize the longitudinal vortices, and, in some cases, eliminated the upwind vortex entirely. Haines and Smith (1992) similarly found in their wind tunnel studies that a slight transverse component to the flow destabilized the vortex pair, thereby causing the collapse of the downwind (relative to the transverse wind component) vortex, which on a wildland fire would cause the vortex to fall outward across the flank of the fire, providing an additional mechanism for lateral fire spread and a threat to firefighter safety.

On the Dudley Lake Fire, Schaefer (1957) observed at regular intervals, the outward/downward moving segments of the vortex would mark lateral surges in the fire growth, indicating the possible presence of some slight shifts in the wind that may have inhibited the presence of the other vortex.

This vortex type differs from the other two types described in Haines and Smith (1987) in that the fire is not necessarily an integral forcing term in the development of the vortex. Conditions in the atmosphere may already favor the development of the convective rolls, and the fire may simply act to enhance the vortex through additional thermal instability. While the transverse vortices are most pronounced at low windspeeds, the Dudley Lake vortex was, accompanied by surface winds of 16 to 22 m/s (the mean windspeed for the 12 crown fire cases in Haines 1982 was 5.5 m/s).

Counter-rotating, longitudinal vortex pair—

Of the three types of horizontal vortices described by Haines and Smith (1987), the counter-rotating, longitudinal vortex pair, is the best documented, although early work (Scorer 1968, Turner 1960) focused on vortex pairs associated with smokestack emissions rather than wildland fires. The key feature of this vortex type is the paired nature of the vortices rotating in opposite directions. These vortices often occur along the flanks of the fire and can also be observed in the main plume at the head of the fire—this is often referred to as a bifurcating smoke column. Figure 8-8 shows a numerical simulation of a bifurcated smoke plume as viewed from behind the fire. Cunningham et al. (2005) showed that the degree to which the smoke plume splits is related to the depth of the surface shear layer.

The New Miner Fire in central Wisconsin in 1976 is one example of a bifurcated smoke column provided by Haines and Smith (1987). This fire burned under very low relative humidity conditions for the region (minimum of 23 percent) with light winds averaging around 2 m/s. The bifurcated column consisted of a pair of vortices approximately 30 m in diameter, which rotated fairly slowly compared to other atmospheric whirls like tornadoes. These columns would intermittently collapse and spill over the fire’s flanks, bringing hot gases and embers into contact with unburned

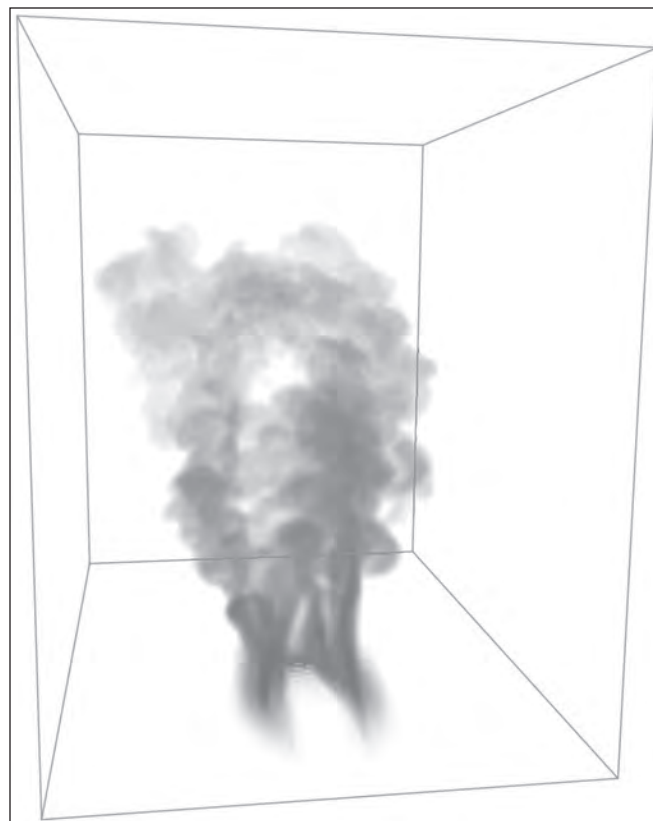

Figure 8-8—Bifurcated smoke plume from a computer simulation. View is from upwind of the fire (from Cunningham et al. 2005).

fuels and providing for rapid lateral spread. Obviously, such behavior is a threat to fire crews that often focus their suppression efforts along the flanks of the fire. A key difference between these vortex pairs and the single vortex is the scale: the bifurcated columns were approximately 30 m in diameter while the vortex on the Dudley Lake Fire was over a kilometer.

As part of a 1979 study conducted at the Centre de Recherches Atmosphériques Henri Dessens in France, Church et al. (1980) studied the vortices produced by the Météotron, an array of 105 oil burners with a total heat output of 1,000 MW. Three types of vortices were observed: (1) a columnar vortex that had the entire smoke column rotating, (2) small dust-devil like vortices just downwind of the burner array, and (3) a large, counter-rotating vortex pair within the plume that started as vertical vortices at the burn site, but became horizontal and oriented parallel to the wind as the plume rose and moved downwind. The first two

vortex types are vertical vortices as described in the section on fire whirls.

The third type resembles the bifurcating column described for the New Miner Fire. At a height of 40 to 50 m, the smoke column of the Météotron experiment bifurcated into a pair of counter-rotating vortices with initial diameters of 30 to 60 m (Church et al. 1980). The dominant motion associated with these vortices was rotation about their axis with little noticeable motion along the axis, a stark contrast to the strong axial flow observed in many fire whirls.

The forcing of the counter-rotating vortex pair is complex and has parallels with the forcing of similar vortex pairs by nonbuoyant jets in a crossflow (see Margason 1993 for a review). The split plume develops through the interaction of the ambient vorticity in the flow produced by vertical wind shear with the jet shear layer (or plume shear layer in the case of wildland fires). The presence of buoyancy adds complexity to the forcing of the split plume compared to the nonbuoyant jet. Church et al. (1980) put forth a pair of physical processes capable of describing the development of the bifurcating smoke column. The first process focuses on the reorientation and stretching of the horizontal vorticity in the ambient flow. Initially, the ambient vorticity can be thought of as a collection of horizontal tubes oriented perpendicular to the wind with upward motion along the upwind side of the tube and downward motion along the downwind side. As these vortex tubes encounter the rising air at the fire, the portion of the tube over the fire is lifted, which acts to tilt the vortex tube at the edge of the fire into a vertical orientation, producing a hairpin-like shape. As the lifted portion of the vortex tube continues to rise in the plume, it encounters stronger horizontal winds that transport this portion of the tube downwind faster than the surface parts, stretching the arms of the hairpin vortex. Eventually the combined processes of the lifting and faster downwind transport leads to the majority of the hairpin vortex being oriented horizontal and parallel to the mean flow. This is illustrated in figure 8-3.

The second process proposed by Church et al. (1980) deals with the generation of vorticity through the combined effects of buoyancy and surface drag forces. This process is

actually a variation on the buoyant rings discussed earlier. The variation is the impact of the crossflow on the rising ring vortex. On the upwind edge of the ring, the crossflow enhances entrainment of ambient air on that side of the plume, which decreases the vertical velocity of that part of the plume. This causes the downwind section of the ring to rise faster than the upwind side, tilting some of the vorticity into a vertical orientation. The downwind section also encounters the stronger winds aloft before the upwind side, which leads to a stretching/intensifying of the streamwise sections of the ring. Experiments by Tsang (1970, 1971) supported the viability of this method in generating the counter-rotating vortex pair.

While both physical processes are plausible explanations for the development of the counter-rotating vortex pair, both are not equally supported by the observations. Many of the observed fire plumes exhibited significant near-surface vertical vorticity, which is best supported by the first process, which relies upon the reorientation of ambient vorticity (Cunningham et al. 2005). Wind tunnel studies of the longitudinal vortex pair offer further support for the ambient vorticity process as Smith et al. (1986) found the vorticity in the streamwise vortex pair to agree quite well with the vorticity of the ambient flow as it approached the heat source. This is not to suggest that the buoyancy generated from the fire has no impact, just that it is not the dominant forcing for the development of the vortex pair.

Numerical modeling studies of the longitudinal vortex pair have largely been two dimensional (Heilman and Fast 1992; Luti 1980, 1981; Porteiro et al. 1999) or quasi three-dimensional (streamwise flow component assumed constant) where the governing equations are solved for a number of planes perpendicular to the streamwise flow (McGratten et al. 1996, Trelles et al. 1999, Zhang and Ghoniem 1993). Cunningham et al. (2005) was the first fully three-dimensional simulation of fire plumes to focus on the development of vortical structures. Their simulations revealed the relationship between the depth of the shear layer, fire intensity, and the behavior of the vortex pair. The basics of this relationship centered around how long it took a buoyant air parcel to traverse the shear layer. Keeping the mean crossflow constant, a deeper shear layer would lead

to a wider split of the smoke column. If the fire intensity is increased, the air parcels travel through the shear layer faster, which leads to a decrease in the width of the plume split. One interesting observation is that for a given fire intensity, the plume rise is not affected by the width of the smoke column's bifurcation, although its horizontal spread and deviation from a Gaussian distribution are strongly affected.

Another aspect of the counter-rotating vortex pair described by the numerical simulations of Cunningham et al. (2005) is the potential for oscillations, with each branch periodically exhibiting dominance. These oscillations were linked with localized regions of vertical vorticity of alternating signs being shed from either side of the plume in a manner similar to wake vortices observed for fluid flowing around a cylinder. While these results were limited to a narrow range of flow parameters, these simulations indicate that the counter-rotating vortex pair are not necessarily stable. Wind tunnel studies using a heated wire to mimic the flank of a crown fire have shown that perturbations in the flow component perpendicular to the mean flow can cause the vortex pair to collapse (Haines and Smith 1992). These flow perturbations could be caused by upstream topographic features, possibly groups of trees, or even natural shifts in the ambient wind.

In the previous discussion, the wind profile reflected typical conditions where windspeed increased with height. Byram (1954) noted that a number of major fire runs occurred when the windspeed decreased with height near the surface, a conditions known as an adverse wind profile. Clark et al. (1996) examined the potential impact of an adverse wind profile on fire spread through the use of a three-dimensional coupled fire-atmosphere model. In their simulations, a counter-rotating vortex formed through the reorientation of the ambient boundary layer vorticity as described above; however, this time the rotation was in the opposite direction (see fig. 2 of Clark et al. 1996), which leads to narrow regions of hot, high-speed air shooting out of the fire front. This dynamic fingering occurred at scales of the order of tens of meters and has the potential to augment fire spread.

Tree Crown Streets

Some fires exhibit complex patterns of alternating strips of burned and unburned fuel, often referred to as tree crown streets. One possible explanation for the development of tree crown streets involves horizontal roll vortices (Haines 1982). It is hypothesized that on one side of the vortex, descending air cools the fuels and causes surface winds to diverge, thus inhibiting crown fire spread. On the other side of the vortex, upward motion is enhancing the convective column owing to the associated surface wind convergence, which can, in turn, enhance a spreading crown fire. Tree crown streets are cited as evidence for the presence of horizontal roll vortices on the Mack Lake Fire (Simard et al. 1983). Wade and Ward (1973) observed complex patterns of intermittent strips of unburned fuel in the Air Force Bomb Range Fire and suggested some potential hypotheses for these patterns including brief fluctuations of windspeed or direction, or pulsations of long-range spotting linked to an erratic convective column. While often considered a fingerprint for the presence of horizontal roll vortices, the exact cause of tree crown streets is not known.

Summary

Vorticity describes the degree of rotation in the atmosphere about some axis. Two factors that induce rotation in the atmosphere are wind shear and sharp horizontal gradients in temperature. Once one of these factors has generated vorticity, that vorticity can be transported by the mean wind to other locations, reoriented from one axis to another (a horizontal vortex can be tilted to become a vertical vortex), or enhanced by flow convergence, which stretches the vortex. The atmosphere is rarely completely devoid of vorticity. If the wind is blowing at all, vorticity is produced near the ground by surface drag. Terrain features provide flow obstacles whose drag produces wind shear and thus generates vorticity. Different ground surfaces heat at different rates, which also generates vorticity. Vortices are present across a broad spectrum of spatial scales, continuously transferring energy between scales, mostly from large scales to smaller scales. A fire not only interacts with and modifies this ambient vorticity but also generates additional vorticity.

Table 8-1—Summary of vortices, their causes and potential threats

Phenomenon	Causal factor(s)	Potential danger
Fire whirl formation on the lee side of a plume	Shear-generated vorticity near the ground is concentrated and reoriented to the vertical on the lee side of the plume.	Increased energy release rate, spread rate, and spotting. The whirl could travel downwind from the fire and overtake firefighters.
Fire whirl formation near an L-shaped fire in a crossflow wind	Shear-generated vorticity near the ground is concentrated and reoriented to the vertical on the lee side of the L, as shown in figure 8-4.	Increased energy release rate, spread rate, and spotting. The whirl could suddenly form in the “interior” area of L.
Fire whirl formation near a cold front	Vorticity along the frontal boundary is concentrated into a fire whirl.	Increased energy release rate, spread rate, and spotting.
Fire whirl formation due to multiple interacting fire plumes	The indrafting and blocking effects of multiple interacting fire plumes concentrate vorticity that was likely shear-generated near the ground.	Increased energy release rate, spread rate, and spotting. Whirl could build into a fire storm.
Fire whirl formation on the lee side of a hill/mountain	Vorticity associated with the wake region of a terrain obstruction such as a hill or mountain is concentrated into a fire whirl.	Increased energy release rate, spread rate, and spotting. The fire could quickly switch from a sheltered, backing fire with low fire behavior to more extreme fire behavior. The whirl could travel downwind from the fire and overtake firefighters.
Transverse vortex on the upwind side of a smoke column	Horizontal vorticity is produced through buoyancy.	Not a source of erratic fire behavior, but rather an indicator of a potential increase in the rate of combustion and an associated change in fire behavior.
Single longitudinal vortex	Unstable atmosphere and strong winds generate horizontal vortices with axis parallel to the wind direction. Vortex formation is not tied to the fire.	Slight variations in wind direction can destabilize the vortex, causing the vortex to fall outward across the flank of the fire, providing a mechanism for lateral bursts in fire spread.
Counter-rotating longitudinal vortex pair	Transverse ambient vorticity from surface wind shear is altered by the fire as it is tilted into the vertical and reoriented to the longitudinal direction. Evident as a bifurcated smoke plume.	Can produce concentrated wind bursts at the head of the fire that lead to strong fingering of the fire front. The vortices are not always stable as variations in wind direction can cause one of the vortices to collapse and bring hot gases and fire brands into contact with the unburned fuel.

For convenience, we split our discussion of wildland fire vortices into vertical and horizontal vortices. Vertical vortices, often referred to as fire whirls, are the most dramatic and frequently described type of vortex. Fire whirls, especially the larger ones, represent a considerable safety hazard to firefighters as these vortices can result in sudden increases in fire intensity, spotting, erratic spread rate and direction, and damaging winds. Most often, the source of vorticity for a fire whirl is not the fire itself; rather, the vorticity is present in the ambient atmosphere. This ambient vorticity may be generated by wind shear, vortex shedding in the wake of a plume or topographic obstruction, or an approaching cold front. The fire plays a much more important role in modifying the ambient vorticity field by tilting horizontal vortices toward the vertical, and increasing the vorticity magnitude through the stretching term as surface flow converges at the fire to feed the strong updraft.

Similarly, two of the three horizontal vortex types described by Haines and Smith (1987) rely upon ambient vorticity. The counter-rotating vortex pair builds upon the tilting and stretching vortex modifications that enable a fire to transform horizontal vorticity generated by wind shear into a vertically oriented fire whirl. The key addition is stronger winds above the surface that sweep the upper part of the hairpin vortex described in figure 8-3 downwind, bending the vortices back toward a horizontal orientation. For the single longitudinal vortex described for the Dudley Lake Fire, the fire is interacting with vorticity on a much larger scale, a boundary layer role whose depth can occupy the entire mixed layer. Again the fire's role is one of modifying the vortex, which can in turn modify the fire environment by changing windflow patterns near the fire and creating a positive feedback loop leading to fire intensification.

Vortices are common features of the atmosphere occurring across a broad range of spatial scales. Our understanding of how wildland fires interact with this broad spectrum of atmospheric vortices is still very much in development. Table 8-1 summarizes the various vortices described in the text along with their causes and potential threats. While the occurrence of these vortices is currently impossible to predict with precision, having a basic

understanding of the importance of ambient atmospheric vorticity for vortex development provides some guidance on situations that require awareness. Examine surrounding topography relative to the expected wind direction, noting features that may block or channel the flow. Wind profiles when available can provide information on wind shear as can watching direction/speed of cloud movements and their organization (are the clouds forming in lines?). Observe the behavior of the fire and smoke plume. Vortices are almost always present along the flaming front at some scale. Watch for vortices that grow or persist. Watch the smoke plume for signs of rotation or splitting. While this information is not sufficient for predicting the occurrence of intense vortices on wildland fires, it can help identify potentially hazardous conditions.

Literature Cited

- Akhmetov, D.G.; Gavrilov, N.V.; Nikulin, V.V. 2007.** Flow structure in a fire tornado-like vortex. *Doklady Physics*. 52: 592–595.
- Battaglia, F.; McGrattan, K.B.; Rehm, R.G.; Baum, H.R. 2000.** Simulating fire whirls. *Combustion Theory Modeling*. 4: 123–138.
- Beer, J.M.; Chigier, N.A.; Davies, T.W.; Bassindale, K. 1971.** Laminarization of turbulent flames in rotating environments. *Combustion and Flame*. 16(1): 39–45.
- Billing, P.; Rawson, R. 1982.** A fire tornado in the sunset country. Report 11. Victoria, BC: Forests Commission. Fire Research Branch.
- Brown, R.A. 1980.** Longitudinal instabilities and secondary flows in the planetary boundary layer: a review. *Reviews of Geophysics and Space Physics*. 18: 683–697.
- Byram, G.M. 1954.** Atmospheric conditions related to blowup fires. Station Paper No. 35. Asheville, NC: U.S. Department of Agriculture, Forest Service, Southeastern Forest Experiment Station.

- Byram, G.M.; Martin, R.E. 1962.** Fire whirlwinds in the laboratory. *Fire Control Notes*. 33(1): 13–17.
- Cetegen, B.G.; Ahmed, T.A. 1993.** Experiments on the periodic instability of buoyant plumes and pool fires. *Combustion and Flame*. 93: 157–184.
- Cheung, S.C.P.; Yeoh, G.H. 2009.** A fully-coupled simulation of the vortical structures in a large-buoyant pool fire. *International Journal of Thermal Sciences*. 48: 2187–2202.
- Chigier, N.A.; Beer, J.M.; Grecov, D.; Bassindale, K. 1970.** Jet flames in rotating flow fields. *Combustion and Flame*. 14(2): 171–180.
- Chuah, K.H.; Kushida, G. 2007.** The prediction of flame heights and flame shapes of small fire whirls. *Proceedings of the Combustion Institute*. 31: 2599–2606.
- Chuah, K.H.; Kuwana, K.; Saito, K. 2009.** Modeling a fire whirl generated over a 5-cm-diameter methanol pool fire. *Combustion and Flame*. 156: 1828–833.
- Church, C.R.; Snow, J.T.; Dessens, J. 1980.** Intense atmospheric vortices associated with a 1000 MW fire. *Bulletin of the American Meteorological Society*. 61(7): 682–694.
- Clark, T.L.; Jenkins, M.A.; Coen, J.L.; Packham, D.R. 1996.** A coupled atmosphere-fire model: role of the convective Froude number and dynamic fingering at the fireline. *International Journal of Wildland Fire*. 6(4): 177–190.
- Clements, C.B.; Zhong, S.; Bian, X.; Heilman, W.E.; Byun, D.W. 2008.** First observations of turbulence generated by grass fires. *Journal of Geophysical Research*: 113. D22102. doi: 10.1029/2008JD010014.
- Countryman, C.M. 1964.** Mass fires and fire behavior. Res. Pap. PSW-19. Berkeley, CA: U.S. Department of Agriculture, Forest Service, Pacific Southwest Forest and Range Experiment Station. 53 p.
- Countryman, C.M. 1971.** Fire whirls: why, when, and where. Res. Note PSW-216. Berkeley, CA: U.S. Department of Agriculture, Forest Service, Pacific Southwest Forest and Range Experiment Station. 6 p.
- Cunningham, P.; Goodrick, S.L.; Hussaini, M.Y.; Lin, R.R. 2005.** Coherent vortical structures in numerical simulations of buoyant plumes from wildland fires. *International Journal of Wildland Fire*. 14: 61–75.
- Dessens, J. 1962.** Man-made tornadoes. *Nature*. 193(4810): 13–14.
- Ebert, C.H.V. 1963.** Hamburg's fire storm weather. *National Fire Protection Association Quarterly*. 56(3): 253–260.
- Emmons, H.W.; Ying, S.J. 1967.** The fire whirl. *Proceedings of the 11th international symposium on combustion*. Pittsburgh, PA: Combustion Institute: 475–488.
- Emori, R.I.; Saito, K. 1982.** Model experiment of hazardous forest fire whirl. *Fire Technology*. 18(4): 319–327.
- Etling, D.; Brown, R.A. 1993.** Roll vortices in the planetary boundary layer: a review. *Boundary-Layer Meteorology*. 65: 215–248.
- Fernando, H.J.S.; Smith, D.C.I. 2001.** Vortex structures in geophysical convection. *European Journal of Mechanics–B/Fluids*. 20(4): 437–470.
- Fric, T.; Roshko, A. 1994.** Vortical structure in the wake of a transverse jet. *Journal of Fluid Mechanics*. 279: 1–47.
- Gess, D.; Lutz, W. 2002.** Firestorm at Peshtigo: a town, its people and the deadliest fire in American history. New York: Henry Holt Publishing. 320 p.
- Goens, D.W. 1978.** Fire whirls. Tech. Memo. NWS WR-129. Missoula, MT: National Oceanic and Atmospheric Administration.
- Graham, H.E. 1952.** A firewhirl of tornadic violence. *Fire Control Notes*. 13(2): 22–24.

- Graham, H.E. 1955.** Fire whirlwinds. *Bulletin of the American Meteorological Society.* 36(3): 99–103.
- Graham, H.E. 1957.** Fire-whirlwind formation as favored by topography and upper winds. *Fire Control Notes.* 18(1): 20–24.
- Grishin, A.M. 2007.** Effect of the interaction between fire tornadoes on their propagation. *Doklady Physics.* 52(10): 521–522.
- Grishin, A.M.; Golovanov, A.N.; Kolesnikov, A.A.; Strokatov, A.A.; Tsyvk, R.S. 2005.** Experimental study of thermal and fire tornadoes. *Doklady Physics.* 50: 66–68.
- Grishin, A.M.; Golovanov, A.N.; Sukov, Y.V. 2004.** Physical modeling of firestorms. *Doklady Physics.* 49: 191–193.
- Haines, D.A. 1982.** Horizontal roll vortices and crown fires. *Journal of Applied Meteorology.* 2: 751–762.
- Haines, D.A.; Smith, M.C. 1987.** Three types of horizontal vortices observed in wildland mass and crown fires. *Journal of Climate and Applied Meteorology.* 26: 1624–1637.
- Haines, D.A.; Smith, M.C. 1992.** Simulation of the collapse of bent-over vortex pairs observed in wildland fires. *Forest Science.* 38: 68–79.
- Haines, D.A.; Updike, G.H. 1971.** Fire whirlwind formation over flat terrain. Res. Pap. NC-71. St. Paul, MN: U.S. Department of Agriculture, Forest Service, North Central Forest Experiment Station. 13 p.
- Heilman, W.E.; Fast, J.D. 1992.** Simulations of horizontal roll vortex development above lines of extreme surface heating. *International Journal of Wildland Fire.* 2: 55–68.
- Hissong, J. 1926.** Whirlwinds at oil-tank fire, San Luis Obispo, California. *Monthly Weather Review.* 54: 161–163.
- Jenkins, M.A.; Clark, T.; Coen, J. 2001.** Coupling atmospheric and fire models. In: Johnson, E.A.; Miyanishi, K., eds. *Forest fires: behavior and ecological effects.* San Diego, CA: Academic Press. 598 p.
- King, A.R. 1964.** Characteristics of a fire-induced tornado. *Australian Meteorological Magazine.* 44: 1–9.
- Komurasaki, S.; Kawamura, T.; Kuwahara, K. 1999.** Formation of a fire tornado and its breakdown. *Theoretical and Applied Mechanics.* 48: 331–338.
- Küettner, J.P. 1971.** Cloud bands in the atmosphere. *Tellus.* 23: 404–425.
- Kuwana, K.; Sekimoto, K.; Saito, K.; Williams, F.A. 2008.** Scaling fire whirls. *Fire Safety Journal.* 43: 252–257.
- Kuwana, K.; Sekimoto, K.; Saito, K.; Williams, F.A.; Hayashi, Y.; Masuda, H. 2007.** Can we predict the occurrence of extreme fire whirls? *American Institute of Aeronautics and Astronautics Journal.* 45(1): 16–19.
- Lee, S.L.; Otto, F.W. 1975.** Gross vortex activities in a simple simulated urban fire. *Symposium (International) on Combustion.* 15(1): 157–62.
- Luti, F.M. 1980.** Transient flow development due to a strong heat-source in the atmosphere. I. Uniform temperature source. *Combustion Science and Technology.* 23: 163–175.
- Luti, F.M. 1981.** Some characteristics of a two-dimensional starting mass fire with cross flow. *Combustion Science and Technology.* 26: 25–33.
- Margason, R.J. 1993.** Fifty years of jet in crossflow research. In: *Proceedings of the AGARD symposium on computational and experimental assessment of jets in crossflow.* Winchester, United Kingdom: Advisory Group for Aerospace Research and Development; London.
- Martin, R.E.; Pendleton, D.W.; Burgess, W. 1976.** Effect of fire whirlwind formation on solid fuel burning rates. *Fire Technology.* 12(1): 33–40.
- McDonough, J.M.; Loh, A. 2003.** Simulation of vorticity-buoyancy interactions in fire-whirl-like phenomena. In: *Proceedings, American Society of Mechanical Engineers heat transfer summer conference.* American Society of Mechanical Engineers: 195–201.

- McGratten, K.B.; Baum, H.R.; Rehm, R.G. 1996.** Numerical simulation of smoke plumes from large oil fires. *Atmospheric Environment*. 30: 4125–4136.
- McMahon, H.; Hester, D.; Palfery, J.G. 1971.** Vortex shedding from a turbulent jet in a cross-wind. *Journal of Fluid Mechanics*. 48: 73–80.
- McRae, D.J.; Flannigan, M.D. 1990.** Development of large vortices on prescribed fires. *Canadian Journal of Forest Research*. 20: 1878–1887.
- Meroney, R.N. 2003a.** Fire whirls and building aerodynamics. In: Proceedings of the 11th international conference on wind engineering. <http://www.engr.colostate.edu/~meroney/projects/MERFWB.pdf>. 16 May 2011.
- Meroney, R.N. 2003.** Fire whirls, fire tornados, and fire storms: physical and numerical modeling. In: Proceedings of PHYSMOD2003: International workshop on physical modeling of flow and dispersion phenomena. <http://www.engr.colostate.edu/~meroney/PapersPDF/CDP03-04-1.pdf>. (16 May 2011).
- Moore, T. 2008.** Indians Fire accident prevention analysis. Vallejo, CA: U.S. Department of Agriculture, Forest Service, Pacific Southwest Region. 113 p.
- Morton, B.R. 1966.** Geophysical vortices. *Progress in Aerospace Sciences*. 7: 145–194.
- Moussa, Z.M.; Trischka, J.W.; Eskinazi, S. 1977.** The near field in the mixing of a round jet with a cross-flow. *Journal of Fluid Mechanics*. 80: 49–90.
- Muraszew, A.; Fedele, J.B.; Kuby, W.C. 1979.** The fire whirl phenomenon. *Combustion and Flame*. 34: 29–45.
- Musham, H.A. 1941.** The Great Chicago Fire. In: Papers in Illinois History and Transactions for the Year 1940. Springfield, IL: Illinois Historical Society: 69–189.
- Pirsko, A.R.; Sergius, L.M.; Hickerson, C.W. 1965.** Causes and behavior of a tornadic fire-whirlwind. Res. Note PSW-61. Berkeley, CA: U.S. Department of Agriculture, Forest Service, Pacific Southwest Forest and Range Experiment Station. 13 p.
- Porteire, B.; Loraud, J.C.; Morvan, D.; Larini, M. 1999.** A numerical study of buoyant flow in cross-flow conditions. *International Journal of Wildland Fire*. 9: 101–108.
- Schaefer, V.J. 1957.** The relationship of jet streams to forest fires. *Journal of Forestry*. 55: 419–425.
- Scorer, R.S. 1968.** Air pollution. Oxford, United Kingdom: Pergamon Press. 151 p.
- Simard, A.J.; Haines, D.A.; Blank, R.W.; Frost, J.S. 1983.** The Mack Lake Fire. Gen. Tech. Rep. NC-83. St. Paul, MN: U.S. Department of Agriculture, Forest Service, North Central Forest Experiment Station. 36 p.
- Smith, M.C.; Haines, D.A.; Main, W.A. 1986.** Some characteristics of longitudinal vortices produced by line-source heating in a low-speed wind tunnel. *International Journal of Heat Mass Transfer*. 29: 59–68.
- Snegirev, A.Y.; Marsden, J.A.; Francis, J.; Makhviladze, G.M. 2004.** Numerical studies and experimental observations of whirling flames. *International Journal of Heat and Mass Transfer*. 47: 2523–2539.
- Soma, S.; Saito, K. 1988.** A study of fire whirl on mass fires using scaling models. In: Proceedings of the first international symposium on scale modeling: Tokyo: The Japan Society of Mechanical Engineers. 353 p.
- Soma, S.; Saito, K. 1991.** Reconstruction of fire whirls using scale models. *Combustion and Flame*. 86: 269–284.
- Trelles, J.; McGrattan, K.B.; Baum, H.R. 1999.** Smoke transport by sheared winds. *Combustion Theory and Modeling*. 3: 323–341.
- Tsang, G. 1970.** Laboratory study of two-dimensional starting plumes. *Atmospheric Environment*. 4: 519–544.
- Tsang, G. 1971.** Laboratory study of line thermals. *Atmospheric Environment*. 5: 445–471.
- Turner, J.S. 1960.** A comparison between buoyant vortex rings and vortex pairs. *Journal of Fluid Mechanics*. 7: 419–433.

Umscheid, M.; Monteverdi, J.; Davies, J. 2006.

Photographs and analysis of an unusually large and long-lived firewhirl, *Severe Storms Meteorology*. 1: 1–13.

U.S. Department of the Interior, Bureau of Land

Management [USDI BLM]. 2001. Preliminary 72 hour briefing on Fish Fire deployment investigation. http://www.wildfirelessons.net/documents/2001_Fish_Crk_72_hr.pdf. (23 March 2010).

U.S. Department of the Interior, Bureau of Land

Management [USDI BLM]. 2006. New York Peak Fire burnover, factual report. http://www.wildfirelessons.net/documents/new_york_peak_factual_report_2006.pdf. (March 23, 2010).

Wade, D.D.; Ward, D.E. 1973. Analysis of the Air Force bomb range fire. Res. Pap. SE-105. Asheville, NC: U.S. Department of Agriculture, Forest Service, Southeastern Forest Experiment Station. 38 p.

Zhang, X.; Ghoniem, A.F. 1993. A computational model for the rise and dispersion of wind-blown, buoyancy-driven plumes. I. Neutrally stratified atmosphere. *Atmospheric Environment*. 15: 2295–2311.

Zhou, R.; Wu, Z.N. 2007. Fire whirls due to surrounding flame sources and the influence of the rotation speed on flame height. *Journal of Fluid Mechanics*. 583: 313–345.

Chapter 9: Crown Fire Dynamics in Conifer Forests

Martin E. Alexander¹ and Miguel G. Cruz²

As for big fires in the early history of the Forest Service, a young ranger made himself famous by answering the big question on an exam, “What would you do to control a crown fire?” with the one-liner, “Get out of the way and pray like hell for rain.” – Norman Maclean (1992)

Introduction

Wildland fire behavior is broadly defined as the manner in which fuel ignites, flame develops, fire spreads and exhibits other related characteristics as determined by the interactions of fire with its environment (Merrill and Alexander 1987). Not surprisingly, wildland fires have been referred to as highly volatile, multidimensional phenomena, not easily observed, monitored, documented, or necessarily explained. Many fire management decisions and actions require fire operations personnel to estimate, as quickly and accurately as possible, how a fire will behave under defined burning conditions. A prognosis of probable fire behavior provides for the safe and effective management or control of free-burning fires, whether of chance or planned origin (Countryman 1972).

Barrows (1951) outlined the basic concepts of predicting or forecasting fire behavior over 65 years ago. The general problem or difficulty with predicting fire behavior simply boils down to the fact that there are numerous, interacting variables involved. Even predicting the most basic fire behavior characteristic—the type of fire (fig. 9-1)—constitutes an immense challenge. As Rothermel (1991a) pointed out, for example, “The onset of crowning is exceedingly complex; wind, slope, humidity, fuel moisture, atmospheric stability, inversions, surface fire intensity, ladder fuels, time of year, amount of exposed fireline, and

frontal passage can all play a role.” Figure 9-2, while a gross oversimplification of the process, illustrates the information flow involved in predicting free-burning fire behavior, and the kinds of application of such knowledge, especially as it relates to crown fires.

In conifer-dominated forest fuel complexes (see “Common and Scientific Names” section), **three broad types** of fire are commonly recognized on the basis of the fuel layer(s) controlling their propagation:

- Ground or subsurface fire,
- Surface fire, and
- Crown fire

Ground or subsurface fires spread very slowly (about 3 cm/h), with no visible flame and sometimes with only the occasional wisp of smoke (Albini 1984, Frandsen 1991, Wein 1981). Heading surface fires can spread with the wind or upslope, and backing surface fires burn into the wind (fig. 9-1A) or downslope. A crown fire is dependent on a surface fire for both its initial emergence and continued existence. Thus, a crown fire advances through both the surface and tree canopy fuel layers with the surface and crown fire phases more or less linked (figs. 9-1B and 9-1C). The term “crowning,” therefore, refers to both the ascension of fire into the crowns of trees and the spread of fire from crown to crown. As Van Wagner (1983) noted, “all large fires contain areas of low as well as high intensity, usually in a complex mosaic depending on vegetation type, topography, wind variations and time of day the fire passed a particular spot” (fig. 9-3).

From the perspective of controlling or managing wildfires or unplanned ignitions, the development and subsequent movement of a crown fire represents a highly significant event as a result of the sudden escalation in the rate of advance and the dramatic increase in flame size and thermal radiation as well as convective activity, including fire-induced vortices, and, in turn, both short- to long-range

¹ **Martin E. Alexander**, Department of Renewable Resources and Alberta School of Forest Science and Management, University of Alberta, Edmonton, Alberta, Canada.

² **Miguel G. Cruz**, CSIRO Land and Water Flagship Ecosystem Sciences, Canberra, Australian Capital Territory, Australia.



Figure 9-1—Variations in fire behavior within the jack pine/black spruce fuel complex found at the International Crown Fire Modeling Experiment study area near Fort Providence, Northwest Territories, Canada: (A) surface fire, (B) passive crown fire, and (C) active crown fire. Photos by M.G. Cruz. For additional photography carried out on an experimental basis, see Alexander and De Groot (1988), Alexander and Lanoville (1989), Stocks and Hartley (1995), and Hirsch et al. (2000).

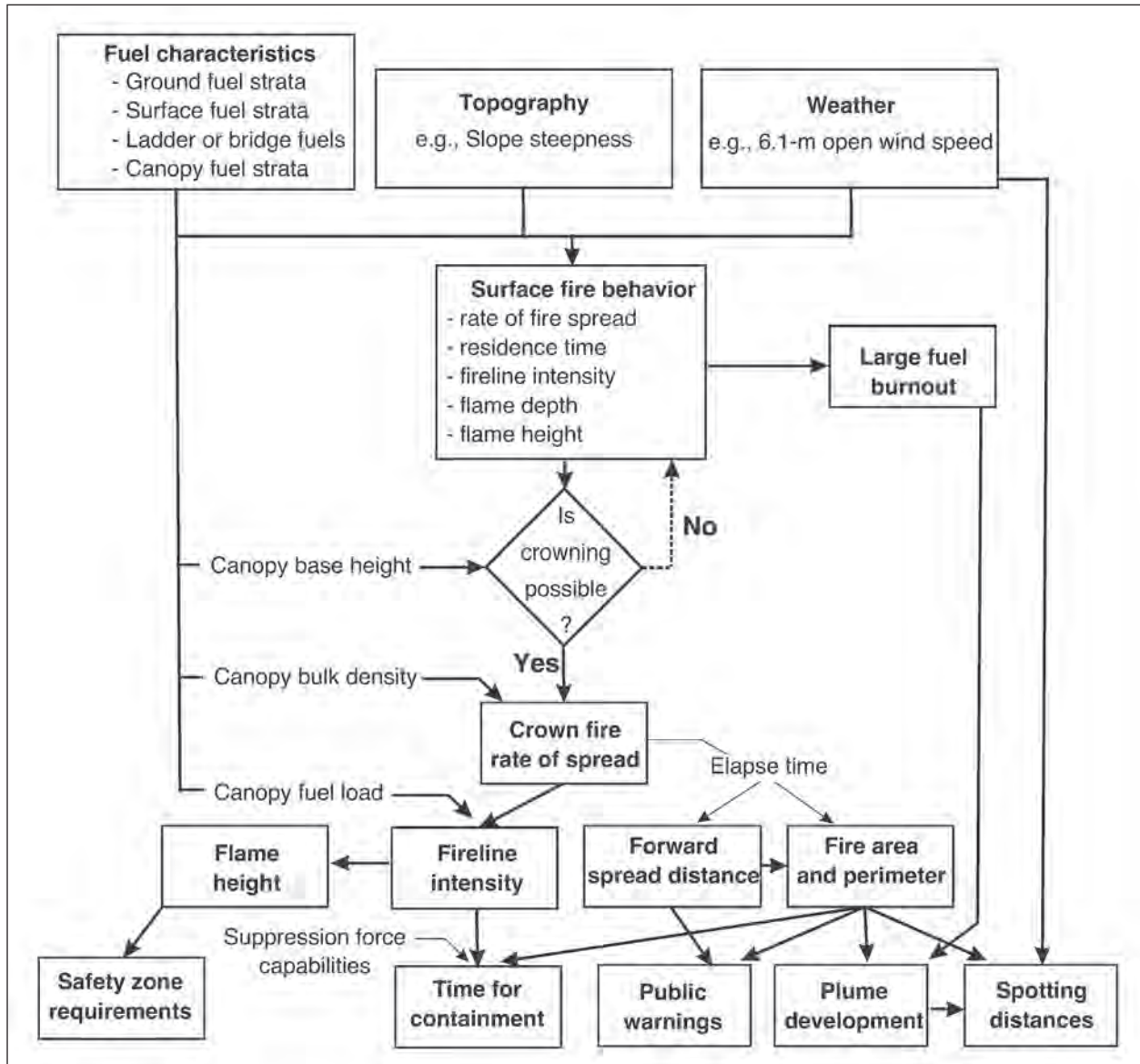

Figure 9-2—Flow chart illustrating the linkages involved in the prediction of crown fire behavior and the application of such knowledge.



British Columbia Forest Service

Figure 9-3—Postfire mosaic associated with a portion of a high-intensity wildfire that occurred near the community of Fort Ware in north-central British Columbia in late May 1995, illustrating an alternating pattern of surface and crown fire activity. The primary fuel types in the area comprise mixtures of white spruce, Engelmann spruce, and subalpine fir, changing to the latter at higher elevations, and lodgepole pine occurring at the lower elevations.

spotting potential (Byram 1954, 1955, 1959b). Consequently, crown fires are dangerous and difficult for firefighters to control directly by conventional means (Alexander 2000a). The major run associated with the Big Scrub Fire that occurred on the Ocala National Forest in north-central Florida on March 12, 1935, constitutes a good example of the perilous nature of crowning forest fires (box 1).

Box 1:

Account of the 1935 Big Scrub Fire, Ocala National Forest, North-Central Florida (From Kendrick and Walsh 2007: 422)

The following account of this recordbreaking forest fire is drawn from national forests in Florida Historic File #5100, prepared by John W. Cooper, Ocala National Forest Ranger (1938–43).

“In the spring of 1935, the fastest spreading forest fire in the history of the U.S. Forest Service, anywhere in the United States, burned 35,000 acres in four hours on the Ocala National Forest. The fire started from

Box 1: continued

a single set, a burning stump on muck land in the southwest corner of the forest, just north of Stark’s Ferry Bridge. Blowing and jumping ahead of a 60–mph wind, this fire ran eighteen miles in a long narrow strip to the northeast, where it hit Lake George in just three hours. The wind switched suddenly to the northwest, and the fire then advanced on an eighteen-mile front for one more hour, before a downpour of rain stopped it.

The Big Scrub Fire was definitely a “crown fire”; it burned from one treetop to the next. Burning embers blew more than a mile ahead of the main blaze setting spot fires as they landed. At that time, there were 300-foot wide firebreaks every three miles across the Big Scrub. The firebreaks did not even slow the fire up. It jumped six of them in three hours.

One of the firebreaks jumped was on the Ocala-Daytona Beach Highway (SR 40) near Juniper Springs Recreation Area. Here, Forest Guard N.B. Owen and a crew of CCC enrollees attempted to make a stand by setting a backfire. When they realized their efforts were fruitless and that they would be run over by the fire, they began running to one side. In the black, smoke-caused darkness, fortunately they ran off the road and into a small pond. Here they lay on their backs with their noses above water, until the fire burned over them, only blistered noses to account for their experience.

The average speed of the Big Scrub Fire was 6 mph; 8,750 acres burned per hour, 145.8 acres burned per minute, 2.4 acres burned per second. Needless to say, the 300-foot firebreaks were abandoned, and other methods of control were sought. The best fire control in the Big Scrub is and always has been to never let a wildfire get in the sand pine.”

There is, however, a window of opportunity to suppress crown fires during the initial stages of their development in some fuel types (Crosby et al. 1963, Hesterberg 1959, Johansen and Cooper 1965). Hardy and Franks (1963), for example, found from an analysis of individual fire report data in Alaska that 70 percent of class A size fires occurring in black spruce fuel types were of a “smoldering” nature when first attacked but that 47 percent of class E size fires were crowning when they were first initial attacked (table 9-1).

Suppression actions and options at the head of high-intensity crown fires tend to be severely restricted until there is a major change in the prevailing fuel, weather, or topographic conditions (e.g., a drop in windspeed, a major change in fuel type, a significant fuel discontinuity). Consequently, crown fires are capable of burning large tracts of forested landscape, thereby placing firefighters at risk, posing a threat to public safety and properties, potentially adversely impacting other values at risk, and increasing suppression expenditures (Alexander and Cruz 2011a, Alexander et al. 2012b). Suppression activities themselves can in fact sometimes contribute to the onset of crowning (box 2).

Prolific crowning is an element or characteristic of extreme fire behavior in conifer-dominated forest cover types. This chapter constitutes a state-of-knowledge summary prepared for technical specialists in wildland fire behavior (e.g., a fire behavior analyst assigned to an incident management team or a fire behavior service center) in the

United States concerning our current understanding of the characteristics and prediction of crown fire behavior in such fuel complexes—i.e., the so-called “timber crown fire” (Albini 1984). Other “fire behaviourists” (e.g., researchers, college and university professors) as well as fire weather meteorologists and students of wildland fire will find it of value. Information on crown fire phenomenology is drawn upon from a number of sources, including relevant observations and data from Canada and Australia.

Crown fires can occur in fuel types other than conifer forests, for example, melaleuca stands in Florida (Wade 1981) or gambel oak in Colorado when the leaf foliage has been frost killed or heat desiccated (Butler et al. 1998). The dynamics of crown fires in tall brushfields (e.g., chaparral) and other forest types such as eucalypt will not specifically be dealt with here per se, although some of the general principles may be valid. Crown fire dynamics in these fuel types are dealt with extensively by others (Cheney et al. 2012; Cruz et al. 2012a, 2012b; Gould et al. 2007; Plucinski 2003; Sullivan et al. 2012). In a number of cases, however, fire behavior in conifer-dominated forests versus other fuel complexes is compared and contrasted.

For present purposes, it is assumed that there is generally a distinct separation between the canopy fuel layer and the ground and surface fuels by an open trunk space in which ladder or bridge fuels may be present (fig. 9-4). Certain aspects of crown fire behavior are not addressed here but can be found in other chapters of this synthesis.

Table 9-1—Percentage of fires by general character or type of fire behavior in Alaskan spruce fuel types at the time of initial attack in relation to final fire size over a 9-year period from 1950 through 1958

Fire size class ^a	Smouldering	Creeping	Running	Spotting	Crowning
	<i>Percent</i>				
A	70	31	12	25	7
B	19	39	41	25	17
C	6	18	22	19	19
D	2	5	5	12	10
E	3	7	20	19	47

^a Area burned: class A = less than 0.1 ha; class B = 0.1 to 4.0 ha; class C = 4.0 to 40.0 ha; class D = 40.0 to 121 ha; and class E = greater than 121 ha.

Source: Adapted from Hardy and Franks 1963.

Box 2:**Aircraft Effects on Crown Fire Behavior**

Based on his analysis of 67 fatal fires involving 222 wildland firefighter deaths in the United States over a 61-year period (1926–1976), Wilson (1977) identified some common features connecting these incidents. He found that there were common denominators of fire behavior associated with these fatal fires:

1. Most of the incidents occurred on relatively small fires or isolated sectors of larger fires.
2. Most of the fires were innocent in appearance prior to the “flareups” or “blowups.” In some cases, the fatalities occurred in the mopup stage.
3. Flareups occurred in deceptively light fuels.
4. Fires ran uphill in chimneys, gullies, or on steep slopes.

Wilson (1977) also suggested that aircraft working over wildland fires could have perilous consequences:

“Suppression tools, such as helicopters or air tankers, can adversely modify fire behavior. (Helicopter and air tanker vortices have been known to cause flare-ups.)”

The effects of vortex turbulence on fire behavior-associated aircraft have been discussed at some length (Chandler et al. 1983b, Davis and Chandler 1965, Haines 1989). Wilson (1977) pointed out that the four firefighter fatalities associated with the 1962 Timberlodge Fire on the Sierra National Forest in central California were likely related to aircraft activity over the fire:

“Loaded B-17 air tankers flew over fire. Tornado-like action from air tanker vortices probably caused fire to blow-up and trapped men.”

Countryman et al. (1969) described the circumstances that led to the deaths of a crew of eight firefighters resulting from a sudden upslope run on

the 1968 Canyon Fire that occurred near boundary of the Angeles National Forest in Los Angeles County in southern California:

“At about 1124 a patch of sumac and scrub oak ... crowned out suddenly. A fire whirl quickly formed over the hot burning bush patch ... It appears likely that a firebrand from the whirl moved down-slope and established fire well down into the ravine and below the crew ... This fire crowned immediately and ran up the ravine and over the crew ...”

It was surmised that the fire whirl that triggered the flareup was caused by a sudden and localized increase in airflow resulting from the sea-breeze front reaching the fire area. Countryman et al. (1969) suggested that “It also may have been caused by the turbulence created by the low-level passage of an air tanker through the area just before the fire flareup.”

Haines (1989) recounted an incident that occurred on the 1988 Stockyard Fire on the Hiawatha National Forest in Michigan’s Upper Peninsula as a result of a DC-4 having flown along the fire’s right flank:

“Here three tractor-plow operators built line within a jack pine plantation. The trees were 3 to 6 inches (8-15 cm) in diameter and 25 to 30 feet (7.5-9 m) high. Compared with other sectors, this was a quiet area ... Winds were light and then became calm. The low flames suddenly began to “climb” up a few trees into the crowns. Within a minute or two the flames became a high wall. The wall changed into a crown fire, moving directly toward the tractor crew ... Luckily no one was killed, although one of the tractor operators was badly injured and spent weeks in a medical burn center.”

The rotor downwash effects associated with helicopters can adversely affect fire behavior as well (Chandler et al. 1983b, Shields 1969, Slijepcevic and Fogarty 1998).

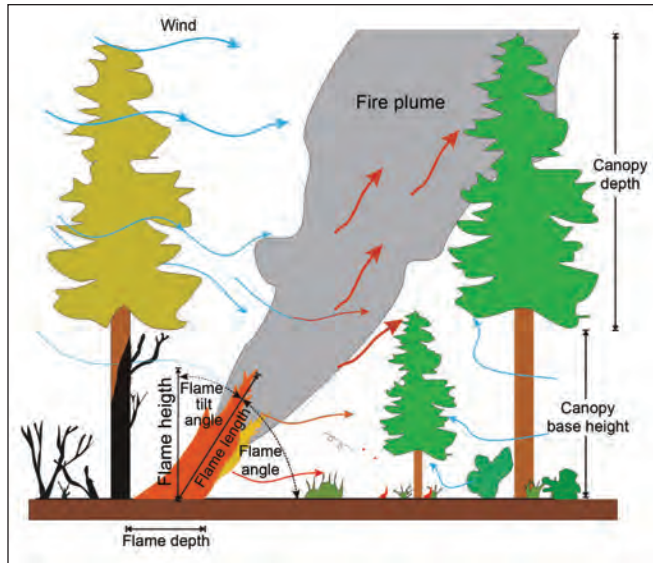

Figure 9-4—Cross section of a stylized, wind-driven surface head fire spreading behind a conifer forest canopy on level terrain.

These include, for example, horizontal roll vortices, plume- or convection-dominated crown fires, influences of atmospheric conditions aloft, and fire-atmosphere interactions.

This chapter expands upon the earlier treatment of the subject by Alexander and Cruz (2011b). The list of references has accordingly been expanded up to early 2015.

Types of Crown Fires

The term “crown fire” has appeared in the forestry and ecological literature for the last 125 years (e.g., Bell 2012) and is simply regarded as “a fire which runs in the tops of or which burns all or a large part of the upper branches and foliage of trees” (U.S. Forest Service 1930). Gradually, crown fires have come to be described by a whole host of adjectives. Harper (1944), for example, made mention of “mild,” “light,” “medium,” “heavy,” “severe,” and “very severe” crown fires in describing the immediate postburn visual evidence following crowning although he offered no specific descriptions.

Beginning in the late 1930s, two basic types or classes of crown fire came to be recognized, namely the “running crown fire” and the “dependent crown fire” (cf. Kylie et al. 1937), to distinguish the degree of independence from the

supporting surface fire. These terms are commonly attributed to Brown and Davis (1973) by most modern day authors. A running crown fire is one that generates enough heat for crown-to-crown spread, whereas a dependent crown fire depends upon the heat generated by the surface fire for its spread (Woods 1944).

For the next 40 years or so, the terms running crown fire and dependent crown fire would appear in most but not all (e.g., Barrows 1951) books, manuals, and glossaries dealing with forest fire protection (e.g., Brown and Folweiler 1953, Hawley and Stickel 1948, Luke 1961, U.S. Forest Service 1956). These terms still appear occasionally in the wildland fire behavior literature (e.g., Norum 1982, Rothermel 1991b). The terms “intermittent crown fire” and “intermittent crowning” apparently followed later on (Douglas 1957, 1964) as did the term “fully developed crown fire” (Luke and McArthur 1978).

Van Wagner (1977a) proposed that crown fires in conifer forests could be classified according to their degree of dependence on the surface fire phase, and the criteria could be described by several semimathematical statements (fig. 9-5). He recognized three types of crown fires: passive, active, and independent (box 3).

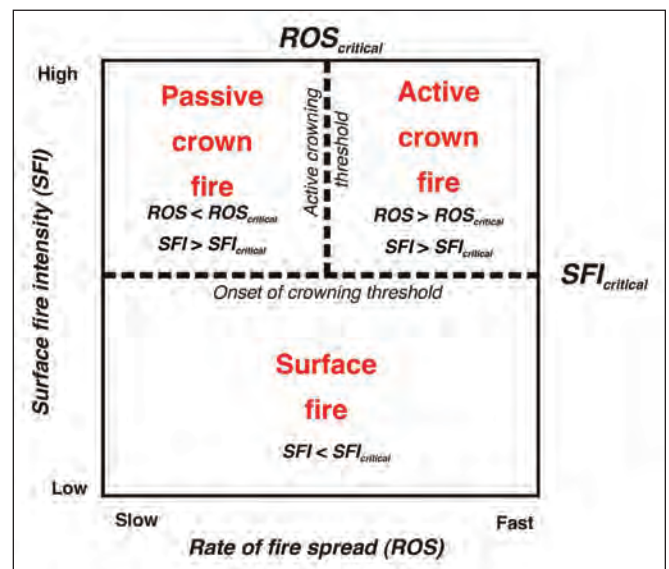

Figure 9-5—Type of fire classification scheme based on Van Wagner’s (1977a) theories regarding the start and spread of crown fires in conifer forests.

Box 3:**Crown Fire Classification**

Van Wagner (1977a) recognized three classes or types of crown fires:

Passive Crown Fire

Passive or dependent crown fires can involve a portion or all of the canopy fuel layer in combustion, but the overall rate of spread is largely determined by the surface phase. Passive crown fires cover a range in fire behavior from moderately vigorous surface fires with frequent crown ignition occurring behind the surface flame front up to high-intensity surface fires spreading with an almost solid flame front occupying the canopy and subcanopy or trunk space that have nearly achieved the critical minimum spread rate for active crowning. Passive crown fires can occur under two broad situations. First, the canopy base height and canopy bulk density (CBD) are considered optimum, but fuel moisture and wind conditions are not quite severe enough to induce full-fledged crowning (fig. 9-1B). Second, the canopy base height (CBH) and CDB are, respectively, above and below the thresholds generally considered necessary for crowning (e.g., tall or open-forest stand types), so that even under severe burning conditions (i.e., critically dry fuels and strong surface winds), active crown fire spread is not possible, although vigorous, high-intensity fire behavior can occur (e.g., National Fire Protection Association 1990).

Active Crown Fire

Active or running crown fires are characterized by the steady advancement of a tall and deep coherent flame front extending from the ground surface to above the top of the canopy fuel layer (fig. 9-1C). The surface and crown phases are intimately linked, but fire propagation is largely determined by the crown phase. The spread of active crown fires requires (1) relatively dry and plentiful surface fuels that allow for the development of a substantial surface fire, (2) low to moderately high CBH, and (3) a fairly continuous crown layer of moderate to high CBD ($>0.1 \text{ kg/m}^3$) and low to normal foliar moisture content (e.g., National Fire Protection Association 1991).

Independent Crown Fire

An independent crown fire no longer depends in any way on the surface phase, spreading ahead of

the surface phase in the crown fuel layer entirely on its own. Stand conditions favoring an independent crown fire are a continuous crown layer of low to moderate CBD and an abnormally low foliar moisture content. For a truly independent crown fire to develop on flat topography would require very strong, sustained winds. In mountainous terrain, slope steepness would no doubt compensate for a lesser wind velocity.

Of Note

The vast majority of crowning forest fires spread either as passive or active crown fires, each controlled by a different set of processes. Van Wagner (1993) acknowledged that the concept of a truly independent crown fire as a stable phenomenon on level terrain is dubious but that it “may still have value in rough or steep terrain and as a short-term fluctuation under the most extreme conditions.” Indeed, there are reports of the flames in the crown extending 50 to 150 m ahead of the surface burning in momentary bursts and of crown fires spreading through closed-canopied forests up steep, partially snow-covered slopes in the spring (Mottus and Pengelly 2004). These incidents might possibly give the appearance of being evidence for independent crown fires. However, there is no steady-state propagation as seen with passive and active crown fires.

Noteworthy is that the concept of passive crowning implies an element of forward movement or propagation of the flame front. The incidental ignition of an isolated tree or clump of trees, with the flames spreading vertically from the ground surface through the crown(s) without any form of forward spread following, does not constitute passive crowning. Flame defoliation of conifer trees by what amounts to stationary torching or “crowning out,” especially common during the postfrontal combustion stage following passage of the surface fire, generally does not generate any kind of horizontal spread.

Scott and Reinhardt (2001) claimed that the possibility exists for a stand to support an active crown fire that would otherwise not initiate a crown fire. They referred to this situation as a “conditional surface fire.” Later on, Scott (2006) termed this a “conditional crown fire.” To our knowledge, no empirical proof has been produced to date to substantiate the possible existence of such a situation, at least as a steady-state phenomenon.

According to Van Wagner (1977a), the class or type of crown fire to be expected in a conifer forest on any given day depends on three simple properties of the canopy fuel layer (box 4) and two basic fire behavior characteristics:

- Initial surface fire intensity
- Foliar moisture content
- Canopy base height
- Canopy bulk density
- Rate of fire spread after the onset of crown combustion.

The first three quantities determine whether a surface fire will ignite coniferous foliage. The last two determine whether or not a continuous flame front can be sustained in the canopy fuel layer. A dichotomous key to a forest fire classification scheme incorporating Van Wagner's (1977a) three classes of crown fire and the corresponding theory has been prepared by Alexander (1988).

The initial surface fire intensity and rate of fire spread after the onset of crown combustion would, in turn, include the effects of windspeed, slope steepness, fuel dryness, air temperature, relative humidity, and fuel complex characteristics. As Van Wagner (1977a) noted, ladder or bridge fuels (e.g., loose bark and dead bole branches on tree boles, lichens, shrubs, and small conifers) in the space between the ground surface and the canopy "must presumably be present in sufficient quantity to intensify the surface fire appreciably as well as to extend the flame height."

Albini and Stocks (1986) considered the factors included in Van Wagner's (1977a) proposed criteria for the start and spread of a crown fire as "heuristically valid." Subsequent experience and analysis has shown both the strengths and limitations of his approach (Alexander and Cruz 2006; Cruz et al. 2003c, 2004, 2005, 2006a).

Unfortunately, our ability to assess ladder or bridge fuel effects on crown fire initiation remains largely qualitative in spite of its obvious importance (Kilgore and Sando 1975, LaMois 1958, Lawson 1972, McArthur 1965, Muraro 1971, Sackett 1975). Fahnestock (1970), for example, developed a dichotomous key on the basis of "observations and deductions by the author" that identifies the nature of ladder fuel and general tree crown characteristics that are conducive to

Box 4:

Canopy Fuel Characteristics in Van Wagner's (1977a) Crown Fire Initiation and Propagation Models

Canopy Base Height

Canopy base height (CBH) represents the mean height from the ground surface to the lower live crown base of the conifer trees in a forest stand (fig. 9-4). The CBH is dependent on the mean tree height and live-stem density (fig. 9-6).

Canopy Bulk Density

Canopy bulk density (CBD) represents the amount of available crown fuel within a unit volume of the canopy. The CBD is computed by dividing the canopy fuel load (CFL) by the canopy depth (fig. 9-4), which represents the average tree height of the stand minus the CBH. The CFL represents the quantity of crown fuel typically consumed in a crown fire, principally needle foliage. Both the CBD and CFL are in turn functions of stand structure characteristics (figs. 9-7 and 9-8).

Foliar Moisture Content

Foliar moisture content (FMC) represents a weighted average or composite moisture content for the various needle ages found within the canopy fuel layer. Needles decrease in moisture content with age following their initial flushing (Keyes 2006). Chandler et al. (1983a) considered that "A general rule of thumb with regard to living foliage moisture is that crown fire potential in conifers is high whenever needle moisture drops below 100 percent of dry weight."

Of Note

Some authors such as Scott and Reinhardt (2001) have applied different criteria to the CBH, CFL and CBD inputs in their use of Van Wagner's (1977a) models. However, **strictly speaking such ad hoc adjustments or modifications are not compatible with the use of these models** (Cruz and Alexander 2010a, 2012). Still others have in some cases recommended or applied potentially unrealistically low values of FMC (Cruz and Alexander 2010a).

Box 4 continued

Affleck et al. (2012) recently undertook a state-of-knowledge review on the subject of crown fuel modeling in relation to fire behavior modeling systems. They highlighted the primary limitations of current crown fuel models and suggested ways of incorporating work carried out on tree crown architecture in the other fields of forestry research.

Reinhardt et al. (2006) questioned the validity of the regression equations for estimating CBH in coniferous forest fuel types developed by Cruz et al. (2003a) to produce logical results when applied to simulations involving low thinning. This turns out to be an error in interpretation on their part with regard to the stand height input parameter (Cruz et al. 2010b).

Repeated FMC sampling of coniferous tree foliage at several locations across Canada (e.g., Chrosiewicz 1986b, Van Wagner 1967c) has revealed a common pattern or cycle during the fire season, namely a period of relatively low values in the spring and early summer before the emergence of new needles. This phenomenon is commonly referred to as the “spring dip” (Van Wagner 1974). This seasonal pattern in FMC observed in Canada appears to occur in adjacent areas in jack pine and red pine in the U.S. Lake States region (Dieterich 1963; Johnson 1966), for example, and for several Western U.S. conifers as well black spruce in Alaska (Alexander 2010a) and in sand pine in Florida (Hough 1973). Building on an earlier compilation of the literature on FMC by Alexander (1988), Keyes (2006) has prepared an excellent summary for North America.

crowning (table 9-2). The key ranks crowning potential by increasing numbers from 0 to 10. The ratings are arbitrary values and indicate the likely order of sustained crown fire development and are not to be construed as a proportionality or probability of occurrence (Rothermel 1983). Similarly, Menning and Stephens (2007) devised a semiquantitative, semiquantitative method of assessing four categories of ladder fuel hazard based on clumping of low aerial fuels, canopy base height, and maximum gaps in vertical fuel ladders. However, like the Fahnestock (1970) key, the approach has no physical basis.

Examples of how canopy fuel properties differ in relation to specific tree and stand characteristics are presented in figures 9-6, 9-7, and 9-8 for four common forest fuel types found in the Western United States and Canada; tabulations can be found in Alexander and Cruz (2014). Similar models have been produced for the eastern half of North America as well (e.g., Agca et al. 2011, Bilgili and Methven 1994, Duveneck 2005, McAlpine and Hobbs 1994, Parresol 2007). An indication of the variation in canopy fuel load and bulk density with height above ground and within a given forest fuel type is presented in figure 9-9. Similar canopy fuel profiles have been constructed for other forest fuel types (e.g., Kilgore and Sando 1975, Sando and Wick 1972, Scott and Reinhardt 2005).

Crown Fire Initiation

In regards to predicting crown fire behavior, Rothermel and Andrews (1987) determined that the most significant issue was determining whether a surface fire will develop into a crown fire (i.e., identifying the conditions for the onset of crowning). For a crown fire to start, a surface fire is necessary (Malchanov 1957). The questions then become:

- How do we define fire intensity in terms that would be useful in predicting the onset of crowning?
- And, just how intense is intense enough with respect to the convective and radiative energy transferred upward to the canopy fuels (Byram 1957) that would be necessary to initiate crowning?

Quintilio et al. (1977) offers an excellent description of the crowning phenomenon based on an experimental burning project in natural jack pine stands in northeastern Alberta, Canada (box 5); see Alexander and De Groot (1988) for color photographs of the experimental fires. Van Wagner (1964) observed that “a deep burning front seems necessary to initiate and sustain crowning.”

The distance the canopy fuel layer (fig. 9-4) is from the heat source at the ground surface will dictate how much energy is dissipated before reaching the fuels at the base of the canopy. The higher the canopy base, the less chance of crowning (Malchanov 1957). Furthermore, if the moisture content of the canopy fuels is high, greater amounts of energy are required to raise the tree foliage to ignition temperature.

Table 9-2—Fahnestock’s crowning potential key

Ladder fuel and general tree crown characteristics	Rating
A. Foliage present, trees living or dead - B	
B. Foliage living - C	
C. Leaves deciduous or, if evergreen, usually soft, pliant, and moist; never oily, waxy, or resinous	0 ^a
CC. Leaves evergreen, not as preceding - D	
D. Foliage resinous, waxy or oily - B	
E. Crowns dense - F	
F. Ladder fuels plentiful - G	
G. Canopy closure 75 percent	9
GG. Canopy closure less than 75 percent	7
FF. Ladder fuels sparse or absent - H	
H. Canopy closure 75 percent	7
HH. Canopy closure less than 75 percent	5
EE. Crowns open - I	
I. Ladder fuels plentiful	4
II. Ladder fuels sparse or absent	2
DD. Foliage not resinous, waxy or oily - J	
J. Crowns dense - K	
K. Ladder fuels plentiful - L	
L. Canopy closure 75 percent	7
LL. Canopy closure less than 75 percent	7
KK. Ladder fuels sparse or absent - M	
M. Canopy closure 75 percent	5
MM. Canopy closure less than 75 percent	3
JJ. Crowns open - N	
N. Ladder fuels plentiful	3
NN. Ladder fuels sparse or absent	1
BB. Foliage dead - O	
O. Crowns dense - P	
P. Ladder fuels plentiful - Q	
Q. Canopy closure 75 percent	10
QQ. Canopy closure less than 75 percent	9
PP. Ladder fuels sparse or absent - R	
R. Canopy closure 75 percent	8
RR. Canopy closure less than 75 percent	4
OO. Crowns open - S	
S. Ladder fuels plentiful	6
SS. Ladder fuels sparse or absent	2
AA. Foliage absent, trees dead - T	
T. Average distance between trees 10 m or less - U	
U. Ladder fuels plentiful - V	
V. Trees with shaggy bark and/or abundant tinder	10
VV. Trees without shaggy bark and/or abundant tinder	8
UU. Ladder fuels sparse or absent - W	
W. Trees with shaggy bark and/or abundant tinder	10
WW. Trees without shaggy bark and/or abundant tinder	5
TT. Average distance between trees 10 m	2

^a Rare instances of crowning have been reported, resulting from extreme drought conditions.

Source: Adapted from Fahnestock 1970.

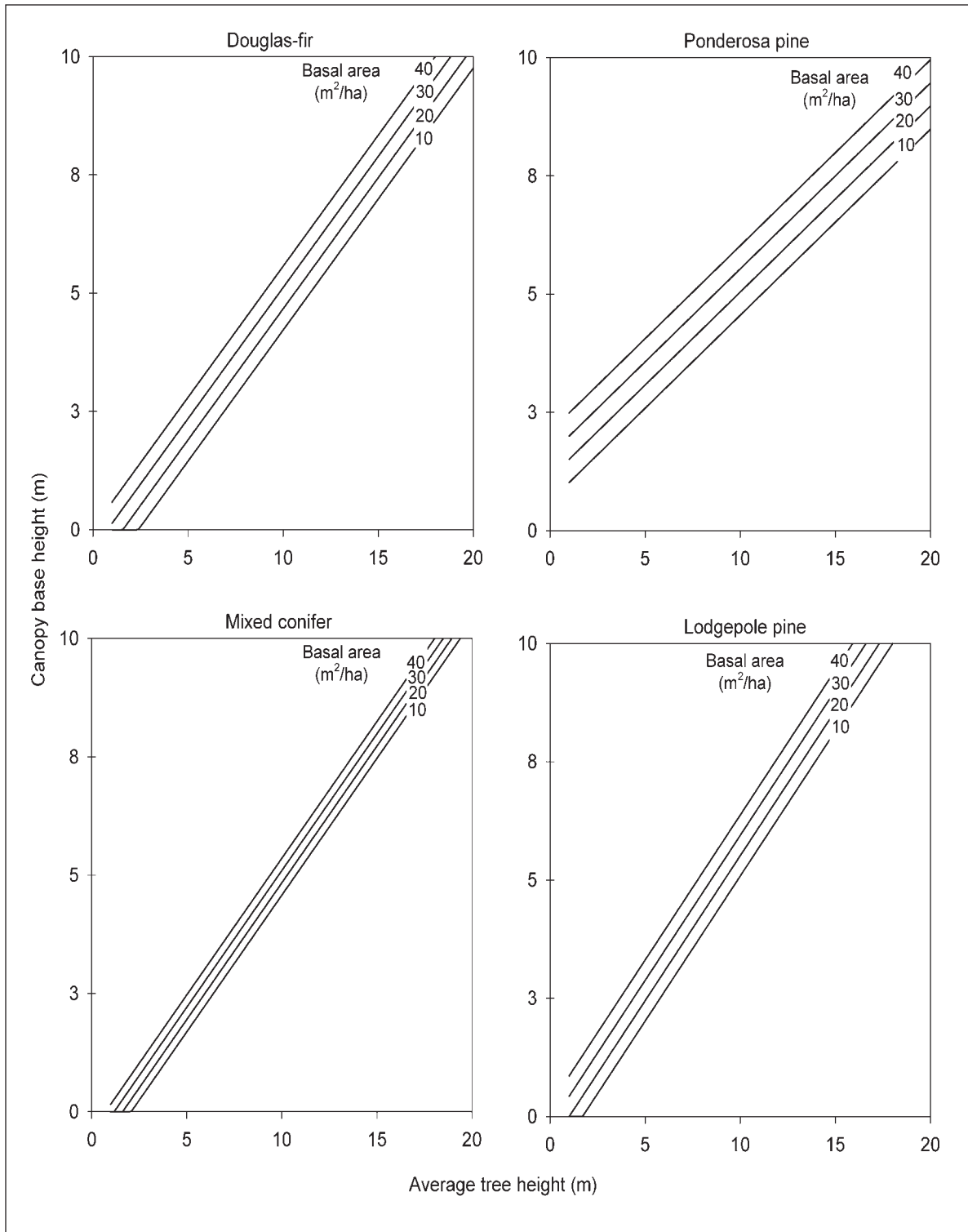

Figure 9-6—Canopy base height for four Western U.S. conifer forest fuel types as a function of average stand height and basal area according to Cruz et al. (2003a). The regression equations used to produce these graphs are not valid for tree heights of less than 1.0 m in the case of ponderosa pine, 2.0 m in the case of Douglas-fir, and 3.0 m in the case of lodgepole pine and mixed conifer (Alexander and Cruz 2010).

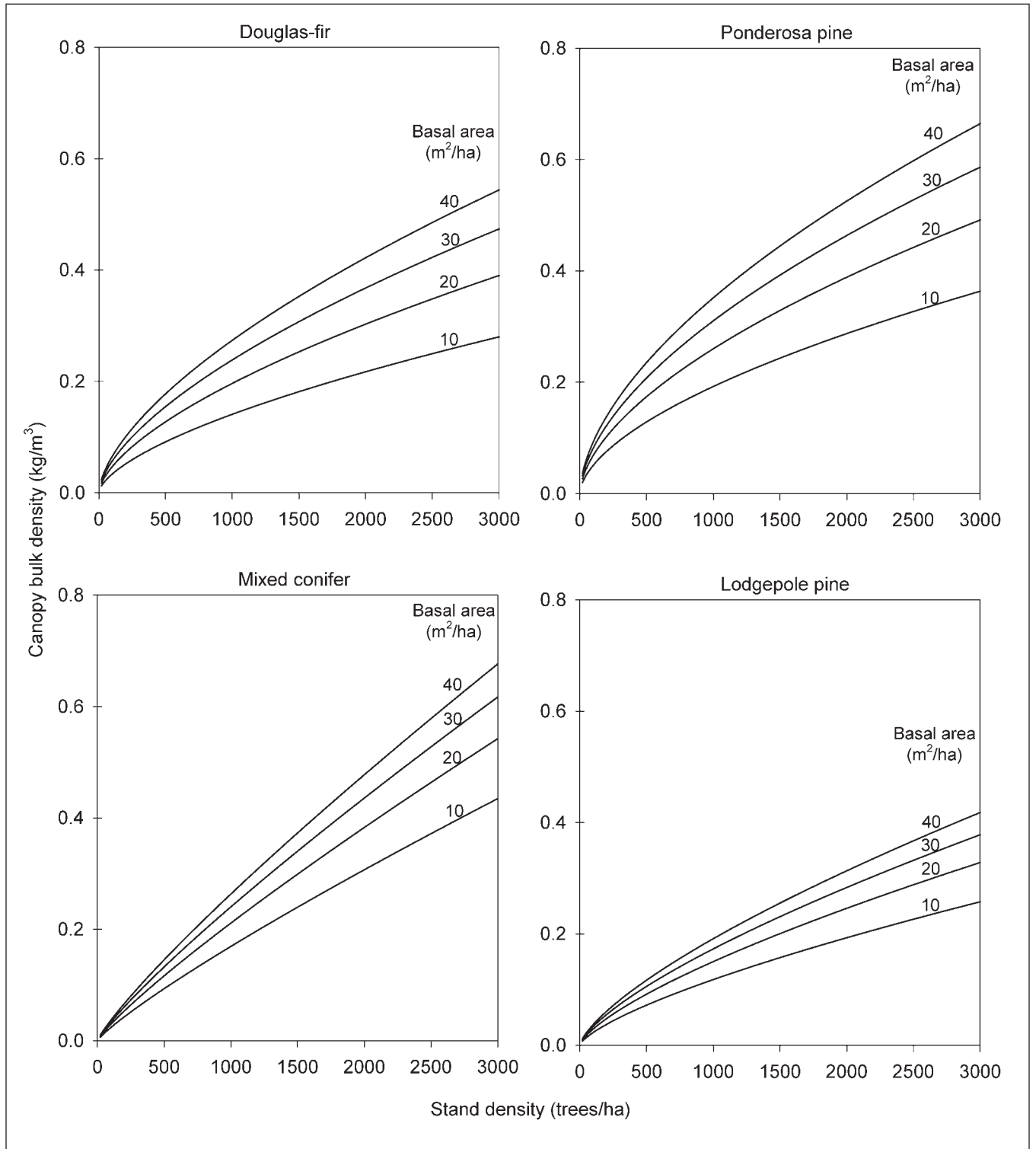

Figure 9-7—Canopy bulk density for four Western U.S. conifer forest fuel types as a function of stand density and basal area according to Cruz et al. (2003a). The regression equations used to produce these graphs do have upper limits in terms of both stand density and basal area (see Alexander and Cruz 2010).

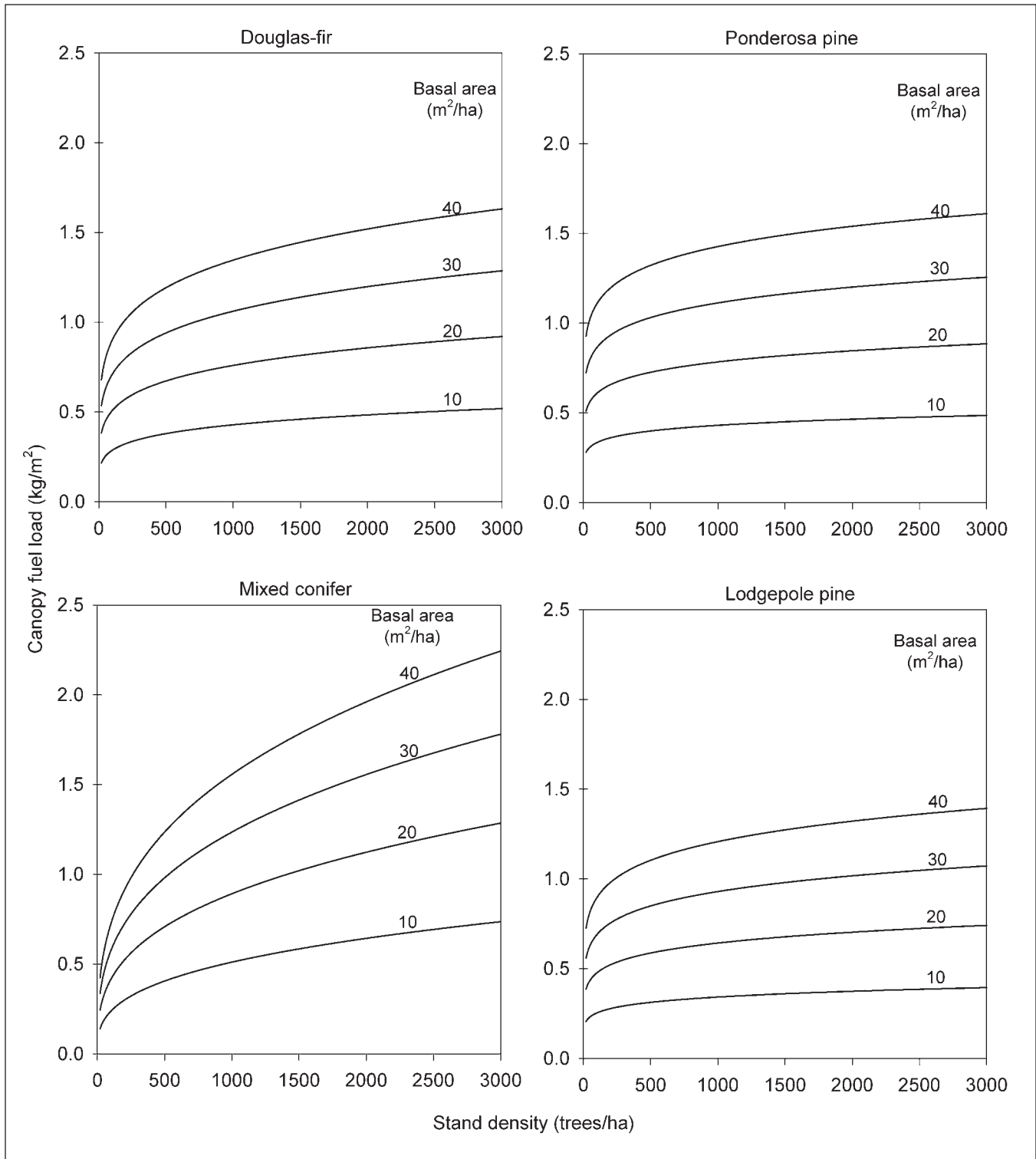

Figure 9-8—Canopy fuel load for four Western U.S. conifer forest fuel types as a function of stand density and basal area according to Cruz et al. (2003a). The regression equations used to produce these graphs do have upper limits in terms of both stand density and basal area (see Alexander and Cruz 2010).

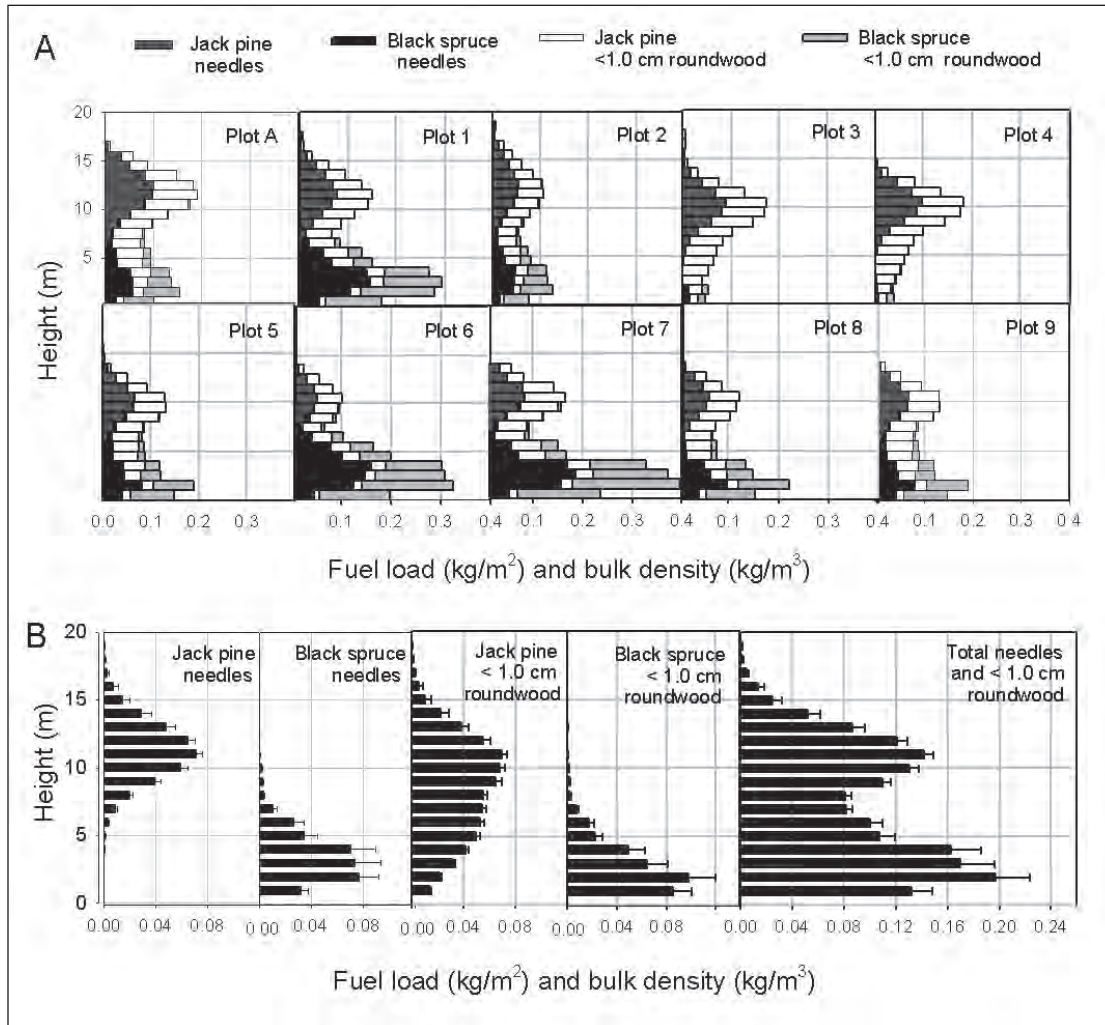

Figure 9-9—Vertical fuel profiles (with standard error bars) of the individual crown fuel components found in the jack pine – black spruce fuel complex associated with the International Crown Fire Modelling Experiment carried out in the Northwest Territories of Canada for (a) individual plots and (b) for the study area as a whole (adapted from Alexander et al. 2004). To view the variation with stand age in this fuel type, see Lavoie et al. (2010).

Box 5:**Summary of Surface to Crown Fire Interaction Observed in Natural Jack Pine Stands During the Darwin Lake Experimental Burning Project in Northeastern Alberta, Canada (after Quintilio et al. 1977)**

“On-site observations and examination of a series of 35-mm slides provided several interesting fire behavior descriptions of surface to crown interaction. Crown involvement ranged from a silent flash in the beard lichens to a solid flame front of greater intensity than the surface fire. Flame height on Units 1 and 3 averaged less than 0.5 m yet the lichens carried flame into the tree crown for very brief periods. Bark flakes on Units 4a and 4b were burning the length of the trees and out into the branches, but even an intense core of fire surrounding the tree trunk for its full length was not enough to torch out the average tree. Full crowning developed only when the surface fire was intense and continuous enough to preheat the lower needle foliage and branchwood over a large area, a condition which occurred only on Unit 6. Flame heights of the initial surface fire, which occurred on Unit 6, were well into the canopy layer, resulting in simultaneous ignition of bark flakes and needles. Although the fire front leaned slightly downwind, the crown fire did not move independently of the surface fire.

Stand density and height of aerial fuels seemed to affect crown involvement significantly during fires conducted under ‘moderate’ and ‘high’ fire danger conditions. Units 4a and 4b were of mixed density, and height and fire behavior differences were noted at the fuel type boundaries. The west side of the plots was denser, and ladder fuels extended to within a meter of the ground. Fire spread was slower and more uniform in this area, with very little torching, presumably a result of higher moisture contents from shade effect. On the more open east side of the plots, spread was faster and the surface fuels more intense, which promoted torching even though ladder fuels were higher and less concentrated horizontally. At the “extreme” level of fire danger, on Unit 6, crowning occurred throughout the plot regardless of density and crown height variations.”

To view the photographs associated with the Darwin Lake experimental fires, see Alexander and De Groot (1988).

Byram (1959a) defined fireline intensity (I , kW/m) as the rate of heat released from a linear segment of the fire perimeter as calculated by the following equation:

$$I = H \times w \times r \quad (1)$$

where, in compatible International System (SI) units, H is regarded as the net low heat of combustion (kJ/kg), w is the amount of fuel consumed in the active flaming front (kg/m²), and r is the rate of fire spread (m/s) (Alexander 1982).³ Flame size is its main visual manifestation (Alexander and Cruz 2012a, 2012b). For photographic examples illustrating a wide range in I for a surface fire and crown fires in a given fuel type, see Alexander and De Groot (1988), Alexander and Lanoville (1989), Hirsch et al. (2000), and Stocks and Hartley (1995).

Byram (1959a) established an empirical relationship between I_B and flame length for surface fires that is widely applied in wildland fire science and management (from Alexander 1982):

$$L = 0.0775 \times I^{0.46} \quad (2)$$

where L is flame length (m) as illustrated in fig. 9-4.⁴ For photographic examples of surface flame lengths, see Brose (2009) and Wade et al. (1993).

If we assume $H = 18\,000$ kJ/kg, then equation (1) can in turn be expressed as follows (Forestry Canada Fire Danger Group 1992):

$$I = 300 \times w \times ROS \quad (3)$$

where ROS is the rate of fire spread given in m/min. A graphical representation of this relation showing the hyperbolic or inverse function between w and ROS is presented in fig. 9-10 in the form of a fire behavior characteristics chart

³ Note that several authors have failed to present the correct SI units for the input variables associated with equation (1) (e.g., Fryer and Johnson 1988, Johnson and Gutsell 1993, Johnson and Miyanishi 1995), the SI unit version of Byram’s (1959a) original $L - I$ relation represented by equation (2) (e.g., van Wagendonk 2006), and the inverse of equation (2) (e.g., Chandler et al. 1983a, DeBano et al. 1998), namely $I = 259.833 \times L^{2.174}$.

⁴ Note that the 0.46 exponent in Byram’s (1959a) flame length – fireline intensity equation presented in footnote a of table 8-1 of Alexander and Cruz (2011b) was improperly presented.

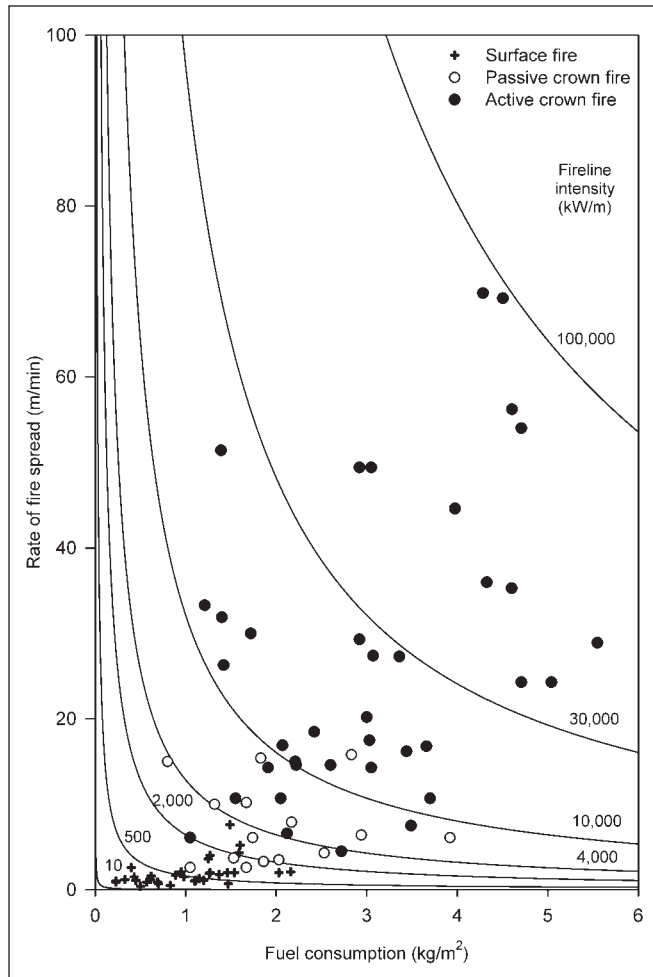

Figure 9-10—Head fire rate of spread and fuel consumed in relation to the type of fire and six distinct levels of Byram’s (1959a) fireline intensity, assuming a net heat of combustion of 18 000 kJ/kg, for the experimental surface and crown fires used in the development and testing of the onset of crowning and spread rate functions in the Crown Fire Initiation and Spread modeling system (Cruz et al. 2003b, 2004, 2005).

(Alexander et al. 1991) along with plotted experimental fire data. This chart is patterned after the original work of Rothermel and Anderson (1966) and later extended by Andrews and Rothermel (1982), Rothermel (1991a), and Andrews et al. (2011).

Wendel et al. (1962) concluded that the probability of blowup fires decreased rapidly when available fuel loads were less than 1.35 kg/m², a value that is commonly exceeded in certain forest cover types such as Southwestern

U.S. ponderosa pine and mixed-conifer stands for example (Sackett 1979). Violent physical behavior approaches certainty as fireline intensities begin to exceed 10,000 kW/m, in which case, suppression actions at the head and along the upper flanks must cease until burning conditions ameliorate (Sibley 1971).

Several empirical and semiphysical models have been developed over the past 20 years or so for predicting the initiation or onset of crowning (e.g., Alexander 1998; Cruz 1999, 2004), including one (Xanthopoulos 1990, Xanthopoulos and Wakimoto 1991) intended for use with the BEHAVE System (Andrews 1986, Andrews and Chase 1989). However, the simplest explanation of the general processes involved is offered by Van Wagner (1977a). Using physical reasoning and empirical observation, Van Wagner (1977a) proposed that vertical fire spread could occur in a conifer forest stand when the surface fire intensity (*SFI*) attains or exceeds a certain critical surface intensity for combustion (*SFI_{critical}*, kW/m) as dictated by the foliar moisture content (FMC, %) and the canopy base height (CBH, m) according to the following equation (box 6), which is graphically presented in fig. 9-11:

$$SFI_{critical} = (0.01 \times CBH \times h)^{1.5} \quad (4)$$

where *h* is the heat of ignition (kJ/kg) and is turn determined by the following equation (Van Wagner 1989, 1993):

$$h = 460 + 25.9 \times FMC \quad (5)$$

Thus, according to Van Wagner’s (1977a) theory of crown fire initiation, if *SFI* > *SFI_{critical}*, some form of crowning is presumed to be possible, but if *SFI* < *SFI_{critical}*, a surface fire is expected to prevail (fig. 9-5). In applying the criterion represented by equation (4), it is assumed that (1) that a conifer forest stand possesses a minimum canopy bulk density that will allow flames to propagate vertically through the canopy fuel layer and (2) bridge or ladder fuels such as bark flakes on tree boles (Taylor et al. 2004), tree lichens (Agee et al. 2002), shrubs and understory trees (Reifsnyder 1961, Stocks 1989), dead bole branches (Lawson 1972), and suspended needles (Burrows et al. 1988, McArthur 1965) exist in sufficient quantity to intensify the surface fire and extend the flame height (Van Wagner 1977a).

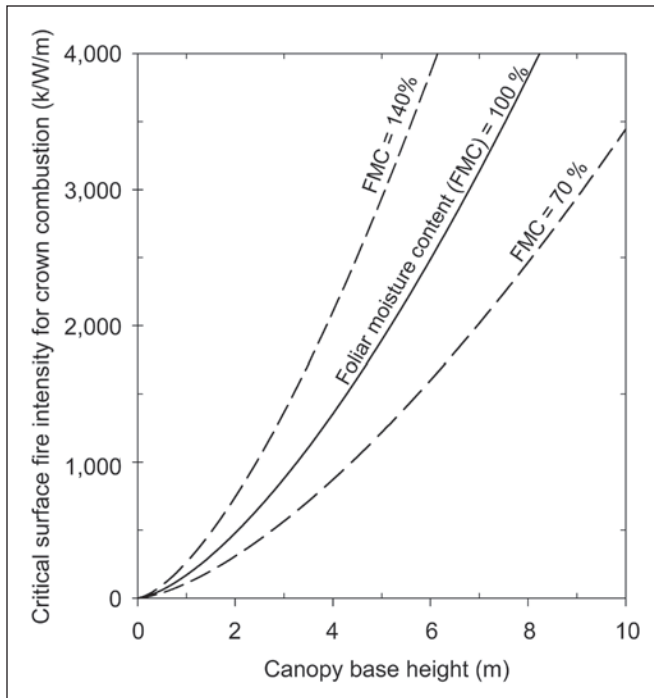

Figure 9-11—Critical surface fire intensity for crown combustion in a conifer forest stand as a function of canopy base height and foliar moisture content according to Van Wagner (1977a).

One of the appealing aspects of equation (4) is its simplicity, but with this comes a major underlying assumption. According to Van Wagner (1977a), the 0.01 value given in equation (4) is “best regarded as an empirical constant of complex dimensions whose value is to be found from field observations.” He derived this value from an outdoor experimental fire in a red pine plantation stand with CBH of 6.0 m and a FMC of 100 percent⁵ and the *SFI* was about 2,500 kW/m just prior to the onset of crowning (box 6) (Van Wagner 1968). This widely used relation represented by equation (4) therefore incorporates a fixed set of burning conditions, fuel characteristics, and surface fire behavior (e.g., in-stand windspeed, ladder fuels, fuel consumed, flame depth, and spread rate). Subsequent research has shown this empirical constant to be a variable quantity dependent on these factors (Alexander 1998, Cruz et al.

⁵ This is incidentally the general default value as suggested for FMC by Scott and Reinhardt (2001) and Agee et al. (2002). Keyes (2006) on the other hand recommended 90 or 100 percent as a “prudently conservative” default value.

Box 6:

The Origins of Van Wagner’s (1977a) Equation for Determining the Initiation of Crowning

Van Wagner (1999) readily acknowledged that the previous works of Thomas (1963, 1967) and Thomas et al. (1964) were critical to the development of his equations for judging the requirements needed for crown fire initiation and continuous crown fire spread. Van Wagner’s (1977a) theory for the initiation of crowning is founded on the combining of two basic equations. The first equation concerns the temperature rise above ambient air conditions (ΔT) reached at height z above a line fire of intensity I burning on the surface (after Thomas 1963):

$$\Delta T \propto I^{2/3} z$$

The second equation involves the heat energy required to raise the crown foliage to ignition temperature (after Van Wagner 1968):

$$h = 460 + 25.9 \times m$$

where m is the moisture content of the canopy foliage (percentage oven-dry weight basis) and h is the heat of ignition (kJ/kg).

Assuming that the ΔT required for crown ignition at an arbitrary value of h , which we will call h_o , and that the actual ΔT at z or the canopy base height varies with the ratio of h/h_o . The left-hand side of Thomas’ (1963) relation given above then becomes $\Delta T \cdot h/h_o$. We thus have:

$$\Delta T (h/h_o) \propto I^{2/3}/z$$

Replacing $\Delta T/h_o$ with an empirical quantity C , termed the criterion for initial crown combustion, ultimately yields the following equation:

$$I_o = (C \times z \times h)^{3/2}$$

where I_o is now the critical surface fire intensity needed to initiate crowning. The value of 0.010 derived for C by Van Wagner (1977a) in turn relied upon a rearrangement of the above equation:

$$C = I_o^{2/3} / (z \times h)$$

This equation was inadvertently presented in error in Alexander (1998: 32) and Alexander (2006: 190).

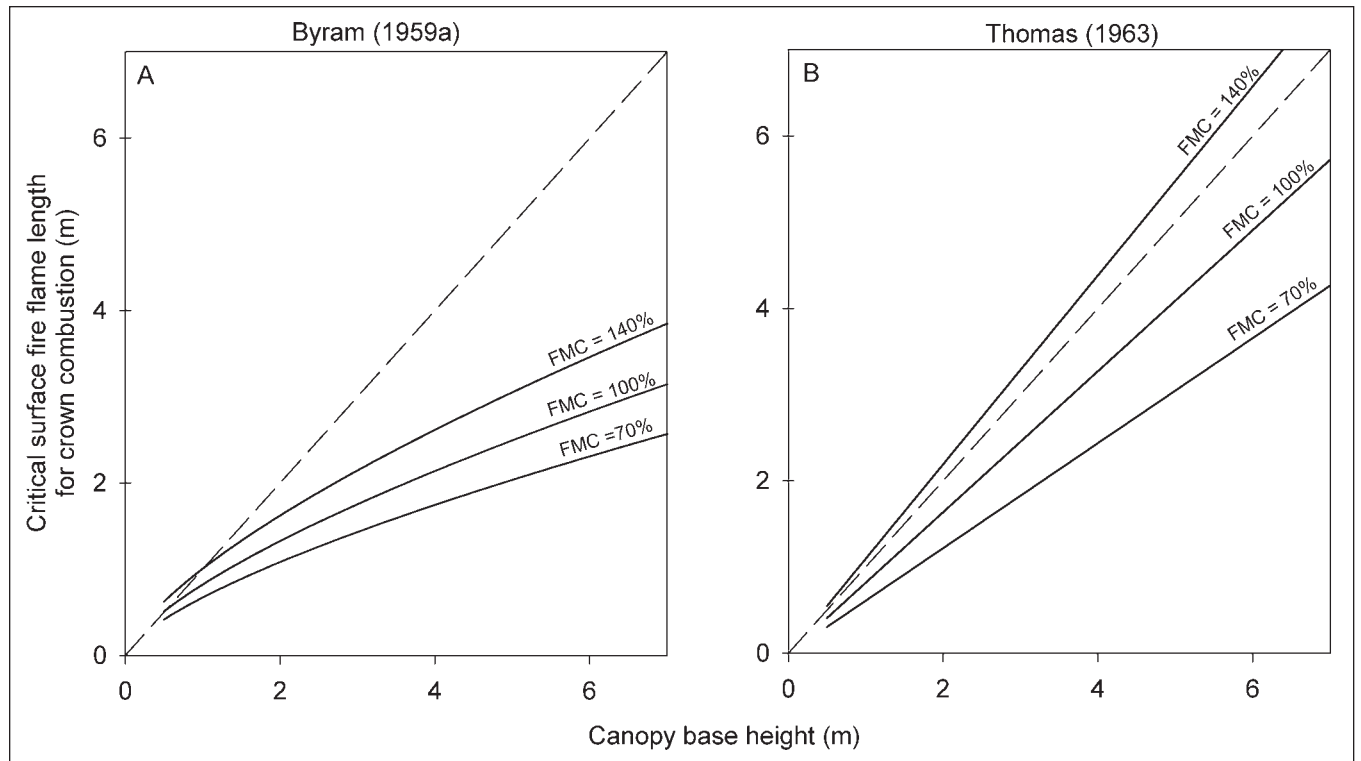

Figure 9-12—Critical surface fire flame length for crown combustion in a conifer forest stand as a function of canopy base height according to the flame length-fireline intensity models of (A) Byram (1959a) and (B) Thomas (1963) based on Van Wagner’s (1977a) crown fire initiation model for various foliar moisture contents. The dashed line represents the boundary of exact agreement between flame length or height and canopy base height.

2006a). Catchpole (1987), for example, derived an empirical constant of 0.0513 in lieu of 0.01 for a heathland fuel complex in New South Wales, Australia, in a manner similar to Van Wagner (1977a).

Figure 9-11 clearly shows that the higher the CBH or FMC, the more intense a surface fire must be to cause crowning. Note that the flames of a surface fire do not necessarily have to reach or extend into the lower tree crowns to initiate crowning (Alexander 1988, Alexander and Cruz 2012a) (fig. 9-12). The experimental fire used by Van Wagner (1977a) to parameterize his crown fire initiation model represented by equation (4) would, for example, have had just prior to the onset of crowning, a flame length of around 2.8 m according to Byram’s (1959a) formula linking flame length to fireline intensity represented by equation (2) (Alexander 1988). Rossotti (1993) indicated that “leaves from the forest canopy may ignite if they are no more distance than one and a half times the flame height,” although she offered no basis for this pronouncement.

Equation (5) defines the heat energy required to drive off the moisture content in the crown foliage and raise it to its ignition temperature. Van Wagner (1977a) assumed that all of the moisture in the fuel must be driven off before ignition can occur. Pickett et al. (2010) has recently shown in the laboratory with green leaf samples of various shrub species that some moisture can remain in the leaf after ignition occurs.

The effect of FMC on the onset of crowning represented by equation (5) has not been corroborated by field data. This is not to say that the derivation of equation (5), as originally described by Van Wagner (1967a, 1967c, 1968), is not technically accurate. However, while the effect of FMC on foliar ignition (Xanthopoulos 1990, Xanthopoulos and Wakimoto 1993) and vertical fire propagation in individual trees (Van Wagner 1967b) has been demonstrated in the laboratory, a statistical analysis of an experimental dataset comprising surface and crown fires in coniferous forests

failed to find a significant effect of FMC on the likelihood of crown fire occurrence (Cruz et al. 2004). Sensitivity analysis of the physics-based crown fuel ignition model developed by Cruz et al. (2006a) identified a weak effect of FMC on the ignition of canopy fuels by a surface fire in the range of 80 to 160 percent. A possible explanation of this weak effect could be that the change in energy required to ignite canopy fuels owing to the increase in FMC is relatively small when compared to the cumulative energy flux absorbed by crown fuels above a high-intensity surface fire (Cruz et al. 2006b).

Ideal evidence to substantiate an FMC effect on crown fire initiation would be a set of experimental surface and crown fires carried out under nearly identical burning conditions, with FMC thus being the only variable. Such an experiment would be difficult to arrange under field conditions (Van Wagner 1971, 1979a).

Norum (1975) offered the following observation regarding a crowning tendency in relation to FMC in connection with a study of 20 understory fires carried out in western larch–Douglas-fir stands in western Montana:

One ... phenomenon which was obvious to all members of the research team was the greater prevalence of crown fires in the late spring and early summer fires. Douglas-fir of all sizes were prone to support fire in the crowns during this season. Conversely, high intensity fires in late summer and early fall presented almost no such problems. Many cases were observed where complete scorching of crowns and total bole cambium kill occurred without ignition of the crowns in the late summer and early fall fires. No explanation of this phenomenon can be offered now, and more study is needed, but it was obviously true in this set of fires.

Norum (1975) made no mention of the study by Philpot and Mutch (1971), which indicated that the moisture content of 1- and 2-year-old needles of Douglas-fir increased from late spring to early fall. It was only later on that he attributed the crowning tendency he had observed to FMC (Norum and Miller 1984).

Given the empirical nature of Van Wagner's (1977a) crown fire initiation model with respect to the FMC, applying it and any of the fire modeling systems that utilize it to insect- and disease-killed stands (Alexander and Stam 2003, Klutsch et al. 2011, Kuljian and Varner 2010, Schoennagel et al. 2012, Simard et al. 2011) is highly inappropriate (Page et al. 2014); in fact, crowning is but one factor to consider in such fuel complexes (Page et al. 2013a). What is needed is an empirical constant for use in equation (4) that is based on lower FMC values than is presently the case (Jenkins et al. 2012; Kuljian 2010; Page et al. 2014). The reduction in FMC in mountain pine beetle (*Dendroctonus ponderosae*)—attacked lodgepole pine stands has recently been documented by Jolly et al. (2012) and Page et al. (2012). Clearly, FMC values of “red and dead” needles on mountain pine beetle-attacked lodgepole pine trees can, depending on weather conditions, approach levels as low (say 5 to 10 percent) as those found in exposed surface needle litter (Pook and Gill 1993), although Page et al. (2013b) found that there was little diurnal variation in FMC.

Crown Fire Propagation

Assuming a surface fire is intense enough to initiate and sustain crown combustion from below, the question now becomes, Can a solid flame front develop and maintain itself within the canopy fuel layer in order for horizontal crown fire spread to occur? Van Wagner (1977a) theorized that a minimum flow of fuel into the flaming zone of a crown fire is required for combustion of the canopy fuel layer to continue. In this conceptual formulation, the flame front is viewed as stationary with the fuel moving into it (Agee 1996).

Building on the previous work of Thomas et al. (1964) and Thomas (1967), Van Wagner (1977a) proposed that a critical minimum spread rate needed to preserve continuous crowning ($ROS_{critical}$, m/min) could be estimated on the basis of a stand's canopy bulk density (CBD, kg/m³) using the following simplistic equation:

$$ROS_{critical} = 3.0 \div CBD \quad (6)$$

CBD is in turn calculated as follows:

$$CBD = CFL \div CD \quad (7)$$

where CFL is available canopy fuel load (kg/m^2) and CD is the crown depth (m) (i.e., the stand height less the CBH). Dickinson et al. (2009) claimed to have recalibrated the Van Wagner (1977a) model represented by equation (6) on the basis of CFL as opposed to CBD. Cruz and Alexander (2010a) have clearly shown that this modification is unreliable as a means of distinguishing active crown fires from passive crown fires.

According to equation (6), $ROS_{critical}$ increases as the CBD decreases (fig. 9-13). High CBD levels are associated with dense stands and low values with open stands (fig. 9-8). Active crowning is presumably not possible if a fire does not spread rapidly enough following initial crown combustion. Albini (1993) viewed this criterion for active crowning as a “lean flammability limit.” Thus, if a fire’s actual ROS after the initial onset of crowning, which is in turn a function largely of the prevailing windspeed or slope, is less than $ROS_{critical}$, a passive crown fire is expected to occur (fig. 9-5). Some authors have misinterpreted $ROS_{critical}$ to mean the surface as opposed to crown fire spread rate (e.g., Keyes 1996).

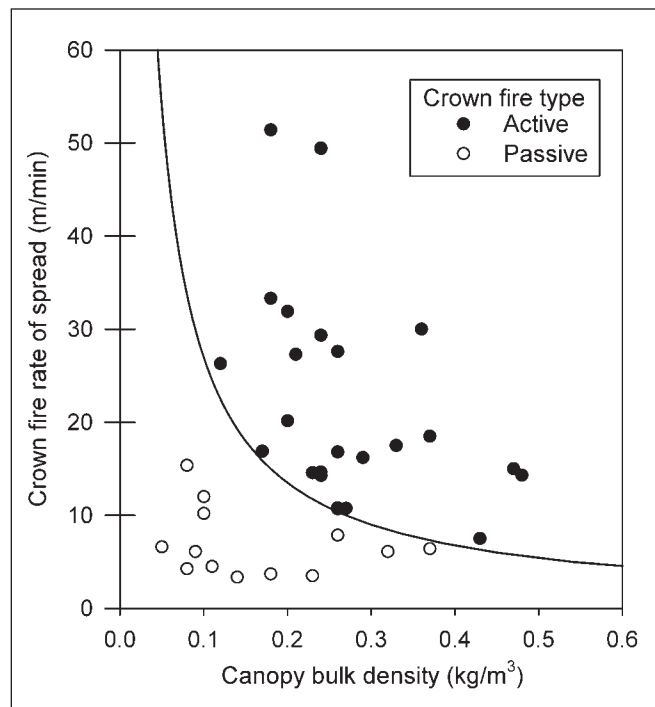

Figure 9-13—Critical minimum spread rate for active crowning in a conifer forest stand as a function of canopy bulk density according to Van Wagner (1977a) in relation to plotted experimental crown fire data (after Cruz and Alexander 2010a).

The 3.0 empirical constant given in equation (6) was derived largely on the basis of a single experimental crown fire in a red pine plantation stand exhibiting a CBD of 0.23 kg/m^3 (Van Wagner 1964). In contrast, Thomas (1967) determined, on the basis of experimental fires conducted in the laboratory in wooden crib fuel beds, that the empirical constant in equation (6) varied from 3.6 to 4.8 as opposed to the value of 3.0 derived by Van Wagner (1977a). The robustness of the value derived by Van Wagner (1977a) for conifer canopies has since been confirmed on the basis of an analysis of a relatively large data set of experimental crown fires (fig. 9-13) in several different conifer forest fuel complexes (Cruz et al. 2005) and a detailed wildfire behavior case study (Alexander 1998). Subsequent analyses have shown that CBD levels of around 0.05 and 0.1 kg/m^3 , corresponding to $R_{critical}$ values of 60 and 30 m/min, respectively, constitute critical thresholds for passive and active crown fire development (Agee 1996, Cruz et al. 2005, Cruz and Alexander 2010).

In Van Wagner’s (1977a) crown fire theories, both passive and active crown fires are dependent on surface fire for their continued existence. Furthermore, it is assumed that the canopy fuel layer is horizontally uniform and continuous for efficient crown-to-crown heat transfer. Admittedly, it does not explicitly account for the spacing between the tree crowns. The extent to which the intercrown distance directly affects active crown fire propagation is presently unknown as this fuel complex characteristic is embedded in the CBD. However, from observational evidence obtained through experimental burning, it appears that active crown fires are able to breach gaps in the forest canopy of 10 to 20 m with ease (Alexander et al. 1991).

Van Wagner’s (1977a) models of crown fire initiation and propagation reveal that some conifer fuel complexes are far more prone to or have a greater propensity for crowning than others simply because of their intrinsic fuel properties. For example, many of the black spruce forest types found in Alaska and the Lake States as well as Canada are notoriously flammable (Archibald et al. 1994, Hardy and Franks 1963, Hirsch et al. 2000, Johnson 1964, Norum 1982), making fire suppression difficult (table 9-1). This occurs as

a result of a combination of low CBH, which typifies this tree species over much of its range, the abundance of ladder or bridge fuels (i.e., bark flakes, lichens, and dead branches on the lower tree boles), low FMC levels, and moderately high CBD values (Barney et al. 1978, Chrosiewicz 1986b, Cronan and Jandt 2008, Dyrness and Norum 1983, Norum and Miller 1984) and perhaps other fuel properties (e.g., cones as firebrand source material, high live-to-dead ratios of available fuel within the tree crowns).

Crown Fire Rate of Spread

Surface fires spreading beneath conifer forest canopies seldom exceed 5 to 10 m/min (Dyrness and Norum 1983, Kiil 1976, Norum 1982, Quintilio et al. 1977) without the onset of crowning in some form or another (fig. 9-10). The exceptions would involve open stands with a low-canopy bulk density (say less than 0.05 kg/m^3) or closed-canopied stands exhibiting a very high canopy base height (perhaps 12 to 15 m or greater), in which case, spread rates might reach as high as 25 m/min with associated fireline intensities of 10,000 kW/m (Graham et al. 2012, National Fire Protection Association 1990). Van Wagner (1977a), for example, conducted one experimental fire in a jack pine stand exhibiting a CBH of 6 m and a CBD of 0.04 kg/m^3 in which the spread rate and fireline intensity reached 15 m/min and 15,800 kW/m, respectively. While the requirement for the initial crown combustion was met ($SFI_{critical} = 2,490 \text{ kW/m}$), environmental conditions were such that an $ROS_{critical}$ of 75 m/min could not be attained, the result being a high-intensity, passive crown fire.

Countryman (1964) described the situation between a “closed” versus “open” fire environment when it comes to a free-burning fire in a conifer forest stand:

A fire burning under a dense timber stand is burning in an environment quite different than that above or outside the stand. Fuel moisture is frequently much higher and wind movement is greatly slowed within the stand. If the fire builds in intensity and breaks out through the crowns of the trees and becomes a

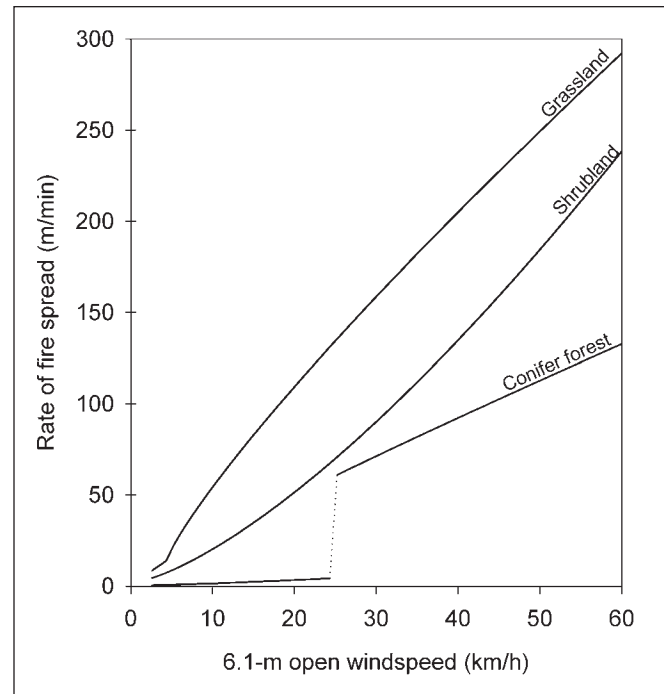

Figure 9-14—Example of rate of fire spread as a function of windspeed for three broad fuel complexes according to the models of Cheney et al. (1998), Rothermel (1972), and Cruz et al. (2004, 2005) for grassland, shrubland, and conifer forest, respectively. More specifically, the Cheney et al. (1998) natural pasture grass fuel type assuming a 100 percent degree of curing and Fire Behavior Fuel Model 4—Chaparral as described by Anderson (1982) with a wind-reduction factor of 0.6 (Albini and Baughman 1979) were used with the Rothermel (1972) model for the shrubland fuel complex. The following fuel complex characteristics were employed in the Cruz et al. (2004, 2005) models for the conifer forest: available surface fuel load, 1.3 kg/m^2 ; canopy base height, 6.0 m; canopy bulk density, 0.23 kg/m^3 ; and stand height, 14 m. The following environmental conditions were held constant: slope steepness, 0 percent; ambient air temperature, $30 \text{ }^\circ\text{C}$; relative humidity, 20 percent; fine dead fuel moisture, 4.8 percent for grassland and 6.0 percent for conifer forest and shrubland; foliar moisture content for conifer forest, 110 percent; and shrub live fuel moisture content, 75 percent. The “kink” in the conifer forest curve represents the point of surface-to-crown fire transition. The Beaufort scale for estimating 6.1-m open windspeeds is presented in table 9-3. A guide to estimating probable maximum 1-min and momentary gust speeds is given in table 9-4.

Table 9-3—Beaufort scale for estimating 6.1-m open windspeeds

Wind class	Windspeed range	Description	Observed wind effects
	(<i>km/h</i>)		
1	< 5	Very light	Smoke rises nearly vertically. Leaves of quaking aspen in constant motion; small branches of bushes sway; slender branchlets and twigs of trees move gently; tall grasses and weeds sway and bend with wind; wind vane barely moves.
2	6 to 11	Light	Trees of pole size in the open sway gently; wind felt distinctly on face; loose scraps of paper move; wind flutters small flag.
3	12 to 19	Gentle breeze	Trees of pole size in the open sway very noticeably; large branches of pole-size trees in the open toss; tops of trees in dense stands sway; wind extends small flag; a few crested waves form on lakes.
4	20 to 29	Moderate breeze	Trees of pole size in the open sway violently; whole trees in dense stands sway noticeably; dust is raised in the road.
5	30 to 39	Fresh	Branchlets are broken from trees; inconvenience is felt walking against wind.
6	40 to 50	Strong	Tree damage increases with occasional breaking of exposed tops and branches; progress impeded when walking against wind; light structural damage to buildings.
7	51 to 61	Moderate gale	Severe damage to tree tops; very difficult to walk into wind; significant structural damage occurs
8	>62	Fresh gale	Surfaced strong Santa Ana; intense stress on all exposed objects, vegetation, buildings; canopy offers virtually no protection; windflow is systematic in disturbing everything in its path.

Source: Adapted from Rothermel 1983.

Table 9-4—Gust estimating table for windspeeds at the 6.1-m open height standard

Standard 10-min average speed		Probable maximum 1-min speed		Probable momentary gust speed			
				Average		Maximum	
<i>mi/h</i>	<i>km/h</i>	<i>mi/h</i>	<i>km/h</i>	<i>mi/h</i>	<i>km/h</i>	<i>mi/h</i>	<i>km/h</i>
1	1.6	3	4.8	6	9.7	9	14.5
2	3.2	5	8.0	8	12.9	12	19.3
3	4.8	6	9.7	11	17.7	15	24.1
4	6.4	8	12.9	13	20.9	17	27.4
5	8.0	9	14.5	15	24.1	18	29.0
6	9.7	10	16.1	16	25.7	20	32.2
7	11.3	11	17.7	17	27.3	21	33.8
8	12.9	12	19.3	19	30.6	23	37.0
9	14.5	13	20.9	20	32.2	24	38.6
10	16.1	14	22.5	22	35.4	26	41.8
11	17.7	15	24.1	23	37.0	27	43.5
12	19.3	17	27.4	25	40.2	29	46.7
13	20.9	18	29.0	26	41.8	30	48.3
14	22.5	19	30.6	28	45.1	32	51.5
15	24.1	20	32.2	29	46.7	33	53.1
16	25.7	21	33.8	30	48.3	35	56.3
17	27.4	22	35.4	32	51.5	36	57.9
18	29.0	23	37.0	33	53.1	38	61.2
19	30.6	24	38.6	34	54.7	39	62.8
20	32.2	25	40.2	35	56.3	40	64.4
21	33.8	26	41.8	37	59.5	42	67.6
22	35.4	27	43.5	38	61.2	43	69.2
23	37.0	28	45.1	39	62.8	44	70.8
24	38.6	29	46.7	40	64.4	46	74.0
25	40.2	30	48.3	41	66.0	47	75.6
26	41.8	31	49.9	43	69.2	49	78.9
27	43.5	32	51.5	44	70.8	50	80.5
28	45.1	33	53.1	45	72.4	51	82.1
29	46.7	34	54.7	46	74.0	53	85.3
30	48.3	35	56.3	47	75.6	54	86.9

Source: Crosby and Chandler 2004.



D. Blasor-Berhardt.

Figure 9-15—Convection column associated with the major run of the Tok River Fire in east-central Alaska on July 1, 1990. This photo was taken from the town of Tok, which was later threatened, 15 to 30 minutes after the lightning strike that started the fire. The forests in the area are dominated by black spruce. The fire would continue to burn throughout the remainder of the summer, eventually covering some 400 000 ha.

crown fire, it then is burning in an open environment and comes under a different set of controls. Fire behavior and characteristics can change radically.

General observations of wildfires and documentation of experimental crown fires indicate that an abrupt transition between surface and crown fire spread regimes and vice versa is far more commonplace than a gradual transition (Alexander and Cruz 2011a, Burrows et al. 1988, Cohen et al. 2006, Fernandes et al. 2004, McArthur et al. 1966, Stocks et al. 2004b, Van Wagner 1964). With the onset of crowning, at a minimum, a fire typically doubles or even triples its spread rate in comparison to its previous state on the ground surface (McArthur 1965). This sudden jump in the fire's rate of spread (fig. 9-14) occurs as a result of (1) the windspeeds just above the tree canopy are 2.5 to 6 times that of the winds experienced near ground level inside the stand, (2) increased efficiency of heat transfer into a tall and porous fuel layer, (3) the enhanced radiant heating owing to the taller and deeper flame fronts, and (4) an increase in spotting density and distance just beyond the fire's leading edge (Anderson 1983, Countryman 1964, Taylor et al. 2004, Van Wagner 1968).

Once crowning has commenced, a fire's forward rate of spread on level terrain is influenced largely by wind velocity (tables 9-3 and 9-4) and to a lesser extent by physical fuel

properties and dryness (fig. 9-14).⁶ If ground and surface fuels are dry and plentiful, and ladder fuels or bridge fuels are abundant, crown fires can still propagate in closed-canopied forests, even if winds are not especially strong (fig. 9-15), although spread rates may not be particularly high (e.g., Hirsch and Flannigan 1990).

Some authors have reported cases in which strong winds have actually limited the degree of crowning rather than increase it even though surface fire intensities were sufficient to induce crowning (e.g., Haftl 1998). For example, during the height of activity associated with the multiple fire situation around Spokane in northeastern Washington on October 16, 1991, with a fine dead fuel moisture of 10 percent and sustained surface winds ranging from 61 to 72 km/h (Alexander and Pearce 1992), the following observation was made regarding ponderosa pine fuel complexes (from National Fire Protection Association 1992):

Typically stands of ponderosa pine contain dead branches extending to the ground. In some cases

⁶ Note that the fire behavior simulation results presented in figures 9-14 and 9-19 (on p. 191) for grassland and conifer stand fuel complexes were derived from empirically based models that have been compared against wildfire observations and shown to be quite reliable. Rothermel's (1972) semiphysical model has, on the basis of comparisons against the experimental fires carried by McCaw (1997), shown to produce creditable predictions for tall shrubland fuel complexes.

these “ladder fuels” enabled the fire to reach the crowns of the 30- to 100-foot [9- to 30-metre] pine trees and would result in the fire spreading at extremely high rates. Unlike other severe wildland fires, however, this “crowning” was fairly limited. The high velocity of the winds did not allow the thermal columns from the fires to reach the crowns.

In addition to the strong winds, the lack of active crowning could have also been due to a combination of light fuel loads (including low available fuel loads resulting from high duff moisture contents), low canopy bulk densities, or high canopy base heights.

Although surface fire rates of spread are greatly increased with increasing windspeed, flame heights are correspondingly reduced (McArthur 1967). This partly explains why some crown fires do not always occur when windspeeds and rates of spread are high (Luke and McArthur 1978). The Burnt Fire that occurred on the Coconino National Forest in northern Arizona as described by Dieterich (1979) constitutes a good case in point. The major run of this fire occurred on November 2, 1973, under the influence of strong surface winds (48 to 64 km/h) but cool air ambient temperatures (10 °C). Surface fuel consumption was estimated to have been low (0.56 kg/m²). Spread rates ranged from 48 to 99 m/min with fireline intensities of 2,325 and 5,250 kW/m (Alexander 1998). Dieterich (1979) summed up the impact on the overstory tree canopy resulting from the Burnt Fire as follows:

Damage from this fast-spreading fire was extremely variable ranging from complete destruction of crown material in patches of saplings and pole timber and an occasional mature tree, to large areas where the only evidence of fire was a blackened littler layer and slight scorch on the lowest portion of the crowns.

Dieterich (1979) noted that much of the ponderosa pine was open-grown with tree crowns extending within 1.2 to 1.5 m of the ground surface.

In addition to being a factor influencing the onset of crowning in conifer forest stands, Van Wagner (1974, 1989, 1993, 1998) also believed that the natural variation in FMC

would presumably have an effect on the rate of spread of a crown fire. Alexander and Cruz (2013c) recently reviewed the related literature on this topic. They concluded that while results from laboratory studies suggest that such an effect should exist, the available experimental field evidence does not support such a conclusion, at least within a normal, live fuel moisture range. None of the existing functions for adjusting crown fire rate of spread for the relative effect of FMC vary widely in their outcomes and relevancy, and none appear suitable for application to dead canopy foliage associated with attack by forest insects and pathogens.

Continuous active crowning generally takes place at spread rates between about 15 and 30 m/min (Van Wagner 1980). Not surprisingly, many fire behavior researchers have over the years suggested a “mile an hour” (i.e., 1.6 km/h or 27 m/min) as a nominal rate of spread for crown fires (e.g., Gisborne 1929, Van Wagner 1968). Alexander and Cruz (2006) from an extensive review of wildfire case studies found an average crown fire rate of spread of 2.3 km/h or 38 m/min.

Crowning wildfires have been known to make major runs of 30 to 65 km over flat and rolling to gently undulating ground during a single burning period or over multiple days (fig. 9-16), as was so vividly demonstrated, for example, on the Rodeo-Chediski Fire in northern Arizona in June 2002 (Paxton 2007) and the Wallow Fire in east-central Arizona in June 2011 (Keller 2011). A wildfire crowning through sand pine forests of the Ocala National Forest in north-central Florida on March 12, 1935 (box 1), initially travelled some 29 km in 3 hours (i.e., about 160 m/min) before a change in wind direction (Custer and Thorsen 1996, Folweiler 1937, Kendrick and Walsh 2007). The Lesser Slave Fire in central Alberta advanced 64 km through a variety of boreal forest fuel types in a period of 10 hours on May 23, 1968 (Alexander 1983, Kiil and Grigel 1969) resulting in an average rate of spread of 107 m/min. During the major run of the Mack Lake Fire that occurred in the Huron National Forest in central Michigan on May 5, 1980, the crown fire rate of spread in jack pine forests peaked, as graphically illustrated by Rothermel (1991a), at nearly 190 m/min during a 15-min interval (Simard et al. 1983). Grass fires have been reported to spread at twice

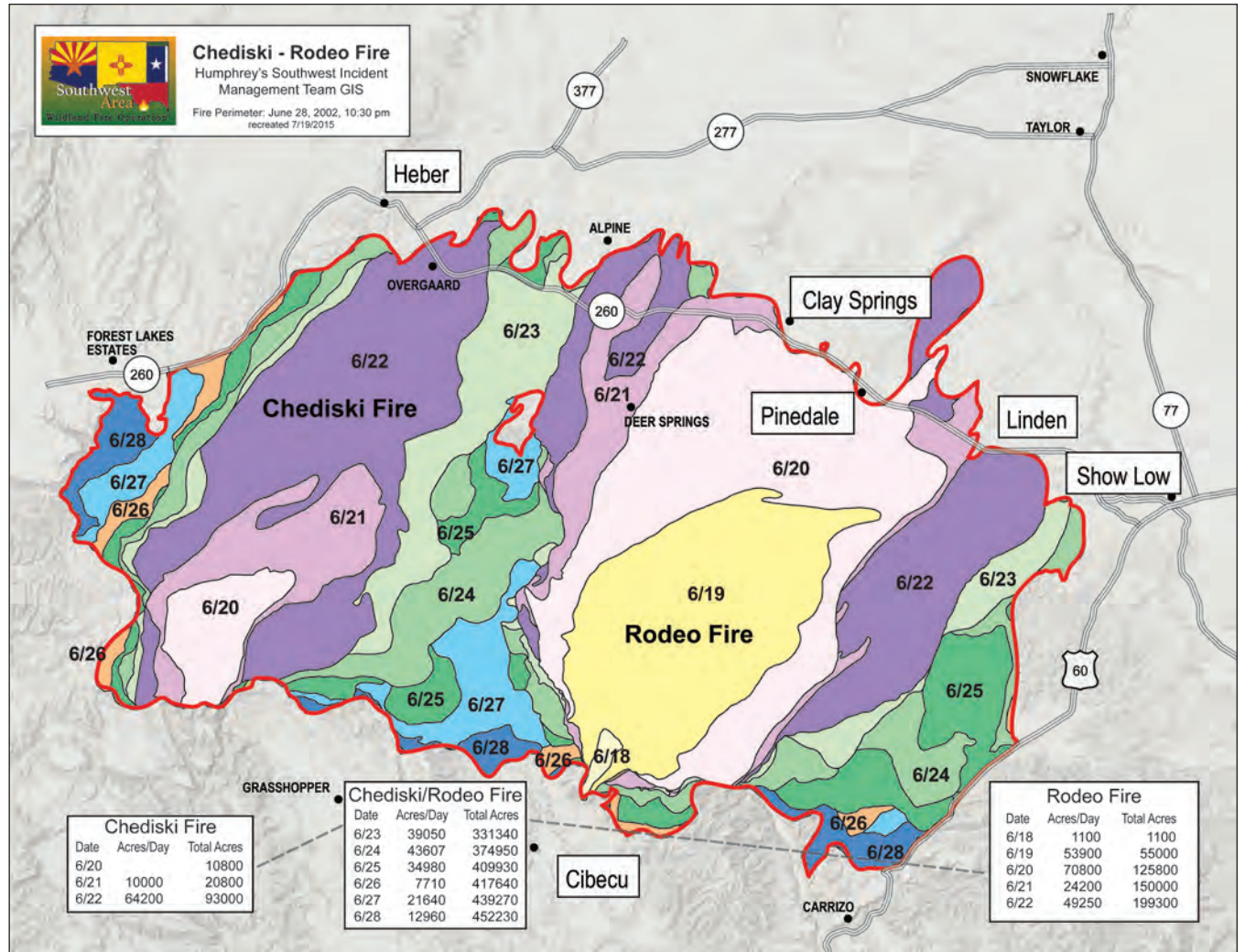

Figure 9-16—Fire progress map for the 2002 Rodeo-Chediski Fire in northern Arizona illustrating the complex growth pattern associated with a long-duration fire. Adapted from http://www.floa.org/rodeo_chediski/rodeo628progress.jpg (31 May 2011).

these rates on level ground (fig. 9-14) and are thus capable of spreading the same distance of crowning forest fires in half the time (Cheney et al. 1998, Cheney and Sullivan 2008).

In some conifer forest fuel types exhibiting discontinuous or very low quantities of surface fuels, surface fire spread is nearly nonexistent even under moderately strong winds. However, once a certain windspeed threshold is reached with respect to a given level of fuel dryness, a dramatic change to crown fire spread suddenly occurs. This type of fire behavior has been observed in pinyon-juniper woodlands of the Western United States (Bruner and Klebenow 1979, Hester 1952) and in the sand pine forests of

Florida (Doren et al. 1987, Hough 1973) for example. The same phenomenon has been observed in certain grassland and shrubland fuel complexes (Burrows et al. 1991, Cheney and Sullivan 2008, Clark 1983, Cruz and Gould 2010, Cruz et al. 2010a, Davis and Dieterich 1976, Lindenmuth and Davis 1973, Racher 2003).

Slope steepness dramatically increases the uphill rate of spread (fig. 9-17) and intensity of wildland fires by exposing the fuel ahead of the advancing flame front to additional convective and radiant heat as illustrated by Luke and McArthur (1978, p. 94). Fires advancing upslope are thus capable of making exceedingly fast runs compared to level

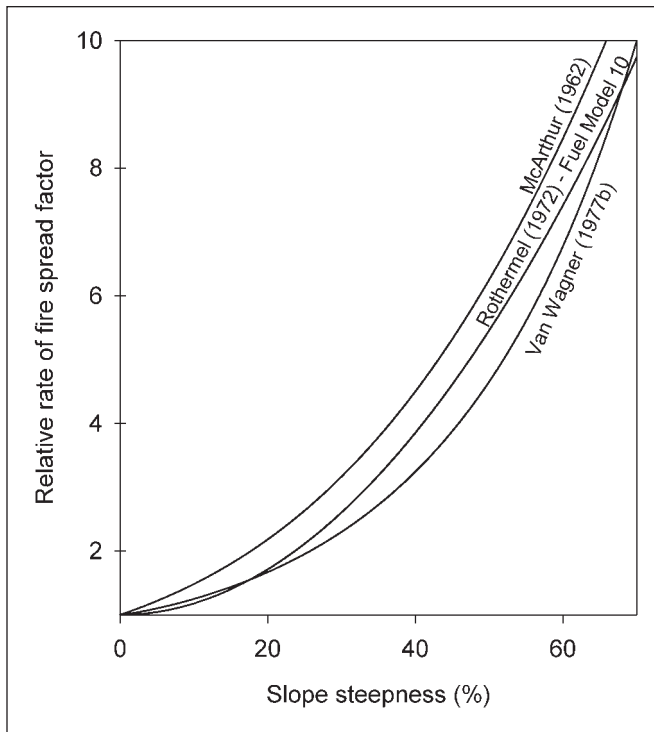

Figure 9-17—The effect of slope steepness on uphill rate of spread of free-burning wildland fires in the absence of wind according to various sources.

topography. For example, one would expect a crown fire burning on a 35 percent slope to spread about 2.5 times as fast as one on level terrain for the same fuel and weather conditions, according to Van Wagner (1977b). The rapid upslope runs that occurred on the 1979 Ship Island Fire in the Salmon National Forest of central Idaho as captured with time-lapse photography and shown in the video *Look*

Up, Look Down, Look Around (National Wildfire Coordinating Group 1993), constitute a good example of such fire behavior.

As slope steepness increases, the flames tend to lean more and more toward the slope surface, gradually becoming attached, the result being a sheet of flame moving roughly parallel to the slope (fig. 9-18). Rothermel (1985) stated that although there is no definitive research on the subject of flame attachment, “it appears from lab work and discussions with users that the flames become attached near 50 percent slope with no prevailing wind.” The critical value will actually differ depending on the prevailing wind strength (Cheney and Sullivan 2008) as well as on the fuel type characteristics. The “power of the slope” in wildland fires was never more evident than with the Dodge escape fire associated with the 1949 Mann Gulch Fire on the Helena National Forest in northwestern Montana (Alexander et al. 2009, Maclean 1992, Rothermel 1993).

With the exception of very long slopes such as found, for example, in the Salmon River country of central Idaho, the rate of advance of wind-driven crown fires in mountainous terrain tends, over the duration of their run, to be well below what would be expected on flat ground, even under critical fire weather conditions (e.g., Goens 1998, Taylor and Williams 1967). As Chandler et al. (1963) noted:

There are strong indications, however, that for periods of 2 to 3 hours, rate of fire spread is greatest in mountainous or broken topography but, for periods of 12 to 24 hours, greatest on flat or gently

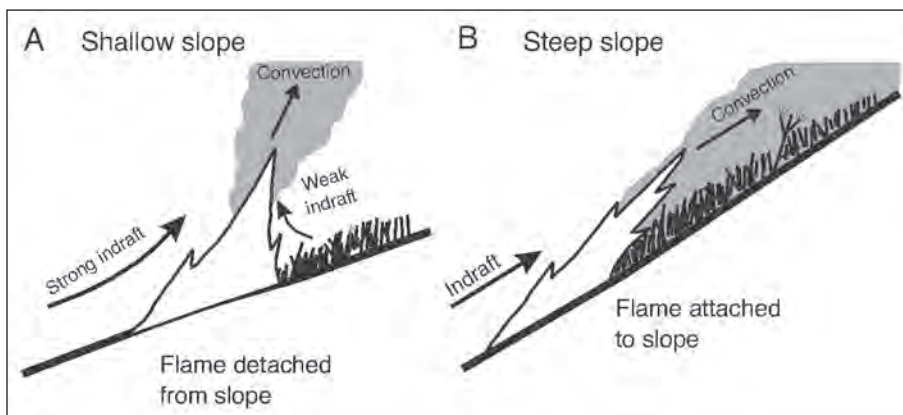

Figure 9-18—Effect of slope steepness on degree of flame attachment and convective heat transfer for shallow (A) and steep (B) sloping terrain (adapted from Rothermel 1985).

rolling topography. The difference probably arises because mountainous country has more steep slopes which cause rapid fire spread, but also more breaks or barriers which retard spread for long periods.

This outcome also undoubtedly occurs as a result of the degree of terrain exposure to the prevailing winds, which limits the full effectiveness of windspeed on fire spread, as well as differences in fuel moisture owing to aspect or slope exposure (Schroeder and Buck 1970). However, when the advancing crown fire front encounters a situation where wind and topography are favourably aligned (Campbell 2005), exceedingly rapid fire growth can occur. Spread rates of about 100 m/min are quite easily possible for a brief period over short distances with only moderately strong winds (e.g., Rothermel and Gorski 1987, Rothermel and Mutch 1986), such as occurred on the 1937 Blackwater Fire on the Shoshone National Forest in northwest Wyoming in which 15 firefighters perished (Brown 1937). Fire spread rates in grassland and shrubland fuel types at even twice this level can easily occur (Butler et al. 1998; Countryman et al. 1968, 1969; Fogarty 1996; Rothermel 1993; Wilson and Davis 1988).

Crown fire runs in mountainous terrain are not limited to just upslope situations. Cases of crown fires burning downslope or cross-slope under the influence of strong winds have occurred in the past (Byram 1954, McAlpine et al. 1991). The major run of the Dude Fire on the Tonto National Forest in northern Arizona on June 26, 1990, that led to the deaths of six firefighters involved downslope and cross-slope spread as a result of the strong downdraft winds associated with the fire's collapsing convection column (Goens and Andrews 1998).

Crown Fire Intensity and Flame Zone Characteristics

When a fire in a conifer forest stand crowns, additional fuel is consumed primarily in the form of needle foliage (Wendel 1960) but also mosses and lichens, bark flakes, and small woody twigs. Empirical data on the latter fuel component are limited to a single study (Stocks et al. 2004b). The additional fuel consumed by a crown fire owing to the canopy fuel involvement generally amounts to 0.5 to 2.0 kg/m²

depending on stand characteristics (i.e., an increase in fuel consumption with respect to fireline intensity of one-quarter to a doubling in the amount). Combined with the increase in rate of fire spread after crowning, fireline intensities can easily quadruple in value within a few seconds (e.g., from 3,000 to 12,000 kW/m) and spotting activity very quickly increases in both density and distance (Albini et al. 2012, Byram 1959b). In such cases, there is little wonder why some fires just seem to literally “blow up” (Burrows 1984, Byram 1954, Gisborne 1929, McArthur et al. 1966).

A fire's flame zone characteristics (i.e., depth, angle, height, and length) are a reflection of its heat or energy-release rate. As the fireline intensity or rate of energy released per unit area of the flame front increases (fig. 9-19A) because of a faster rate of spread and a larger quantity of fuel being volatilized in the flaming front, flame size or volume increases (Albini 1981a, Nelson 1980, Thomas 1963). Fireline intensities of wind-driven crown fires can easily reach 30,000 kW/m (DeCoste et al. 1968, Dieterich 1976, Simard et al. 1983, Wade and Ward 1973) and occasionally exceed 100,000 kW/m for significant periods of time (Anderson 1968, Kiil and Grigel 1969).

The flame depth (D , m) of a spreading wildland fire (fig. 9-4) is a product of its *ROS* and the flame front residence time (t_r , min), which represents the duration that a moving band or zone of continuous flaming combustion persists at or resides over a given location (after Fons et al. 1963):

$$D = ROS \times t_r \quad (8)$$

Flame front residence times are dictated largely by the particle size(s) distribution, load, and compactness of the fuel bed (Burrows 2001, Cheney 1981, Nelson 2003b, Nelson and Adkins 1988).

Flame front residence times for conifer forest fuel types at the ground surface are commonly 30 sec to 1 min (McArthur and Cheney 1966, Taylor et al. 2004) compared to 5 to 10 sec in fully cured grass fuels (Cheney and Sullivan 2008). Assuming $t_r = 0.75$ min (i.e., 45 sec), a surface fire in a conifer forest spreading at 4.0 m/min would thus have flame depth of around 3.0 m according to equation (8). Crown fires are capable of producing very deep flame fronts (fig. 9-19B). The depth of the burning zone in the surface fuels of a crown fire spreading at 60 m/min would, for example, be around

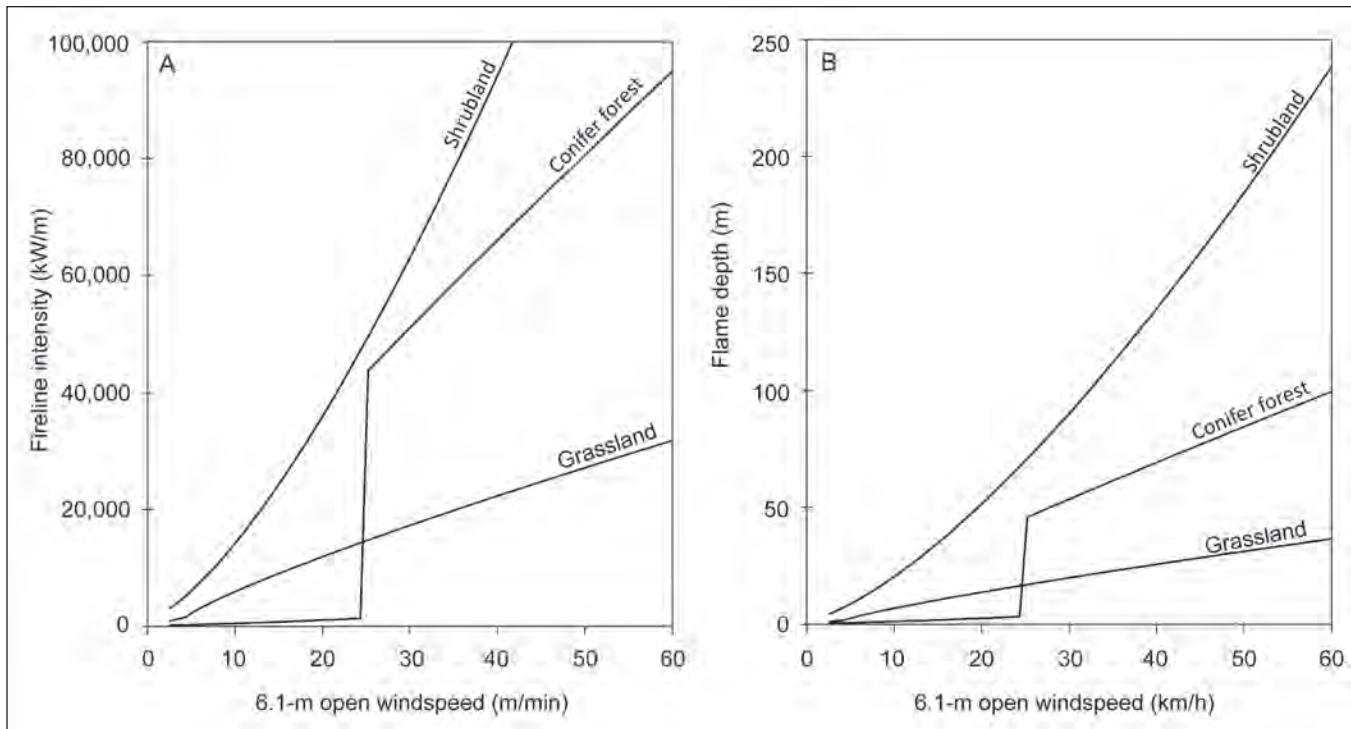

Figure 9-19—Examples of (A) fireline intensity and (B) flame depth as a function of windspeed for three broad fuel complexes according to the models of Cheney et al. (1998), Rothermel (1972), and Cruz et al. (2004, 2005) for grassland, shrubland, and conifer forest, respectively. More specifically, the Cheney et al. (1998) natural pasture grass fuel type assuming a fuel load of 0.35 kg/m^2 and 100 percent degree of curing, and for the shrubland fuel complex, Fire Behavior Fuel Model 4—Chaparral as described by Anderson (1982) with a wind reduction factor of 0.6 (Albini and Baughman 1979) was employed in Rothermel's (1972) model. The following fuel complex characteristics were employed in the Cruz et al. (2004, 2005) models for the conifer forest: available surface fuel load, 1.3 kg/m^2 ; canopy base height, 6.0 m; canopy fuel load, 1.0 kg/m^2 ; canopy bulk density, 0.23 kg/m^3 ; and stand height, 14 m. The following environmental conditions were held constant: slope steepness, 0 percent; ambient air temperature, $30 \text{ }^\circ\text{C}$; relative humidity, 20 percent; fine dead fuel moisture, 4.8 percent for grassland and 6.0 percent for conifer forest and shrubland; foliar moisture content for conifer forest, 110 percent; and shrub live fuel moisture content, 75 percent. The flame front residence times used for estimating flame depths for grassland, shrubland, and conifer forest were assumed to be 7.5, 60, and 45 sec, respectively. The “kink” in the curves associated with the conifer forest represent the point of surface-to-crown fire transition. The Beaufort scale for estimating 6.1-m open windspeeds is presented in table 9-3. A guide to estimating probable maximum 1-min and momentary gust speeds is given in table 9-4.

45 m. The flame depth of a grass fire advancing at this rate would in contrast be only about a tenth of this value (fig. 9-19B). Residence times within the canopy fuel layer of a crown fire are about one-half to one-third those experienced at ground level (Anderson 1968, Despain et al. 1996, Taylor et al. 2004). This is reflected in the gradual convergence of the flaming zone depth with height ending in the flame tip above the tree crowns (fig. 9-20).

The flame front of a crown fire on level ground appears to be nearly vertical. This appearance has led to the popular phrase “wall of flame” when it comes to describing crown fire behavior (fig. 9-20). Typically though, tilt angles are 5 to

20 degrees from the vertical (Albini and Stocks 1986; Van Wagner 1968, 1977a). The fact that the flames of a crown fire stand so erect is a direct result of the powerful buoyancy associated with the large amount of energy released in the flame front (fig. 9-1C). Radiation from the crown fire wall of flame can produce painful burns on exposed skin at more than 100 m from the fire edge (Albini 1984, Butler and Cohen 1998). Such would have been the case during the major run of the 1985 Butte Fire in on the Salmon National Forest in central Idaho had firefighters not had protective fire shelters to avert thermal injuries (Butler and Cohen 1998, Mutch and Rothermel 1986).



M.G. Cruz

Figure 9-20—Flame front of an active crown fire advancing through the jack pine-black spruce fuel type, International Crown Fire Modeling Experiment, Northwest Territories, Canada.

Given the difficulty of gauging the horizontal depth of the burning zone in a crown fire, flame height constitutes a more easily visualized dimension than flame length (fig. 9-21). However, efforts to objectively estimate flame heights of crown fires are complicated by the fact that sudden ignition of unburned gases in the convection column can result in flame flashes that momentarily extend some 100 m or more into the convection column aloft; one such flame flash that extended almost 200 m above the ground was photographically documented by Sutton (1984). Such flashes can easily result in overestimates of average flame heights, which usually range from about 15 to 45 m on high-intensity crown fires (Byram 1959b). Average flame heights of crown fires are thus generally regarded as being about two (fig. 9-1C) to three times the stand height (Alexander 2006, Cruz and Alexander 2010b, Stocks et al. 2004b, Zárate et al. 2008) (fig. 9-20). This is in contrast to wind-driven grass fires where average flame heights seldom exceed 4

m (Cheney and Sullivan 2008). High-intensity wildfires in mature chaparral in turn commonly exhibit flames of 15 m or more (Wilson and Davis 1988).

Byram (1959a) indicated that his flame length-fireline intensity relation represented by equation (2) would underpredict the flame length for “crown fires because much of the fuel is a considerable distance above the ground.” He suggested, on the basis of visual estimates, that “this can be corrected for by adding one-half of the mean canopy height” to the flame length value obtained by equation (2). Alexander (1998) concluded on the basis of some simple calculations using this approach coupled with a review of existing experimental crown fire observations that Byram’s (1959a) approach to estimating crown fire flame lengths would result in underestimates except perhaps at the lower fireline intensity levels (say less than 5,000 kW/m) in short to moderately tall stands.

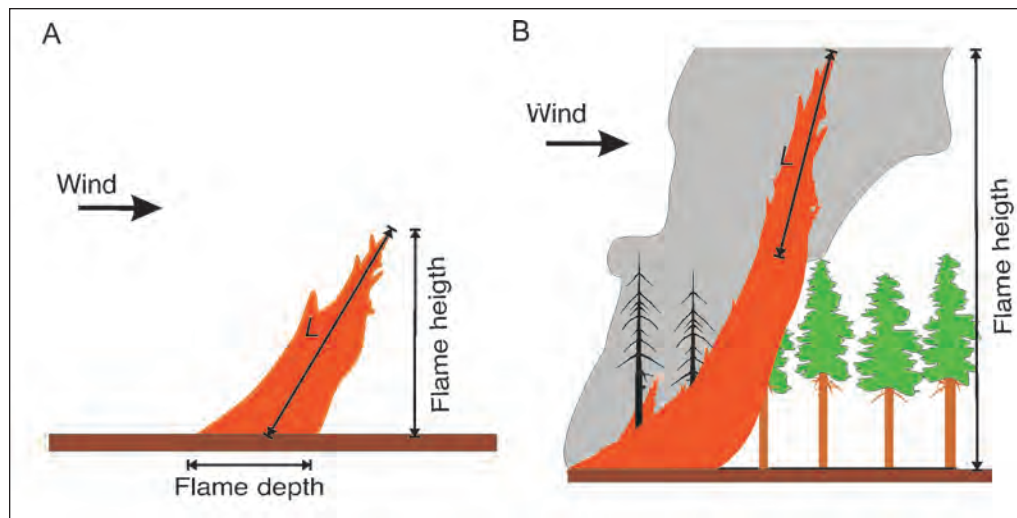

Figure 9-21—Schematic diagram illustrating the distinction between flame length (L) and flame height in a (A) surface fire and (B) crown fire (adapted from Alexander and Cruz 2012b).

Crown Fire Area and Perimeter Growth

For forest fires of today to become large, they typically have to involve some degree of crowning. A common axiom in wildland fire management is that about 95 percent of area burned is generally caused by less than 5 percent of the fires (Kasischke et al. 2006, Stocks et al. 2002, Strauss et al. 1989, USDA Forest Service 1966). When a forest fire at the very minimum doubles its spread rate after the onset of crowning, the area burned for a given period will be at least four times what would have been covered by a surface fire (table 9-5). In other words, the area burned is proportional to the rate of spread increase (following the transition to crowning) to a power of two (McArthur 1965). Thus, if a fire triples its rate of advance after crowning, the area burned will be nine times greater than had it remained as a surface fire (i.e., $3^2 = 9$).

Other than dry and plentiful fuels, the principal ingredients for major crown fire runs in conifer forests are strong, sustained winds coupled with extended horizontal fuel continuity (Campbell 2005, Omi 2005, Rothermel 2000). The Hayman Fire that occurred along the Colorado Front Range, for example, burned close to 25 000 ha during its major run on June 9, 2002, and eventually grew to nearly 56 000 ha towards the end of the month (Graham 2003a, 2003b).

Much of the final area burned (about 45 000 ha) by the 1956 Buckhead Fire that occurred on the Osceola National Forest in north Florida took place during the fire's major run during a 10- to 12-h period on March 24-25 (Newcomb 1957, Storey and Merkel 1960). Under favorable conditions, crown fires on level to gently undulating terrain have been documented to cover in excess of 70 000 ha in a single, 10-hour burning period (Kiil and Grigel 1969) and up to a third that much in mountainous areas (Anderson 1968).

Assuming continuous fuels, including no major barriers to fire spread, and no change in wind and fuel moisture conditions, the forward spread distance of a crown fire can be determined by multiplying its predicted rate of spread by a projected elapsed time (Rothermel 1991b). Provided the wind direction remains relatively constant and the fire environment is otherwise uniform, wind-driven surface and crown fires typically assume a roughly elliptical shape (Alexander 1985, Anderson 1983, Van Wagner 1969) defined by its length-to-breadth ratio ($L:B$) (fig. 9-22), which in turn is a function of windspeed (fig. 9-23). The $L:B$ associated with crown fires generally ranges from a little less than 2.0 (Brotak 1979, Kiil 1975) to around 6.0 (Sando and Haines 1972) and in exceptional cases to a maximum of about 8.0 (Folweiler 1937). Simple estimates of potential

Table 9-5—Semitheoretical comparison of fire behavior in pruned versus unpruned exotic pine plantations under high fire danger conditions as patterned after McArthur’s (1965) fire behavior analyses

Fire description and characteristics	Stand A (pruned to 5 m)	Stand B (unpruned)
Type of fire	Surface	Crown
Head fire rate of spread (m/min)	5	10
Fuel consumed (kg/m ²)	1.8	2.8
Fireline intensity (kW/m)	2700	8400
Flame height (m)	2	12
Elliptical fire area at 1 hr (ha)	4.86	19.4
Elliptical fire perimeter at 1 hr (km)	0.83 ^a	1.65 ^a
Spotting distance (m)	< 200 ^b	Up to 2000 m ^b

^a Theoretically, approximately 9 and 45 percent of the total fire perimeter would have fireline intensities exceeding 2000 kW/m (Catchpole et al. 1992), thereby precluding direct attack by conventional means (Alexander 2000a).

^b After Douglas (1974).

Source: Adapted from Alexander 1992b.

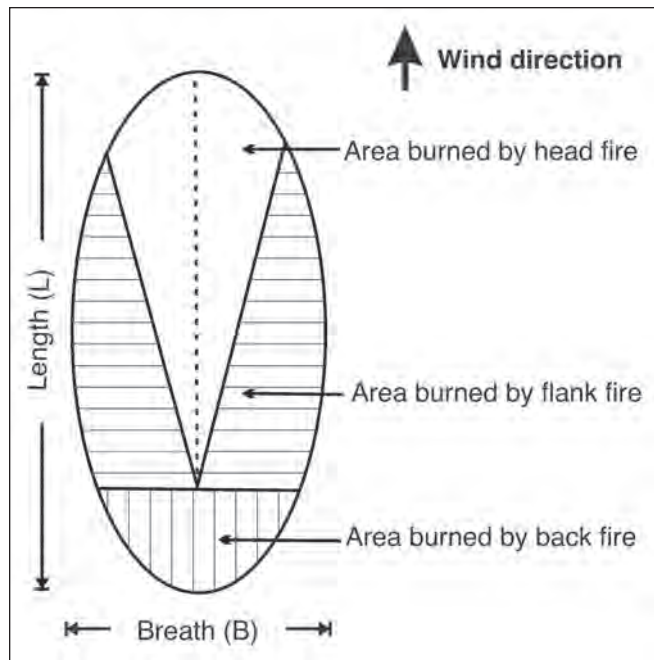

Figure 9-22—Schematic diagram of a simple elliptical fire growth model (after Van Wagner 1969). The point of ignition is at the junction of the four area growth zones.

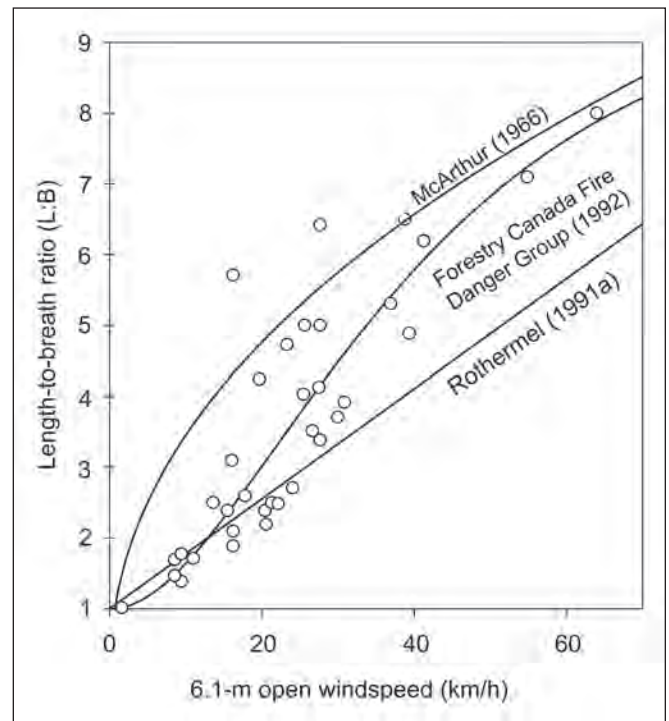

Figure 9-23—Length-to-breadth ratio of elliptical shaped fires on level terrain as a function of windspeed as used in the Canadian Forest Fire Behavior Prediction System (Forestry Canada Fire Danger Group 1992), Rothermel’s (1991a) guide to crown fire behavior, and McArthur’s (1966) model for grass fires in relation to the experimental fire and wildfire observations given in Alexander (1985) and Forestry Canada Fire Danger Group (1992) for various conifer forest fuel types. The Beaufort scale for estimating 6.1-m open windspeeds is presented in table 9-3. A guide to estimating probable maximum 1-min and momentary gust speeds is given in table 9-4.

crown fire size in terms of area burned and perimeter length can be made on the basis of the forward spread distance and L:B (fig. 9-24).

This simplistic picture of fire growth as described here is applicable to cases involving a point source ignition (e.g., an escaped campfire or lightning-fire start), a prescribed fire holdover or escape, or perhaps a breach in an established control line on a wildfire, involving unidirectional winds and is generally limited to a 1- to 8-h projection period. This approach is thus not appropriate to estimating crown fire growth when the perimeter becomes highly irregular in shape with the passage of time as a result of changes in wind direction, fuel types, and terrain characteristics as shown in fig. 9-16 and in the progression maps compiled for the fires in the Greater Yellowstone Area during the 1988 fire season for example (Rothermel et al. 1994) as well as other incidents (e.g., Quintilio et al. 2001, Tymstra et al. 2005).⁷

One particularly dangerous synoptic fire weather situation worth highlighting with respect to crown fire behavior is the case of the dry cold frontal passage (Krumm 1959, Schroeder and Buck 1970). In the Northern Hemisphere, as the cold front passes over an area, winds shift rapidly from southwesterly to the west, then northwest in direction. Windspeeds increase in strength as a front approaches and usually become quite strong and gusty when the front passes over an area. This can result in a long crown fire run in a north-northeast direction followed by a fire's entire right flank crowning in an east-southeast direction at an even greater rate of spread and intensity (DeCoste et al. 1968, Simard et al. 1983, Wade and Ward 1973). In the Southern Hemisphere, the wind and fire spread patterns are similar, though the north and south components are reversed (Cruz et al. 2012b, Keeves and Douglas 1983).

Oscillations in land-sea breezes can also lead to dramatic escalations in high-intensity crown fire behavior and sudden, radical changes in the direction of fire spread,

⁷ Information on similar large fire incidents in the United States is available from the Incident Information System (<http://www.incweb.org/>).

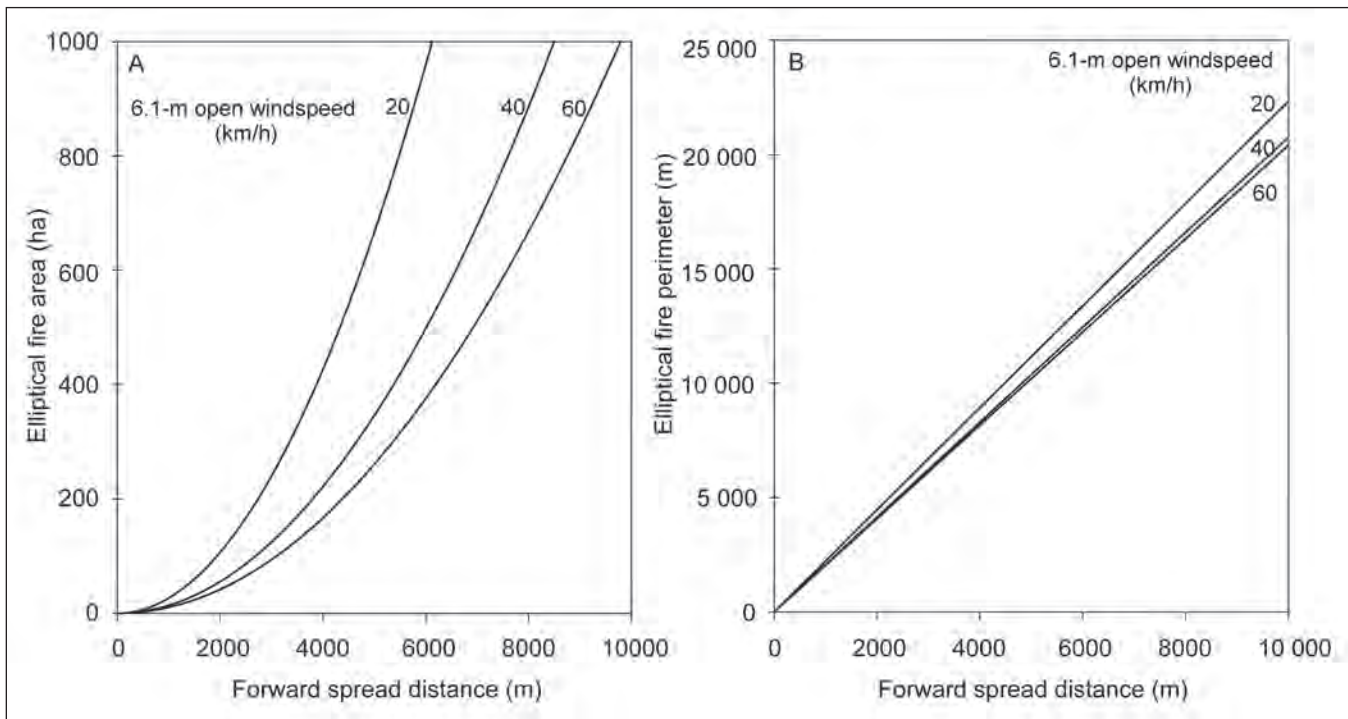

Figure 9-24—Area burned (A) and perimeter length (B) of an elliptical shaped crown fire as a function of forward spread distance and windspeed on level terrain based on the length-to-breadth ratio embedded in the Canadian Forest Fire Behavior Prediction System (Forestry Canada Fire Danger Group 1992). The Beaufort scale for estimating 6.1-m open windspeeds is presented in table 9-3. A guide to estimating probable maximum 1-min and momentary gust speeds is given in table 9-4.

which can in turn threaten the safety of firefighters (Williams 1969). Other mesoscale-related weather phenomena (i.e., weather observations resulting from causes too localized to be identifiable from the basic network observations, yet too widely separated to be reasonably deduced from observations at a single station) such as thunderstorm drafts (Goens and Krumm 2000, Haines 1988) are reviewed in Schroeder and Buck's (1970) seminal work on fire weather meteorology. Chandler (1976) felt that more than half of the fire behavior-related wildland firefighter fatalities in the United States since 1957 were the result of mesoscale phenomena.

Crown Fire Spotting Activity

Rothermel and Andrews (1987) have rightly stated that "Spotting is not restricted to crown fires, but is usually associated with severe fires of some type. It is one of the most intractable problems we face." Spotting or mass ember transport can be an important mechanism determining a crown fire's overall rate of spread under certain conditions (Kerr et al. 1971). Pioneer fire researcher Harry T. Gisborne⁸ gives a vivid account of observing an initiating spot fire that occurred on the Quartz Creek Fire (Gisborne 1927) in Kaniksu National Forest of northern Idaho in 1926:

In my experience on forest fires, I have actually seen only one case of a wind-blown ember falling and causing ignition. This was on the Quartz Creek fire on the Kaniksu in 1926, when a small twig, about one-eighth inch [~3 mm] diameter by one-half inch [~13 mm] long, fell from the smoke cloud above and came to rest on some rotten wood that I was looking at. As I examined the ember, without touching it, I saw that it was still glowing. During the four and a half minutes required to measure the temperature, humidity, and wind, which were 78° [F; 25.6°C], 21% and 5.5 m.p.h. [8.9 km/h] respectively, this ember ignited the rotten wood, which ignited some

dry grass and a minute or two later this spot fire was crowning in a small Douglas-fir.

The general effect of spotting on crown fire rate of spread is determined by the density of ignitions and distances these ignitions occur ahead of the main fire (Alexander and Cruz 2006). These two characteristics are intimately linked, with density typically decreasing with distance from the main advancing flame front.

The effect of spotting on the overall spread and growth of a wildland fire is dependent on topography and fuel distribution. In certain fuel types, the propagation of active crown fires is linked to high-density, short-range spot fires occurring up to 50 m or so ahead of the main advancing flame front followed by their subsequent coalescence. Under such conditions, the overall fire spread is dictated by spotting as well as radiative and convective heat transfer mechanisms associated with the crowning phase (Taylor et al. 2004). In situations involving heterogeneous fuel type distributions and complex topography, spotting will allow the main advancing fire front to quickly bypass areas with low spread potential (e.g., downslope runs, pure hardwood stands in summer, discontinuous fuels) thereby effectively advancing the horizontal extent of the fire's "head" (Sando and Haines 1972). Spotting from crown fires is also effective in breaching major barriers to fire spread, including large water bodies and other nonfuel areas (e.g., rock slides, barren ground). Thus, constructing fuelbreaks comprised of vegetation of low flammability can (Alexander 2010b), depending on their width, be an effective buffer against crown fires (Bickford 1972, Childs 1961, Green 1977) but only up to a point (Amiro et al. 2001).

When fire environment conditions are uniform and winds aloft are favorable, spotting can contribute to the overall spread and growth of crown fires provided the spot fires are able to burn independently of the main advancing fire front. In most high-intensity wildfires that involve crowning, spot fires originating out ahead of the advancing flame front are typically overrun and thus incorporated into the larger fire perimeter before they are able to develop and spread independently, or otherwise be influenced by the main fire (e.g., in-draft winds). For a crown fire spreading

⁸ Gisborne, H.T. 1934. Unpublished memo dated September 11, 1934. On file with: H.T. Gisborne Papers, Archives and Special Collections, Maureen and Mike Mansfield Library, University of Montana, Missoula, MT.

at a rate of 50 m/min or 3 km/h and burning under homogeneous fuel, weather, and topographic conditions, spotting distances would have to exceed, depending on the ignition delay, which can be as much as 10 minutes (Hirsch et al. 1979), about 500 to 700 m (fig. 9-25) to have the potential to increase a fire's overall rate of spread through a "leap frog" type of effect (Alexander and Cruz 2006). If there are sufficient spot fires at or just beyond this distance and that can rapidly coalesce, this "mass ignition" effect will temporarily lead to the formation of pseudo flame fronts with greatly increased flame heights (Wade and Ward 1973).

Spotting distances of up to about 2 km are commonly observed on wind-driven crown fires in conifer forests (Kiil et al. 1977, Luke and McArthur 1978), but spotting distances close to 5 km have been documented as well (Haines and Smith 1987, Jemison 1932). Spot fire distances of 6 to 10 km were reported to have occurred in the Northern Rocky Mountains during the 1910 and 1934 fire seasons (Gisborne 1935, Koch 1942). This is similar to what has been reported

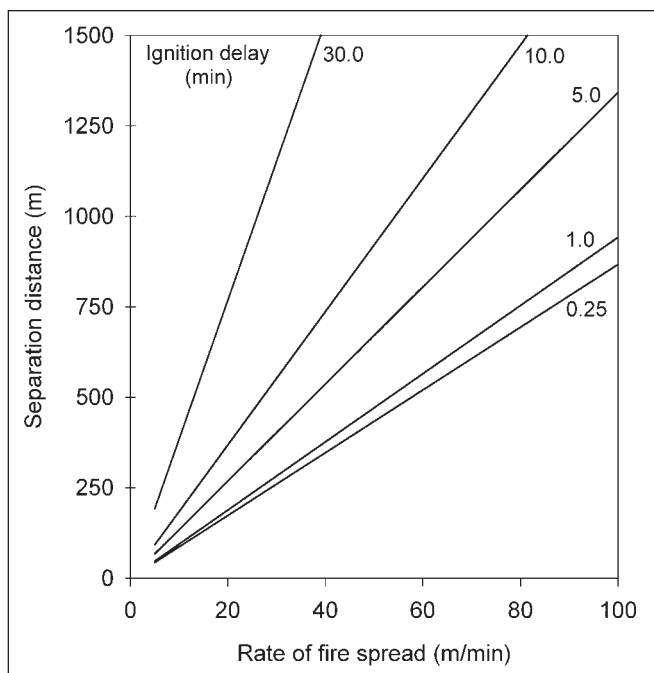

Figure 9-25—Minimum separation distance required for a newly ignited spot fire to avoid being overrun by the main flame front of an advancing crown as a function of rate of spread and ignition delay (adapted from Alexander and Cruz 2006). Ignition delay represents the elapsed time between a firebrand alighting, subsequent ignition, and the onset of fire spread.

in chaparral shrubfields of southern California (Countryman 1974).

The occurrence of spotting distances greater than 5 km requires a specific combination of convection column strength and vertical wind profile. For a viable firebrand to travel such distances, a large amount of energy needs to be released (associated with the postfrontal combustion of large fuels) to transport the firebrands at significant heights (Rothermel 1994). Spotting distances of this magnitude are likely to be associated with isolated peaks of fire intensity, such as those occurring in an upslope run, that will inject large quantities of firebrands in the plume. An atmospheric profile with very strong winds aloft is also necessary to considerably tilt the convection column and allow for significant drift of the firebrand after it leaves the plume (Kerr et al. 1971). Under exceptional circumstances, spotting distances greater than 10 km have been described. Especially noteworthy are the 16- to 19-km spot fire distances associated with the 1967 Sundance Fire in northern Idaho (Anderson 1968, Rothermel 1968), which were quite possibly caused by massive fire-induced vortices (Berlad and Lee 1968). Similar distances are reported to have occurred in Monterey or radiata pine plantations during the major run of the 1983 Mount Muirhead Fire in South Australia (Keeves and Douglas 1983, O'Connor and O'Connor 1993). However, this pales in comparison to the long-range spot fires of up to 30 km or more observed in the native eucalypt forests of Australia (Cruz et al. 2012b, McArthur 1967).

Spotting can be one of the primary mechanisms contributing to the forward spread and growth of fires in certain conifer forest fuel types such as those found in the high-elevation forests of the Rocky Mountains and Pacific Northwest. When fire danger and fire weather conditions are not particularly conducive to active crowning until later in the fire season (Williams and Rothermel 1992), fires in these high-elevation fuel types tend to smolder in deep organic layers, moving very slowly until they encounter ladder fuels favorable for vertical fire development, thereby throwing numerous embers ahead of the main advancing fire front that leads to an outbreak of spot fires (Beighley and Bishop 1990). These newly developed spot fires continue to smolder until the process is repeated.

Models, Systems, and Other Decision Aids for Predicting Crown Fire Behavior

Models for predicting various aspects of wildland fire behavior, including crowning, take various forms. The two primary types are empirical and theoretical or physical (Pastor et al. 2003; Sullivan 2009b, 2009c; Weber 1991). Hybrids involving each type also exist.

Fire behavior models and related decision support systems should be sensitive to those parameters known to affect fire behavior, such as variations in live and dead fuel moistures, windspeed, and slope steepness, amongst others. As Kessell et al. (1980) pointed out over 35 years ago, models “are only as good as the data, understanding, assumptions, and mathematics that go into their construction.” If the input data are not known accurately enough, model output may be significantly in error (Albini 1976b, Alexander and Cruz 2013b). Reeves et al. (2009) have, for example, recently shown the difficulty of obtaining accurate estimates of CBH and CBD with LANDFIRE for assessing and predicting crown fire behavior. Hopefully, advances in remote sensing technology will ultimately lead to improvements in this regard (Erdody and Moskal 2010, Kramer et al. 2011, Skowronski et al. 2011).

Rothermel Guide to Predicting Size and Behavior of Crown Fires

Rothermel (1972) developed a model for predicting surface fire rate of spread and intensity that still forms the basis for the majority of guides and computerized decision support systems for predicting fire behavior in use today in the United States (Andrews and Queen 2001), including the National Fire-Danger Rating System (NFDRS) (Burgan 1988; Deeming et al. 1972, 1977). In commenting on the 1972 version of the NFDRS, McArthur (1977) had the following to say:

... it only considers an ‘initiating fire’. This is defined as a fire which is not behaving erratically and is spreading without spotting through fuels which are continuous with the ground (no crowning). ... the ‘state of the art’ cannot yet consider fires

which exhibit erratic behaviour other than to show that extreme behaviour is correlated with increasing fire danger.

After forty years of research into fire weather and fire behaviour, it is a shocking admission of the inadequacy of the research program if we must eliminate that segment of the fire danger/fire behaviour spectrum which includes all major fires which probably account for around 90-95 per cent of the fire danger in a severe fire season.

The initial field application of Rothermel’s (1972) model involved 13 stylized or static fuel models⁹ (Albini 1976b, Anderson 1982), which was later followed up with custom fuel models (Burgan 1987, Burgan and Rothermel 1984). There are now 40 standard fuel models (Scott 2007, Scott and Burgan 2005). Methods exist for adjusting the 6.1-m open windspeeds (Crosby and Chandler 2004) to a midflame height as required by the Rothermel (1972) model (Albini and Baughman 1979, Andrews 2012). Procedures also exist for estimating dead and live fuel moistures for use with the model (Rothermel 1983, Rothermel et al. 1986).

While favorable evaluations of observed versus predicted rate of fire spread have been obtained with the Rothermel (1972) model in some surface fuelbeds (e.g., Hough and Albini 1978, Norum 1982, Rothermel and Reinhardt 1983), he acknowledged early on that his model was not applicable to predicting the behavior of crown fires because the nature and mechanisms of heat transfer between the two spread regimes were quite different. In the mid to late 1970s, the general guidance to gauging whether crowning was possible or not was to use the predicted surface fireline intensity or flame length as shown in table 9-6 for example and in other guides (Albini 1976b, Hough and Albini 1978). There was no method at that time for predicting the spread rate or forward spread distance of crown fires, but by the early 1980s, the suggestion was being made to assume that crown fire rate of spread would be two to

⁹ A “fuel model” is a simulated fuel complex for which all fuel descriptors required for the solution of Rothermel’s (1972) mathematical rate of spread model have been specified (Deeming and Brown 1975).

Table 9-6—Fire suppression interpretations of flame length and fireline intensity

Flame length ^a <i>m</i>	Fireline intensity <i>kW/m</i>	Fire suppression interpretations
< 1.2	< 346	Fire can generally be attacked at the head or flanks by persons using handtools. Handline should hold the fire.
1.2 to 2.4	346 to 1,730	Fires are too intense for direct attack on the head by persons using handtools. Handline cannot be relied on to hold fire. Equipment such as plows, dozers, pumps, and retardant aircraft can be effective.
2.4 to 3.4	1,730 to 3,459	Fires may present serious control problems—torching out, crowning, and spotting. Control efforts at the fire head will probably be ineffective.
> 3.4	> 3,459	Crowning, spotting, and major fire runs are probable. Control efforts at head of fire are ineffective.

^a Based on equation (2).

Source: Adapted from Burgan 1979.

four times that of the predicted surface fire rate of spread of Anderson's (1982) Fire Behavior Fuel Model 10 (Rothermel 1983, Rothermel and Mutch 1986).

Rothermel (1983) did include a graph similar to figure 9-11 in his "how to" manual that was prepared much earlier and eventually published separately by Alexander (1988), which also included tables for estimating the critical surface fire intensity required for the onset of crowning as a function of CBH and FMC. These tables were eventually included in a fire behavior field reference (National Wildfire Coordinating Group 1992).

The 1988 fires in the Great Yellowstone Area are generally regarded as the impetus for developing a more robust method of predicting crown fire behavior in conifer forests (Alexander 2009a, Rothermel 1991c), although such a general need had been recognized for many years (e.g., Alexander and Andrews 1989, Buck 1941, USDA FS 1980). Rothermel (1991a) produced such a guide for the northern Rocky Mountains or mountainous areas with similar fuels and climate using currently available information (box 7), including the method of estimating fine dead fuel moisture content (table 9-7) given in Rothermel (1983). The core component of his method or approach was a simple correlation (i.e., a 3.34 multiplier as opposed to 2.0 to 4.0 as suggested earlier) derived from eight wildfire observations of crown fire rate of spread and the corresponding predictions from

his surface fire rate of spread model (fig. 9-26). Rothermel (1991a) also included an adjustment factor (1.7) for estimating the near-maximum crown fire rate of spread associated with upslope runs or sudden surges in crown fire activity but not as a general adjustment factor as Scott (2006) has suggested (Cruz and Alexander 2010).

Rothermel (1991a) emphasized that his statistical model for predicting the spread rate of wind-driven crown fires was a first approximation and that more research was needed to strengthen the analysis. At the time, he did not explicitly include any specific criteria for determining the onset of crowning other than in the most general terms (e.g., examine the fire weather forecast).

Rothermel (1991a) considered his predictive methods were not applicable to plume-dominated or convection-dominated crown fires (Byram 1959b) although Goens and Andrews (1998) applied Rothermel's methods in their post-fire analysis of the 1990 Dude Fire. However, he did end up incorporating Byram's (1959b) ratio of the power of the fire versus power of the wind concepts (Nelson 1993a, 1993b) into his guide so as to distinguish the conditions favorable for plume-dominated crown fires as opposed to wind-driven crown fires (Rothermel 1991a). Neither Byram's (1959b) criteria nor Rothermel's (1991a, 1991c) adaptation of Byram's criteria using surface winds alone have been evaluated for their robustness.

Box 7:

Summary of Major Assumptions Associated With Rothermel’s (1991a) Guide to Predicting Crown Fire Behavior

- These methods are designed to provide a first approximation of the expected behavior of a running crown fire.
- Applicable to the northern Rocky Mountains or mountainous areas with similar fuels and climate.
- The methods are designed to predict the rate of spread and other behavior features of a wind-driven crown fire and help identify the onset of a plume-dominated fire.
- Rate of spread predictions were derived from a small number (8) of fires; prediction relies on the correlation of these fires to predictions of rate of spread using the firespread model of Rothermel (1972) and Fuel Model 10 (Anderson 1982).
- The heat pulse associated with the development of the convection column can be interpreted from the short-term surge of energy predicted by Albini’s (1976a) burnout model.
- Thomas’ (1963) flame length model represents crown fire flames.
- The wind can be represented by using the upper end of the forecast windspeed at the 6.1-m level.
- The moisture of fuels, live and dead, can be represented by five seasonal groups.
- The period of a crown fire run can be estimated.
- The area and perimeter of a fire can be represented by a simple ellipse.
- The effect of firebrands on spreading the fire is accounted for in the correlation of spread to actual fires.
- The surging and stalling of a fire as it climbs and descends slopes can be averaged by assuming zero slope.
- The maximum spread rate can be estimated by using the maximum slope and correlation to maximum observed spread rates during the run of actual fires.

- The range in fire behavior can be reasonably represented by 75 percent confidence limits about the average rate-of-spread estimate.
- Standard fuel models, with addition of large fuels in some cases, can adequately describe the energy release of the surface fuels.
- The energy available from the overstory can be estimated by the crown needle load.
- The effect of additional heat from an understory of reproduction can be assumed to be some fraction of the overstory.
- The burning of decayed logs will increase the heat per-unit area significantly, and this additional heat will have an upper limit approximated by Fuel Model 12.

Table 9-7—Predicted fine dead fuel moisture (FDFM)^a content as a function of ambient air temperature and relative humidity and assuming >50 percent shading at between 1200 to 1600 hours during May through July

Relative humidity	Air temperature Degrees Celsius				
	0 to 9	10 to 20	21 to 31	32 to 42	> 43
	<i>Percent</i>				
0 to 4	4	4	4	4	4
5 to 9	5	5	4	4	4
10 to 14	5	5	5	5	5
15 to 19	6	6	5	5	5
20 to 24	7	7	6	6	6
25 to 29	8	8	7	7	7
30 to 34	8	8	8	7	7
35 to 39	9	9	8	8	8
40 to 44	10	9	9	9	9
45 to 49	10	10	10	10	10
50 to 54	10	10	10	10	10
55 to 59	11	11	11	11	11
60 to 64	12	11	11	11	11
65 to 69	12	12	11	11	11
70 to 74	13	12	12	12	12
75 to 79	14	13	13	13	13

^a The FDFM values are used in the Rothermel (1991a) crown fire rate of spread model and in the Cruz et al. (2004, 2005) models for predicting crown fire occurrence and crown fire rate of spread.

Source: Adapted from Rothermel 1983.

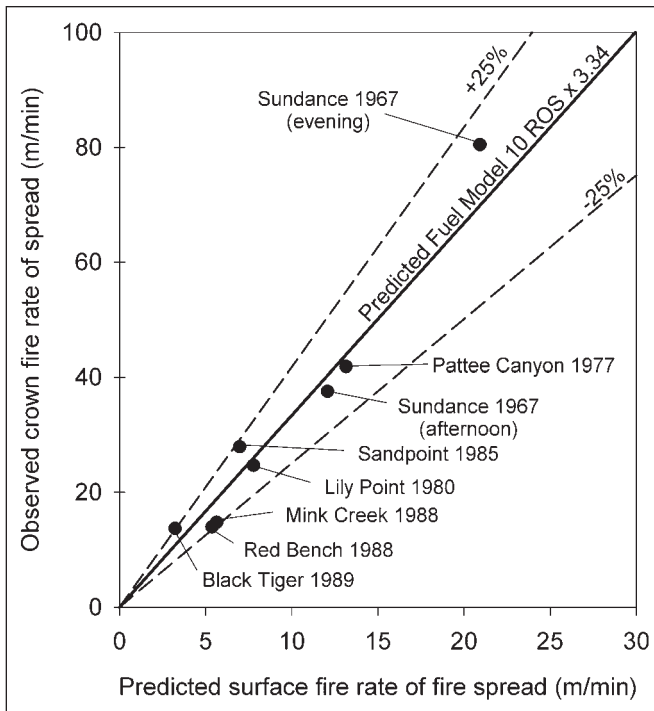

Figure 9-26—Correlation between observed crown fire rate of spread associated with eight Western U.S. wildfires and the Rothermel (1972) predicted surface fire rate of spread using Anderson’s (1982) Fire Behavior Fuel Model 10–Timber (litter and understory) (adapted from Rothermel 1991b).

Rothermel (1991a) suggested using the flame length–fireline intensity relation of Thomas (1963) for predicting the flame lengths of crown fires (fig. 9-27). However, neither his suggestion nor the approach of others seems to work consistently well based on comparisons against data from experimental crown fires (Alexander 1998, 2006). Furthermore, his model for predicting the L:B of crown fires from windspeed, based on the work of Anderson (1983) and Andrews (1986), does not appear to produce realistic results in light of observational evidence (fig. 9-23).

U.S. Fire Modeling Systems

Since the late 1990s, a number of existing and newly developed decision support systems have either separately implemented or linked Rothermel’s (1972, 1991a) surface and crown fire rate of spread models with Van Wagner’s (1977a, 1989, 1993) crown fire transition and propagation criteria. These include both stand- and landscape-scale fire modeling systems:

- BehavePlus (Andrews et al. 2008)
- FARSITE (Finney 2004)
- NEXUS (Scott 1999, Scott and Reinhardt 2001)
- Fire and Fuels Extension to the Forest Vegetation Simulator (FFE-FVS) (Reinhardt and Crookston 2003)
- Fuel Management Analyst (FMA) Plus (Carlton 2005)
- FlamMap (Finney 2006)

Comparisons of these systems are covered in Andrews (2007) and McHugh (2006). To the above list, we can also add two new additional geographic information system-based decision support systems, namely ArcFuels (Ager et al. 2011) and the Wildland Fire Decision Support System (WFDSS) (Noonan-Wright et al. 2011, Pence and Zimmerman 2011).

These fire modeling systems are extensively used for fire operations, planning, and research (Andrews and Queen 2001). McHugh (2006) and Andrews (2007, 2010) provided excellent overviews on the applications of most of these systems to wildland fire management and science. Stratton (2006) in turn provided additional guidance on their use. Each system outputs numerous predictions of fire behavior characteristics and fire effects, including those associated with crowning in conifer forests, although each system has subtle differences in the manner in which they have linked Rothermel’s models with those of Van Wagner (Scott 2006, Stratton 2009) as illustrated in figure 9-28 for the BehavePlus system. There has been no field validation of the crown fire component of these modeling systems.

In spite of the popularity of these fire modeling systems over the years, there appear to be some user-oriented problems. Varner and Keyes (2009) have, for example, identified several commonly encountered errors in regards to modeling inputs involved in simulations of fire behavior potential for research purposes, that may also be applicable to fire operations and planning. These include live and dead fuel moisture estimation, wind adjustment factors, fuel load estimates, fuel model selection, fuel decomposition rates, and fuel bed patchiness. Varner and Keyes (2009) suggested that the errors “can often be tied to unsupported

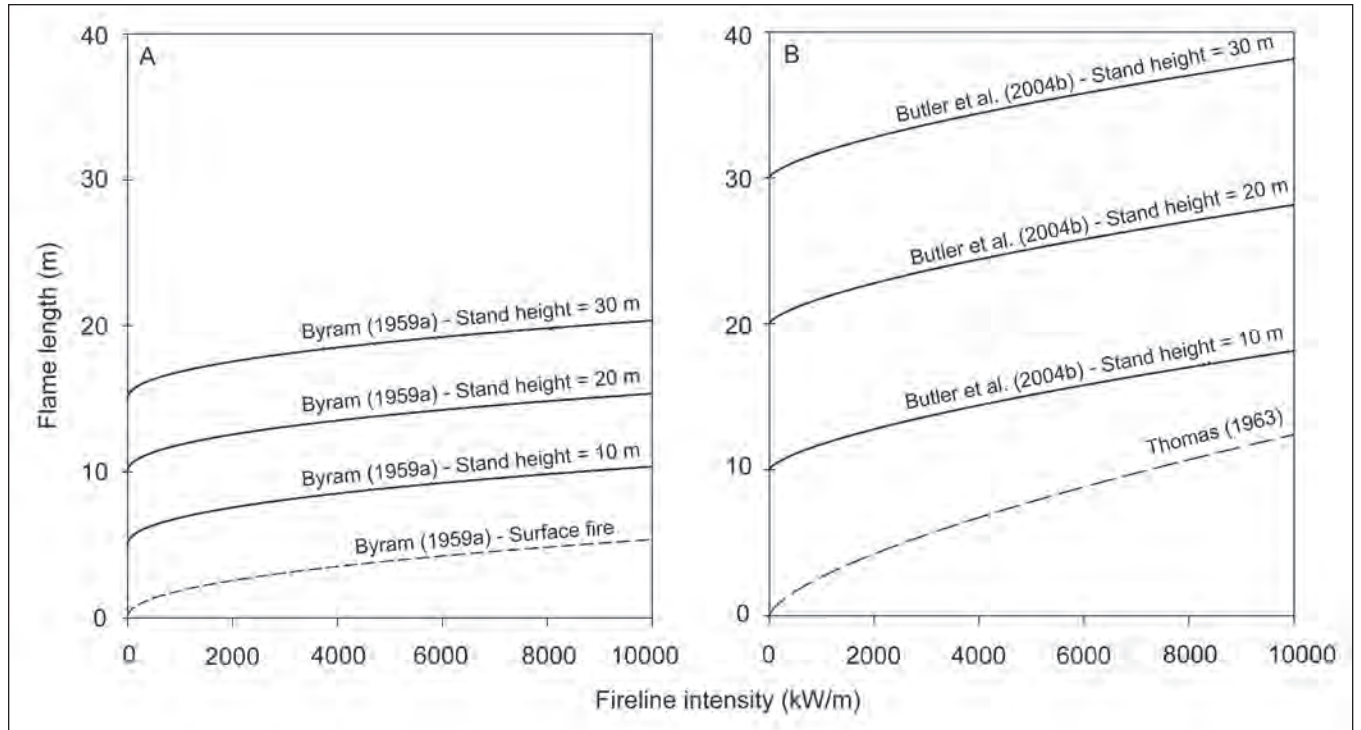

Figure 9-27—Predictions of crown fire flame lengths as a function of fireline intensity and stand height based on (A) Byram's (1959a) model compared to (B) the model of Butler et al. (2004b). Predictions of surface fire flame length using Byram's (1959a) model is shown for comparative purposes as well along with the model of Thomas (1963) based on Rothermel's (1991a) suggestion.

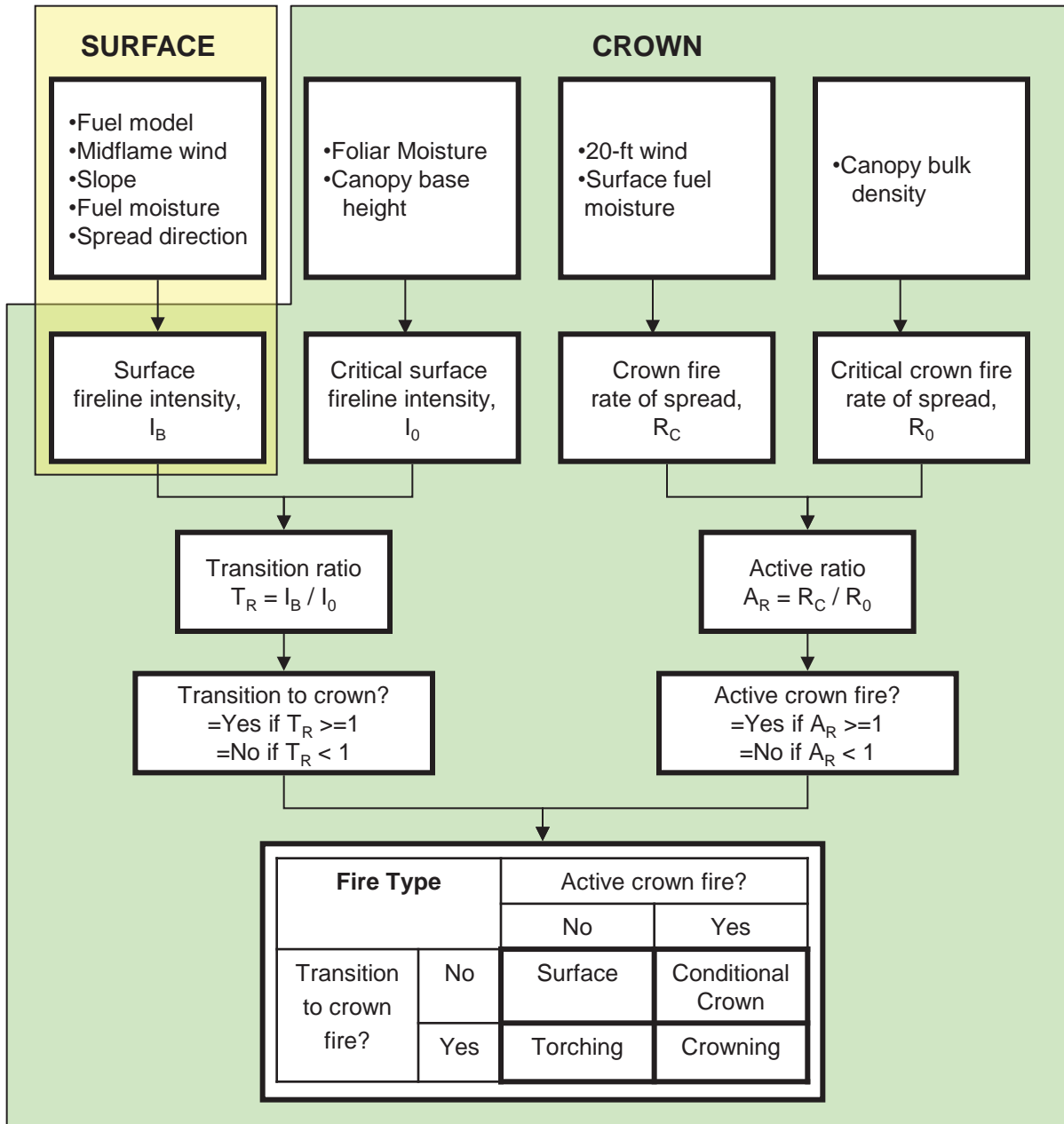

Figure 9-28—Information flow for the CROWN module in the BehavePlus fire behavior modeling system (from Andrews 2007).

assumptions about actual conditions and over reliance on default values.”

A recent review of the use of many of the aforementioned fire modeling systems in several simulation studies examining fuel treatment effectiveness revealed that many users are unaware of a significant underprediction bias that exists within these systems when it comes to assessing potential crown fire behavior in conifer forests of western North America (Cruz and Alexander 2010a). The principal sources of this underprediction bias include (1) incompatible model linkages (fig. 9-29), (2) use of surface and crown fire rate of spread models that have inherent underprediction biases themselves (figs. 9-30, 9-31A, and fig. 9-31B), and (3) a reduction in crown fire rate of spread based on the use of unsubstantiated crown fraction burned (CFB) functions (fig. 9-32).¹⁰ The CFB is a measure of the degree of crown fuel consumption expressed as a percentage of the total number of tree crowns and as such constitutes an indication of the probable type of fire activity to be expressed over a burned area for fuel types that are susceptible to crowning (Poulin et al. 1994). The use of uncalibrated custom fuel models to represent surface fuel beds (Cruz and Fernandes 2008) was also identified as a fourth potential source of bias. Ager et al. (2011) stated that such limitations “are well known by the user community” but offer no evidence for this claim.

The underprediction tendency with the Rothermel (1991a) model was found to occur as well with the crown fire rate of spread model (Schaaf et al. 2007) of the Fuel Characteristic Classification System (FCCS). (Ottmar et al. 2007). Parresol et al. (2012) have indicated that the reformulation of the Rothermel (1972) surface fire rate of spread model by Sandberg et al. (2007) as incorporated in the FCCS has overcome the underprediction tendency observed in model predictions. However, no empirical evidence has been offered to date to substantiate this claim.

¹⁰ Note that Van Wagner’s (1993) CFB function failed to produce values greater than 0.9 (i.e., threshold continuous crown fire development) for 8 of the 11 experimental fires that Stocks (1987b) identified as displaying active or continuous crowning “with flame heights reaching 20 m or twice the average stand height” as photographically illustrated in Stocks and Hartley (1995) for three of the crown fires. The mean and range in CFB values were 0.64 and 0.30 to 0.96, respectively. For further information on the CFB concept, see Alexander and Cruz (2010a, pp. 387–389).

The Cruz and Alexander (2010a) review also highlighted some issues with the manner in which users have been handling certain inputs in their crown fire modeling (i.e., foliar moisture content, canopy base height, and canopy bulk density) and some perceived shortcomings of the two windspeed-based crown fire hazard indexes originally developed by Scott (1998a, 1998d) and expanded upon later by Scott and Reinhardt (2001). Many authors were found to be using the National Fire Danger Rating System (Deeming et al. 1977), which generated dead fuel moisture contents rather than using the procedures given in Rothermel (1983) as used by Rothermel (1991a) in the development of his crown fire rate of spread model. In spite of all the limitations identified by Cruz and Alexander (2010a), studies similar to those reviewed by Cruz and Alexander (2010a) continue to be published (e.g., Honig and Fulé 2012, Johnson et al. 2011, Stephens et al. 2012, Van de Water and North 2011). Furthermore, several authors have recently begun to apply the fire modeling systems to lodgepole pine stands attacked by the mountain pine beetle (Klutsch et al. 2011, Schoennagel et al. 2012, Simard et al. 2011), a situation that they were clearly never designed for (Jenkins et al. 2012; Page et al. 2014).

Canadian Forest Fire Behavior Prediction System

Do alternative methods exist for predicting crown fire behavior in certain regions of the United States? The Canadian Forest Fire Behavior Prediction (FBP) System (Forestry Canada Fire Danger Group 1992, Taylor et al. 1997, Wotton et al. 2009) constitutes one such possibility, at least for certain regions of the United States possessing fuel complexes structurally similar to those found in adjacent areas of Canada. The FBP System is a module of the larger Canadian Forest Fire Danger Rating System (CFFDRS) (Lawson and Armitage 2008, Taylor and Alexander 2006), which also includes the Canadian Forest Fire Weather Index (FWI) System (Van Wagner 1987). Work began on the development of the FBP System in the early 1980s (Lawson et al. 1985). Some states have adopted all or part of the CFFDRS such as Alaska (Alexander and Cole 1995, 2001; Cole and Alexander 1995a, 1995b), Minnesota, Michigan, and Wisconsin as well as some foreign countries such as

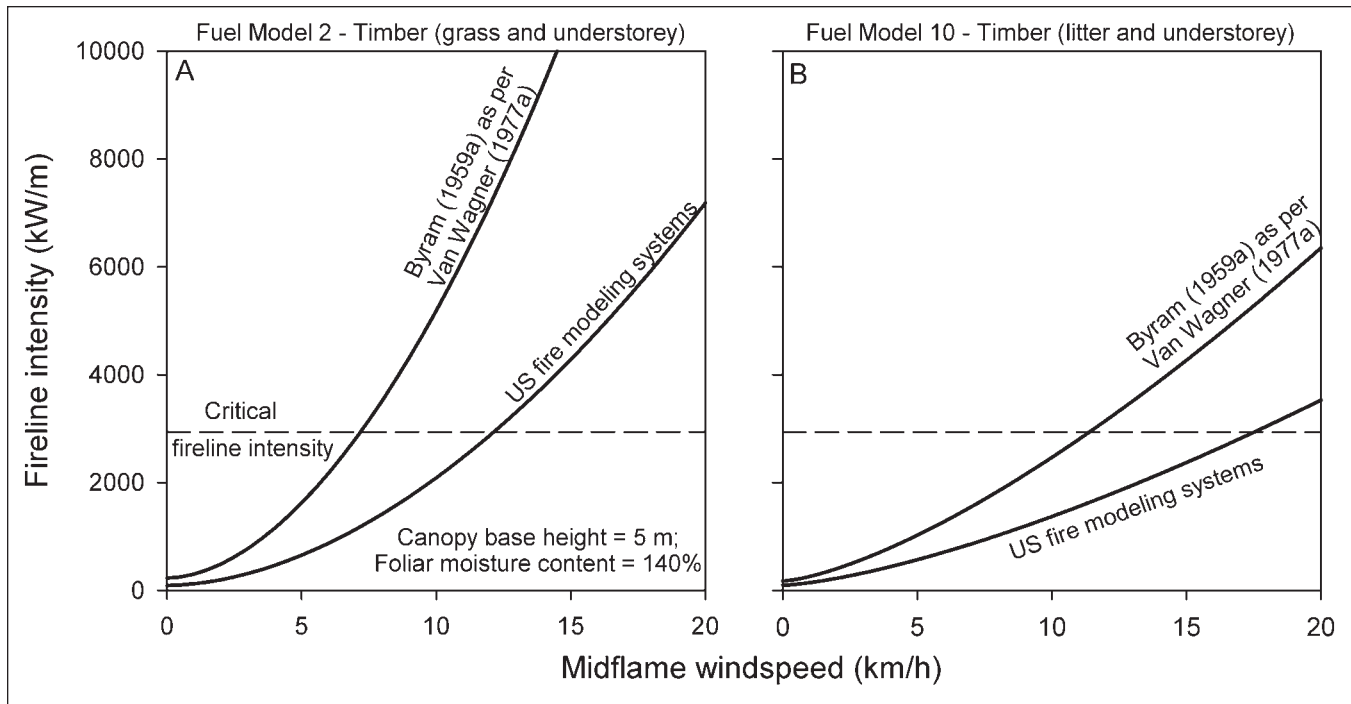

Figure 9-29—An example of the differences in the critical midflame windspeeds required for the onset of crowning resulting from the implementation of Van Wagner’s (1977a) crown fire initiation model in various U.S. fire behavior modeling systems for Fire Behavior Fuel Models 2–Timber (grass and understory) and 10–Timber (litter and understory) as described by Anderson (1982) (adapted from Cruz and Alexander 2010a). The following environmental conditions were held constant: slope steepness, 0 percent; fine dead fuel moisture, 4 percent; 10-h and 100-h time lag dead fuel moisture contents, 5 and 6 percent, respectively; live woody fuel moisture content, 75 percent; and live herbaceous fuel moisture content, 75 percent. The associated 6.1-m open winds would be a function of forest structure and can be approximated by multiplying the midflame windspeed by a factor ranging between 2.5 (open stand) and 6.0 (dense stand with high crown ratio) (Albini and Baughman 1979).

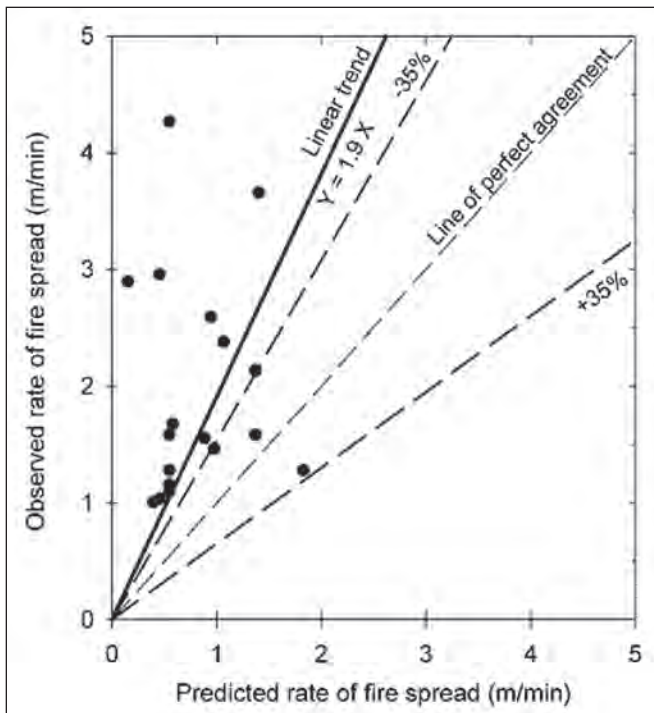

Figure 9-30—Observed head fire rates of spread >1.0 m/min associated with prescribed burning experiments in ponderosa pine forests of Yosemite National Park, California, versus predictions based on the Rothermel (1972) surface fire rate of spread model for fuel model 9—hardwood litter as described by Anderson (1982) (adapted from van Wagtenonk and Botti 1984). The dashed lines around the line of perfect agreement indicate the ±35 percent error interval. Similar underprediction trends were observed in mixed conifer–pine, mixed conifer–fir, and true fir forest fuel types.

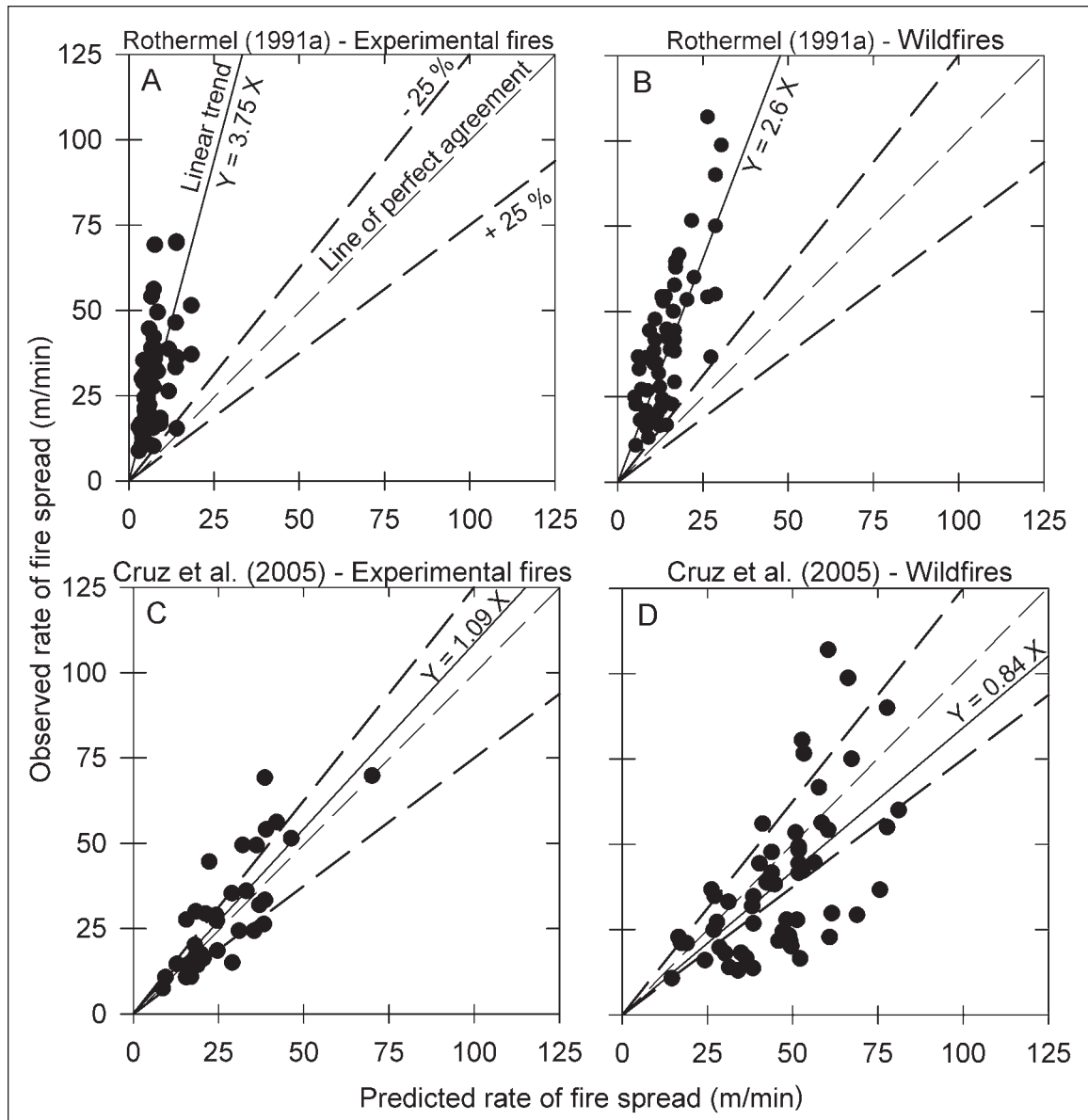

Figure 9-31—Observed rates of spread of experimental active crown fires and wildfires that exhibited extensive active crowning versus predictions based on (A and B) Rothermel’s (1991a) and (C and D) Cruz et al. (2005) crown fire rate of spread models (adapted from Cruz and Alexander 2010a). The dashed lines around the line of perfect agreement indicate the ± 35 percent error interval.

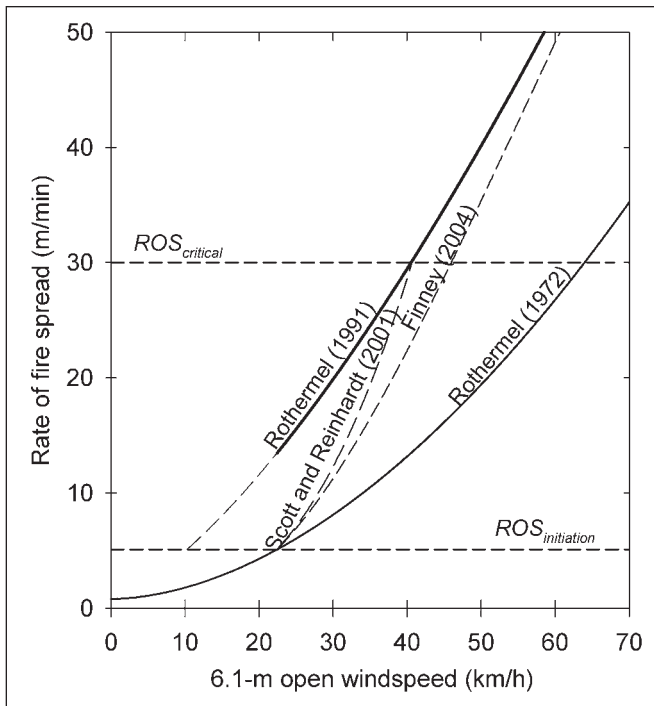

Figure 9-32—Comparison of the effect of crown fraction burned (CFB) functions on rate of fire spread developed by Scott and Reinhardt (2001) and Finney (2004) as used in various U.S. fire behavior modeling systems (e.g., NEXUS, FFE-FVS, FARSITE, FlamMap) in relation to the Rothermel (1972, 1991a) surface and crown fire rate of spread models and Van Wagner’s (1977a) criteria for the critical minimum spread rates for crown fire initiation ($ROS_{initiation}$) and active crowning ($ROS_{critical}$) for the Anderson (1982) Fire Behavior Fuel Model 2–Timber (grass and understory) with a wind-reduction factor of 0.2 (Albini and Baughman 1979), a canopy bulk density of 0.1 kg/m^3 , canopy base height of 1.5 m (adapted from Cruz and Alexander 2010a). A crown fraction burned function is not employed in BehavePlus. The following environmental conditions were held constant: slope steepness, 0 percent; fine dead fuel moisture, 6 percent; 10-h and 100-h time lag dead fuel moisture contents, 7 and 8 percent, respectively; live woody fuel moisture content, 75 percent; live herbaceous fuel moisture content, 75 percent; and foliar moisture content, 140 percent. The dashed portion of the Rothermel (1991a) curve represents output below the original dataset bounds for rate of spread. The Beaufort scale for estimating 6.1-m open windspeeds is presented in table 9-3. A guide to estimating probable maximum 1-min and momentary gust speeds is given in table 9-4.

New Zealand (Alexander 2008, Pearce and Alexander 1994).

The FBP System provides estimates of head fire spread rate, fuel consumption, fireline intensity, type of fire description (table 9-8). With the aid of an elliptical fire growth model, it gives estimates of fire area, perimeter, and perimeter growth rate as well as flank and backfire behavior characteristics for 16 major fuel types (De Groot 1993), 11 of which are subject to crowning (i.e., seven coniferous and four mixed-wood types). The type of fire classification in the FBP System is based on the CFB:

Type of fire	CFB
Surface fire	<0.1
Intermittent crown fire	0.1 to 0.89
Continuous crown fire	>0.9

The continuous crown fire classification is analogous to Van Wagner’s (1977a) active crown fire type, but the intermittent crown fire type, representing a very broad range in the degree of vertical fire development and behavior, can only be considered loosely applicable to his passive crown fire criteria.

The FBP System includes functions for the acceleration in rate of fire spread for a point source ignition to a quasi-steady-state equilibrium (McAlpine and Wakimoto 1991), including a prediction of the elapsed time to crown fire initiation. Emphasis is placed on the influences of fire weather (i.e., fuel moisture and wind) on potential fire behavior for a given fuel type (fig. 9-33) and the mechanical effects of slope steepness (fig. 9-17). The effects of fuel characteristics can be seen in the differences in environmental conditions across fuel types required to yield the same level of fire behavior (table 9-8).

The FBP System forms the basis for a major component of PROMETHEUS—the Canadian wildland fire growth simulation model (Tymstra et al. 2010), which is similar to FARSITE. Comparisons between hindsight reconstructed FBP System predictions and observed fire behavior derived from U.S. wildfire case studies have shown remarkably good agreement (e.g., Alexander 1991, 1992a, 2000b).

The FBP System is similar in many respects to predictive systems currently used in the United States. The

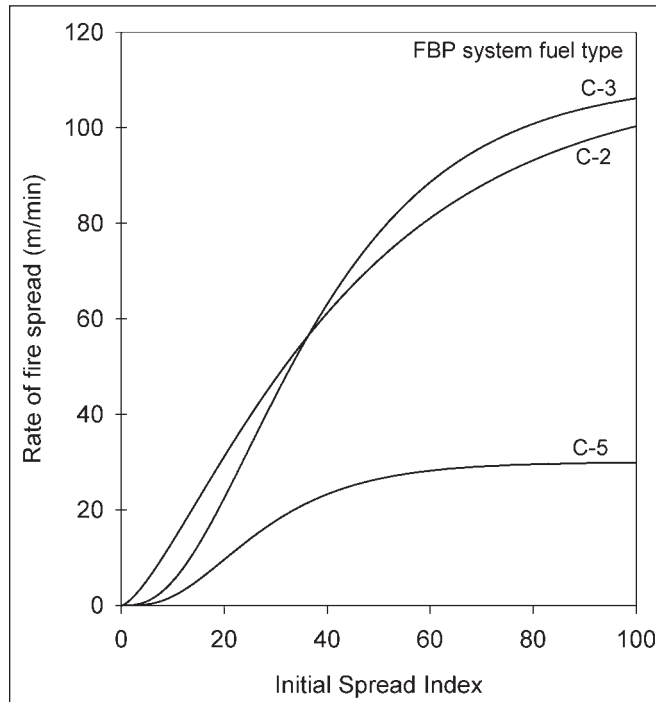

Figure 9-33—Rate of fire spread on level terrain to gently undulating terrain as a function of the Initial Spread Index component of the Canadian Forest Fire Weather Index System for three Canadian Forest Fire Behavior Prediction (FBP) System fuel types: boreal spruce (C-2); mature jack or lodgepole pine (C-3); and red and white pine (C-5). Typically, the lower section of the S-shaped curve represents surface fires, the upper flattening section represents continuous, active crowning, and the relatively steep intermediate section, a transition zone characterized by very high-intensity surface fires with significant torching and passive crown fire activity. Van Wagner’s (1977a) criiwb fire initiation model is incorporated into the BBP System by assigning nominal values for canopy base height to the coniferous and mixed-wood fuel types. Foliar moisture content can be estimated on a daily basis from calendar date, elevation, and geographical location (latitude/longitude) (Alexander 2010a, Forestry Canada Fire Danger Group 1992).

Table 9-8—Type of fire as a function of the Initial Spread Index (ISI)^a component of the Canadian Forest Fire Weather Index (FWI) System for the coniferous (C) and mixedwood (M) forest fuel types found in the Canadian Forest Fire Behavior Prediction (FBP) System

Fuel type identifier	Descriptive name	Surface fire	Intermittent crown fire	Continuous crown fire
		ISI	ISI	ISI
C-1	Spruce-lichen woodland	3 to 8	9 to 15	≥16
C-2	Boreal spruce	≤1	2 to 7	≥8
C-3	Mature jack or lodgepole pine	2 to 9	10 to 15	≥16
C-4	Immature jack or lodgepole pine	≤2	3 to 8	≥9
C-5	Red and white pine	3 to 25	26 to 40	≥41
C-6	Conifer plantation (7 m CBH)	≤8	9 to 17	≥18
C-7	Ponderosa pine/Douglas-fir	≤15	16 to 30	≥31
M-1	Boreal mixedwood—leafless 75C:25H	≤3	4 to 10	≥11
M-2	Boreal mixedwood—green 75C:25H	≤3	4 to 10	≥11
M-3	Dead balsam fir mixedwood—leafless	≤1	2 to 3	≥4
M-4	Dead balsam fir mixedwood—green	≤3	3 to 6	≥7

^a The ISI is a relative numerical rating that combines the effects of fine fuel moisture (based on past and current weather conditions) and wind speed on the expected rate of fire spread (Van Wagner 1987). In the above tabulation, level terrain, a foliar moisture content of 97 percent, and a Buildup Index (BUI) of 81 to 120 are assumed. The BUI component of the FWI System is a relative numerical rating of the fuel available for combustion based on fuel dryness as determined by past and current weather conditions (Van Wagner 1987). In addition, a canopy base height (CBH) of 7.0 m has been assigned to fuel type C-6, the M-1 and M-2 fuel types are assumed to comprise 75 percent conifer (C) and 25 percent hardwood (H), and the M-3 and M-4 fuel types are assumed to contain 100 percent dead fir.

Source: Adapted from Taylor et al. 1997.

principal difference is in the technical basis (Stocks et al. 2004a), reflecting on what Van Wagner (1971) called the “two solitudes” in wildland fire behavior research (box 8). The Rothermel (1972) surface fire model is based largely on laboratory fires and physical theory. The FBP System, on the other hand, is largely empirically based, representing the culmination of nearly 30 years of outdoor experimental burning (Alexander and Quintilio 1990) work in major Canadian fuel types (e.g., Alexander et al. 1991; Lawson 1973; Quintilio et al. 1977; Stocks 1987a, 1987b, 1989; Van Wagner 1964, 1968, 1986; Weber et al. 1987) coupled with monitoring and documentation of numerous high-intensity wildfires (e.g., Alexander and Lanoville 1987, Kiil and Grigel 1969, Stocks and Flannigan 1987, Van Wagner 1965). A training manual on the FBP System has been prepared by Hirsch (1996) based on Forestry Canada Fire Danger Group (1992), and a variety of interpretive aids exist (e.g., Alexander and Cole 1995, Alexander and DeGroot 1988, Alexander and Lanoville 1989, Cole and Alexander 1995).

Crown Fire Initiation and Spread (CFIS) System

The Crown Fire Initiation and Spread (CFIS) software system (Alexander et al. 2006) is a suite of empirically based models for predicting fire behavior (Alexander and Cruz 2009). These models are based largely on a reanalysis of the experimental fires carried out as part of developing the Canadian FBP System (Cruz 1999, Cruz et al. 2002). In this regard, the intention is to use the Cruz et al. (2005) active crown fire rate of spread model in the next generation of the CFFDRS (Wotton 2010).

The main outputs of CFIS are as follows (Alexander et al. 2006):

- Likelihood of crown fire initiation or occurrence based on two distinct approaches, one of which relies on the CBH or certain components of the Canadian FWI System (Cruz et al. 2003b), whereas the other is determined by the fine dead fuel moisture (table 9-4),

Box 8:

The Two Solitudes in Wildland Fire Research (from Van Wagner 1979b)

“... the researcher studying fire behaviour is continually faced with the choice between the theoretical and empirical approaches. He cannot solve his problem by pure physics. ... if he tries miniaturized laboratory modeling, he is up against awesome difficulties in scaling all the dimensions and energy transfer processes of a phenomenon that may be so much greater in size and intensity than anything he can amount in the laboratory. ... taking a more empirical approach, he may seek to light experimental fires in the real forest. He must sacrifice some control over burning conditions, but his main problem is to sample the whole range of intensity. It is easy enough to accumulate plenty of data in the low intensity range, but the main interest is in what happens when the fire weather is at its most severe; these moments come rather seldom and the practical difficulties of controlling the experiments are obvious. However, much good information about fire behaviour in a particular fuel can be gained from a very few successful experimental fires of say ½ to 5 ha in extent. ... [the] final recourse is to chase and observe accidental forest fires, a most frustrating business as anyone who has tried it will tell you. Nevertheless, by being in the right place and the right time in a very few choice occasions, some valuable information obtainable in no other way can be gathered, including various bits of detective work that can be done after the fire has cooled down.”

CBH, windspeed, and an estimate of surface fuel consumption (Cruz et al. 2004) (fig. 9-34).¹¹

- Type of crown fire (passive crown fire or active crown fire) and its associated rate of spread based on fine dead fuel moisture, CBD, and windspeed (Cruz et al. 2005) (figs. 9-35 and 9-36).
- Minimum spotting distance required to increase a crown fire’s overall forward rate of spread assuming a point ignition and subsequent fire acceleration to an equilibrium rate of spread based on the presumed crown fire rate of spread and ignition delay (Alexander and Cruz 2006) (fig. 9-25).

The primary models incorporated into CFIS have been evaluated against both outdoor experimental fires and wildfire observations as shown in figures 9-31C and 9-31D to be reasonably reliable (e.g., Alexander and Cruz 2006, Cronan and Jandt 2008, Stocks et al. 2004b). Output from CFIS is now being used as a proxy for reality by some users (e.g., Schreuder et al. 2010).

Scott (2006) claimed that the small size of the experimental fires used in the development of CFIS “may preclude direct application to real crown fires.” However, Alexander et al. (1991) had demonstrated earlier on that spread rate data collected from outdoor experimental fires does in fact mimic real-world situations.

The CFIS does allow one to evaluate the impacts of proposed fuel treatments on potential crown fire behavior based on the ability to manipulate three characteristics of a forest fuel complex (i.e., available surface fuel load, CBH and CBD) using silvicultural techniques (e.g., Agee and Skinner 2005; Graham et al. 1999, 2004; Johnson and Peterson 2005; Keyes and O’Hara 2002; Keyes and Varner 2006; Scott 1998b, 1998c, 1998e). Whitehead et al. (2007),

¹¹ Model output is expressed as the probability (table 9-9) of initiating a crown fire between 0 and 100 percent for the stated environmental conditions as defined by the inputs. The probabilities are estimates of the likelihood that allow uncertainty to be quantified. A threshold probability of 50 percent is presently assumed to separate a surface fire (<50 percent) from a crown fire (>50 percent). The horizontal dashed line in each graph in figure 9-34 represents this threshold value for the onset of crowning. Further experience with the CFIS may eventually suggest otherwise.

Table 9-9—Interpreting probabilities

Probability	Interpretation
<0.01	Extremely unlikely
0.01 to 0.10	Very unlikely or very improbable
0.10 to 0.33	Unlikely or improbable
0.33 to 0.66	Medium probability
0.66 to 0.90	Likely or probable
0.90 to 0.99	Very likely or very probable
>0.99	Virtual certainty

Source: Pollack 2003.

for example, examined the effect of reducing CBD by partial cutting on the threshold between passive and active crowning using CFIS.

The CFIS is considered most applicable to free-burning fires that have reached a pseudo–steady state, burning in live, boreal, or boreal-like conifer forests found in western and northern North America (i.e., it is not directly applicable to insect-killed or otherwise “dead” stands). The models that comprise CFIS are not applicable to prescribed fire or wildfire situations that involve strong convection activity as a result of the ignition pattern. Level terrain is assumed, as the CFIS does not presently consider the mechanical effects of slope steepness (Van Wagner 1977b) on crown fire behavior, although this is being planned for in a future version of the system. Furthermore, it is assumed that the heavy fuel moisture threshold (Lawson et al. 1994, Lawson and Dalrymple 1996) found in mature, high-elevation spruce-fir stands (Williams and Rothermel 1992) has been reached.

Some Other Empirically Based Approaches

Some Australian eucalypt stand types are prone to crowning (e.g., McCaw et al. 1988). The basic index of the Australian Forest Fire Danger Meter (McArthur 1967) provides for the prediction of wildfire behavior characteristics in terms of forward rate of fire spread, flame height, and spotting distance on level to gently undulating terrain in a dry eucalypt forest with fine fuel quantities of 1.25 kg/m² (Luke and McArthur 1978). The meter also identifies the general conditions required for crown fire development in this fuel type (fig. 9-37). Prediction can be adjusted for the mechanical effects of slope steepness and varying quantities

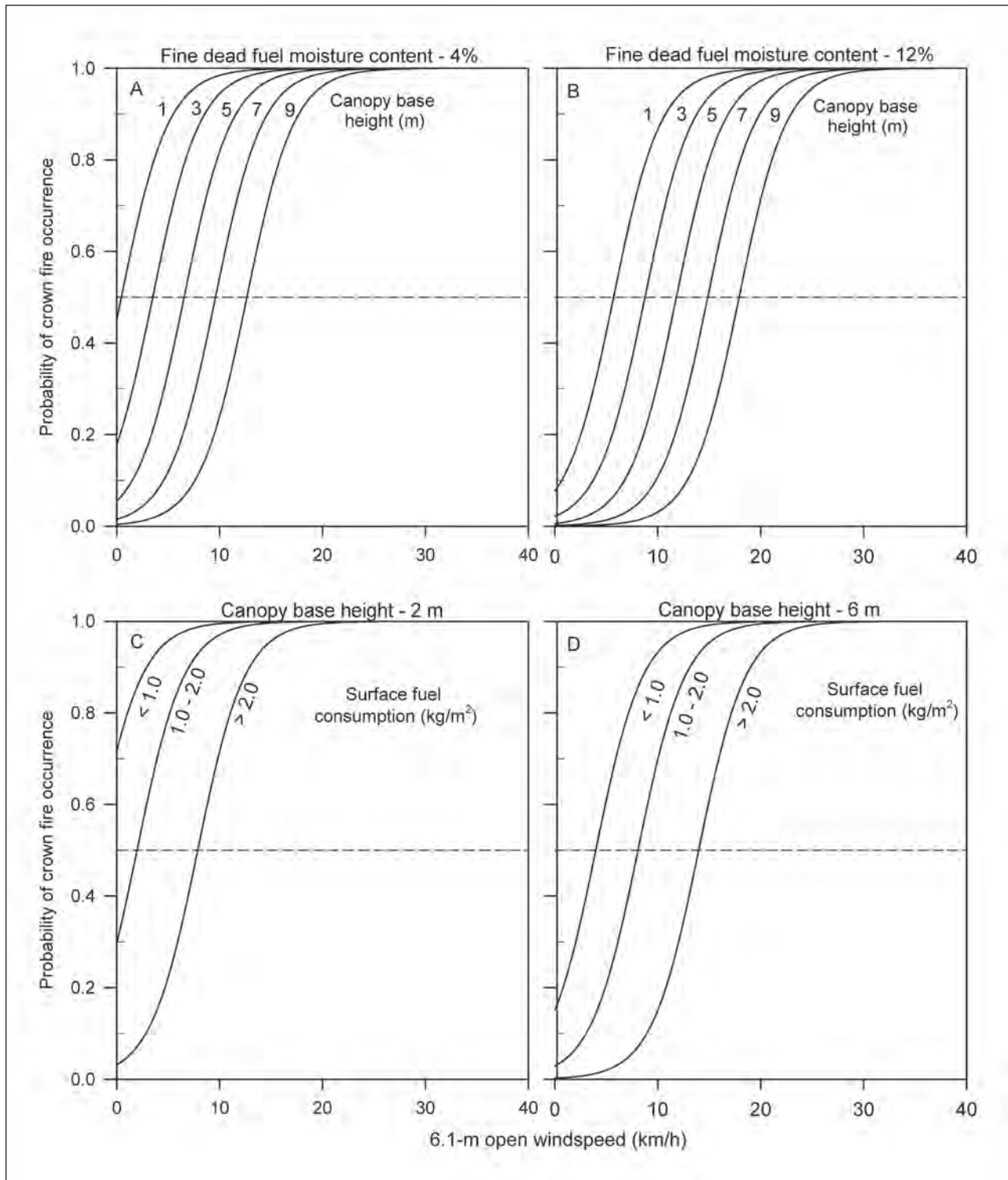

Figure 9-34—The likelihood of crown fire occurrence as (A-B) a function of canopy base height and windspeed for two fine dead fuel moisture levels, assuming a surface fuel consumption of 1.0 to 2.0 kg/m² and (C-D) as a function of surface fuel consumption and windspeed, assuming a fine dead fuel moisture of 4 percent, based on the Cruz et al. (2004) probability model. The horizontal dashed line in each graph represents the approximate threshold value for the onset of crowning (i.e., 0.5 probability of crown fire occurrence). The Beaufort scale for estimating 6.1-m open windspeeds is presented in table 9-3. A guide to estimating probable maximum 1-min and momentary gust speeds is given in table 9-4.

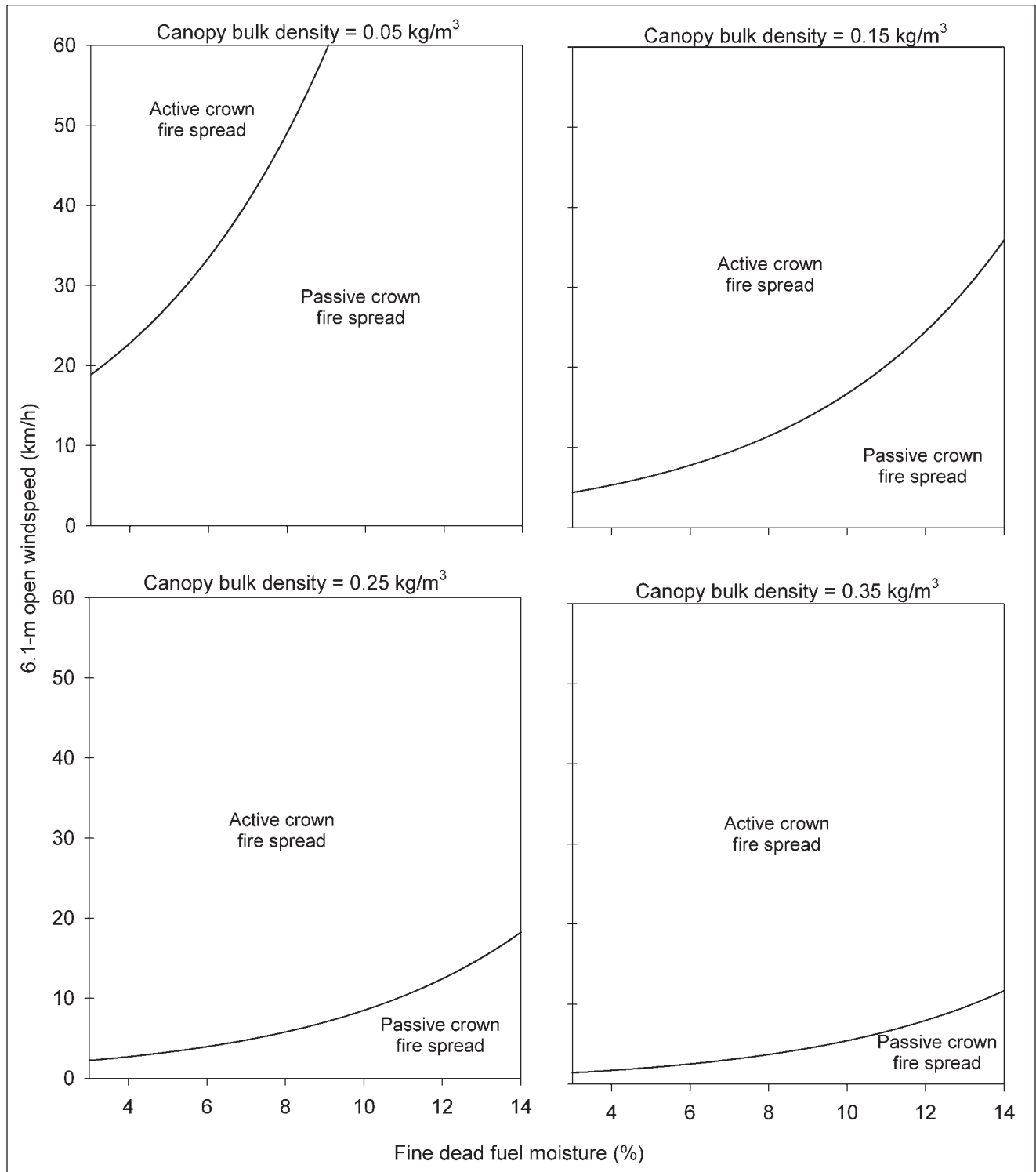

Figure 9-35—Threshold conditions for passive versus active crown fire spread in terms of windspeed and fine dead fuel moisture for four canopy bulk density levels based on the Cruz et al. (2005) crown fire rate of spread models and Van Wagner’s (1977a) criteria for active crowning. The Beaufort scale for estimating 6.1-m open windspeeds is presented in table 9-3. A guide to estimating probable maximum 1-min and momentary gust speeds is given in table 9-4.

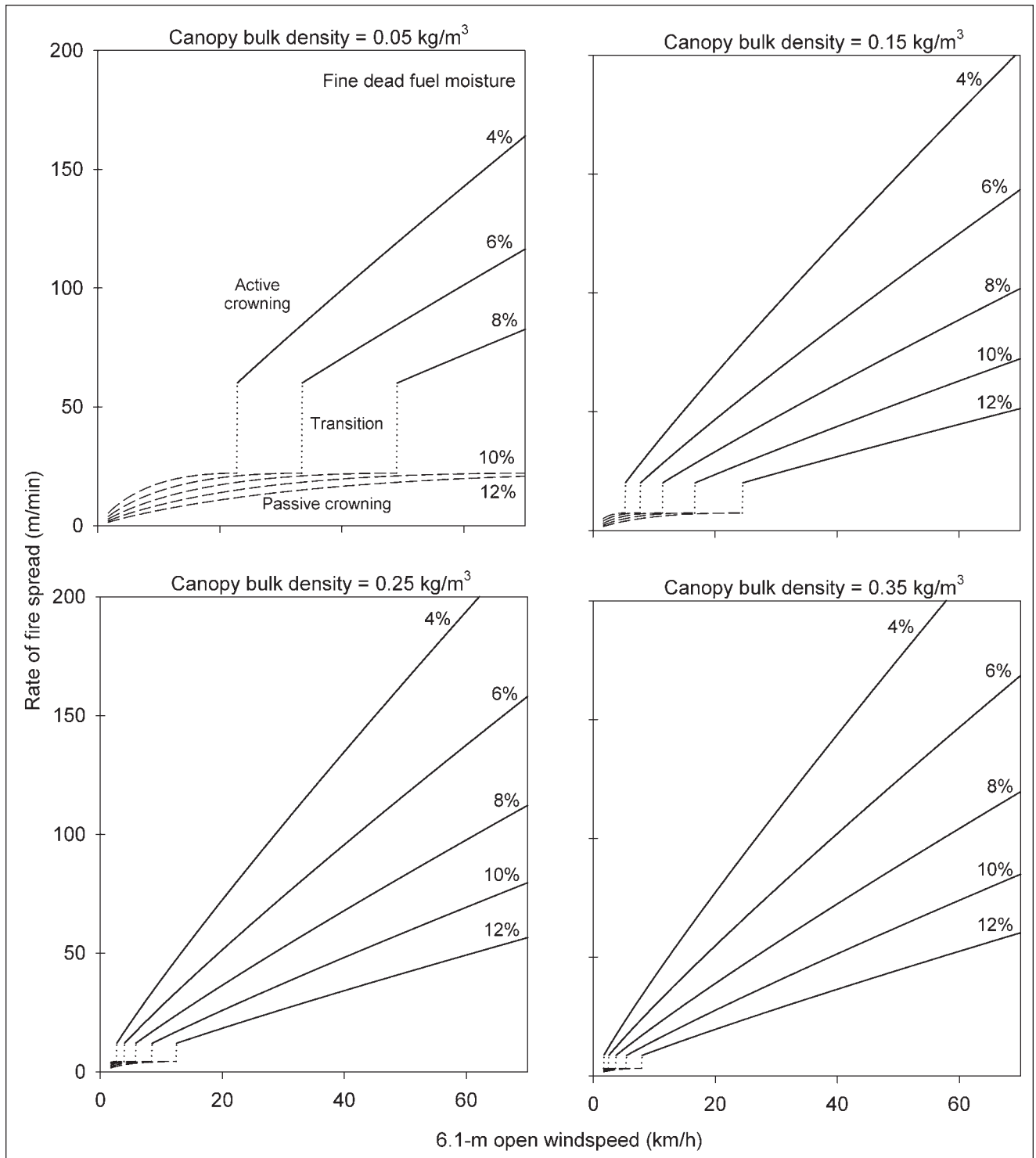

Figure 9-36—Passive and active crown fire spread rates as a function of windspeed and fine dead fuel moisture for four canopy bulk density levels based on the Cruz et al. (2005) crown fire rate of spread models. The vertical “kinks” in the fine dead fuel moisture curves are considered to represent the windspeed thresholds between passive and active crowning. The Beaufort scale for estimating 6.1-m open windspeeds is presented in table 9-3. A guide to estimating probable maximum 1-min and momentary gust speeds is given in table 9-4.

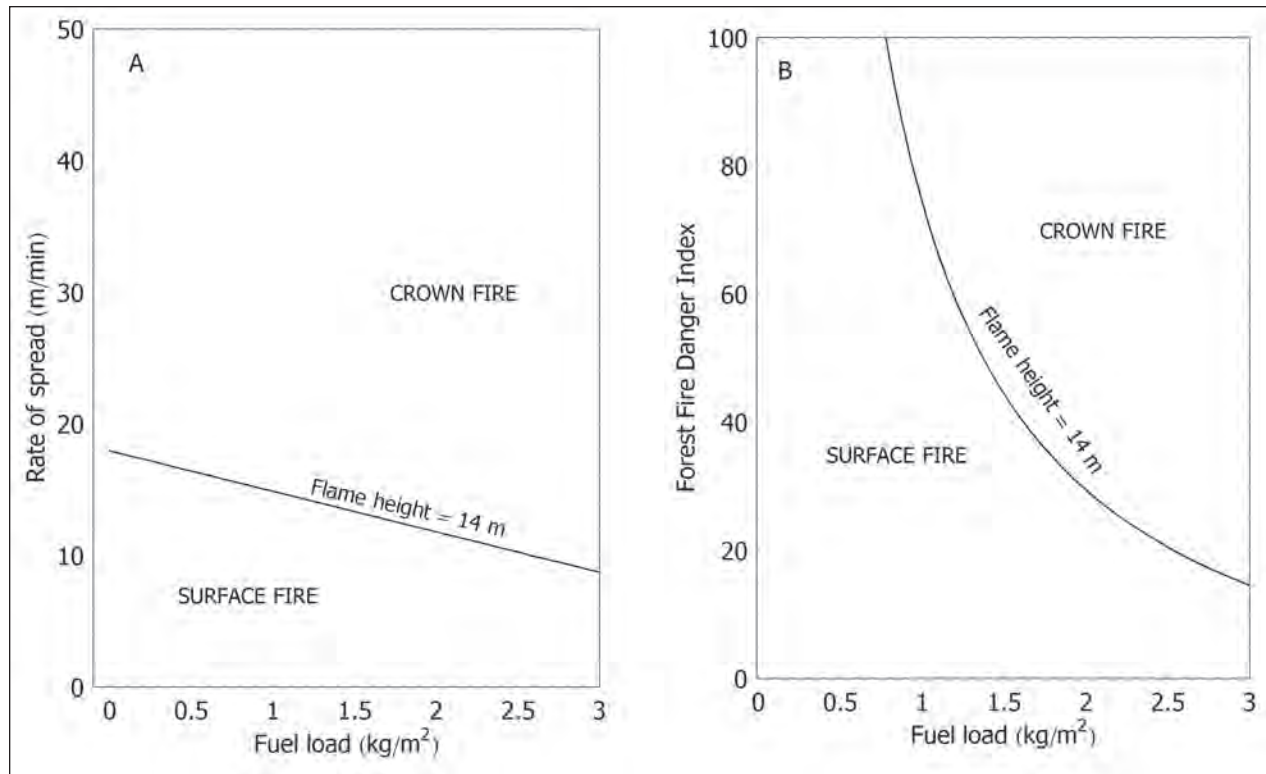

Figure 9-37—Graphical representation of McArthur's (1967, 1973) guide to sustained crown fire propagation in Australian eucalypt forests based on (A) rate of spread and fuel load and (B) Forest Fire Danger Index and fuel load assuming that crowning occurs once flame heights exceed 14 m.

of fuel (Cheney 1968). Fire behavior characteristics in pine plantations, including those associated with crowning, have been related to index values (Douglas 1964, Luke 1962, McArthur 1965).

Roussopoulos (1978a, 1978b) used Rothermel's (1972) surface fire and Van Wagner's (1977a) crown fire models to determine crowning thresholds for broad fuel types found in northeastern Minnesota where an extensive forest-fire fuel inventory had been carried out in the Boundary Waters Canoe Area of the Superior National Forest. He chose to present the results in the form of graphical aids or "nomographs" similar to those constructed by Albin (1976b) for the Anderson (1982) fuel models.

Bruner and Klebenow (1979) developed the following simple formula for predicting whether a successful prescribed burn (i.e., what effectively amounts to a "controllable" crown fire) was possible in pinyon-juniper woodlands on the basis of 30 prescribed fires carried in Nevada on

level terrain: score = maximum windspeed (mi/h) + air temperature (°F) + vegetative cover (percentage). Resultant scores are interpreted as follows:

- Score <100: burning conditions are such that fires will not carry.
- Score of 110 to 125: fires will carry, but continual retorching will be necessary.
- Score of 125 to 130: burning conditions are optimal for a self-sustaining fire following ignition.
- Score >130: burning conditions are too hazardous for prescribed burning.

The authors acknowledged that there appeared to be a very narrow separation between conditions for successful prescribed burning and those that would result in an uncontrollable high-intensity wildfire that would escape the confines of the prescribed burn unit, a fact that is substantiated by general field observations (e.g., Hester 1952).

Physics-Based Models

Physics-based models are formulated on the basis of the chemistry and physics of combustion and heat-transfer processes involved in a wildland fire (Grishin 1997, Morvan 2011, Sullivan 2009b). They range in complexity from models for calculating rate of fire spread based solely on the radiation from the flaming front (e.g., Albin 1996) to three-dimensional models coupling fire and atmospheric processes. Examples of the latter include FIRETEC (Linn et al. 2002), FIRESTAR (Dupuy and Morvan 2005), and the Wildland-Urban Interface Fire Dynamics Simulator (WFDS) (Mell et al. 2007).

Physically based models hold great promise in being able to advance our theoretical understanding of wildland fire dynamics and could possibly be used for operational prediction of wildland fire behavior in the future or at least lead to the improvement of existing operational models (Sullivan 2009b). Van Wagner (1985) emphatically noted that:

The fire world would beat a path to the door of the modeller who could account for vertical gradients and interruptions in moisture content and fuel density as well. Crowning fire is the most obvious application for such a comprehensive model.

By their completeness, these models should be able to predict not only the development (Porterie et al. 2003) but the demise or cessation, spread rate, fuel consumption, intensity, and flame dimensions of crown fires in relation to any combination of fuel, weather, and topographic variables. In recent years, these models have been extensively used as research tools to evaluate the effects of fuel treatments (Contreras et al. 2012), canopy fuel structure (Linn et al. 2005; Parsons et al. 2010, 2011), and mountain pine beetle attack on crown fire dynamics (Hoffman et al. 2012, 2013, Linn et al. 2013). Nonetheless, the capacity of these models to describe crown fire behavior for such applications is still open to question (Alexander and Cruz 2013a) given that the evaluation against any empirical crown fire data undertaken to date is limited to two fires (Linn et al. 2012).

Forty-two years ago, Lindenmuth and Davis (1973) suggested that “Quite likely the data from empirical study will be useful in making the inputs for theoretical models more accurate.” What appears to be happening is the continuing emergence of empirical and physically based approaches (Cruz and Gould 2009, Sullivan 2009b, Van Wagner 1985). An example of such an approach is the semi-physically based crown fuel ignition model (CFIM) developed by Cruz (2004) to predict the onset of crowning based on fundamental heat transfer principles (Cruz et al. 2006b, 2006c). A series of submodels that take into account surface fire characteristics along with canopy fuel properties is used to predict the ignition temperature of canopy fuels above a spreading surface fire (fig. 9-38). An evaluation of CFIM has been undertaken involving a sensitivity analysis of input

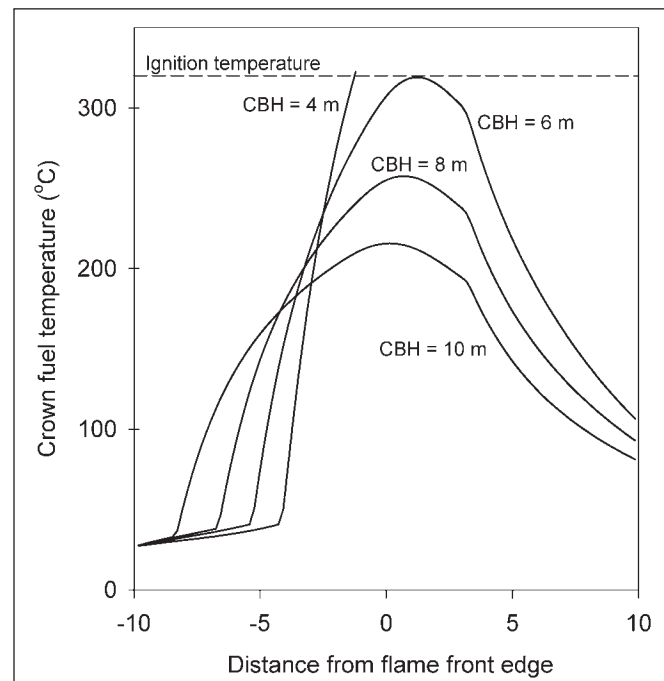

Figure 9-38—Estimated crown fuel temperature for four canopy base heights above a surface fire based on the Canopy Fuel Ignition Model (CFIM) of Cruz et al. (2006b). The fuel particle for which the heat transfer calculation was done is located directly at the flame front edge (i.e., $x = 0$). The maritime pine stand with shrubby understory fuel model of Cruz and Fernandes (2008) was used. A stand height of 12 m and an available surface fuel load of 0.7 kg/m^2 were assumed. The following environmental conditions were held constant: slope steepness, 0 percent; fine dead fuel moisture, 9 percent; and foliar moisture content, 160 percent.

parameters, comparison against other similar models under different burning conditions, and testing against outdoor experimental fires (Cruz et al. 2006a). Results have been favorable and provided new insights into the factors controlling the initiation of crown fires.

Another example of the merging of empirical and physical modeling approaches was the International Crown Fire Modeling Experiment (ICFME) (Stocks et al. 2004a). One of the objectives of this experimental burning program carried out in the Northwest Territories of Canada from 1995 to 2001 (Alexander 2005, Alexander et al. 2001) was to test a newly developed, deterministic physical model for predicting crown fire rate of spread (Albini 1996, Butler et al. 2004b, Call 1997), which included an empirically based model for predicting fuel consumption based on fuel particle diameter and moisture content (Call and Albini 1997). Measurements of flames' radiometric properties and temperatures (Butler et al. 2004a) allowed for the parameterizing of the heat-transfer components in Albini's (1996) crown fire rate of spread model. Model evaluation indicated that the model predicted the relative response of fire spread rate to fuel and environmental variables, but it consistently overpredicted the magnitude of the spread rates observed on the ICFME crown fires.

Not all physically based models for predicting wildland fire spread specifically take into account the effects of spotting in increasing a fire's rate of spread. The effects of spotting on a fire's overall rate of advance are implicitly accounted for in both the FBP System and the Rothermel (1991a) crown fire rate of spread model as a result of the empirical nature of their development (i.e., the use of wildfire observations as a data source). This assumes, however, that the fuels are continuous. Neither approach indicates how barriers to fire spread are to be handled. Short-range spotting from a crown fire is presumably able to easily breach fuel discontinuities of up to 100 m in width (Stocks et al. 2004b, Taylor et al. 2004). Nominal spotting from crown fires is undoubtedly capable of breaching even much wider barriers, perhaps up to 1000 m (Alexander et al. 2004). What is unknown, however, is how much of a reduction

there will be in the head fire rate of spread as a result of the time delay involved (which might possibly be 30 to 60 min or longer) for the fire to resume its forward, equilibrium rate of advance.

Albini (1979) developed a physically based model for predicting the maximum spotting distance from single or group tree torching that covers the case of intermediate-range spotting of up to perhaps 1.5 to 3.0 km; he also developed similar models for burning piles of slash or "jackpots" of heavy fuels¹² (Albini 1981a) and wind-aided surface fires in non-tree canopied fuel complexes such as grass, shrubs, and logging slash (Albini 1983a, 1983b). This model is included within the BehavePlus modeling system, and a manual procedure is given in Rothermel (1983). Rothermel (1991a) pointed out at the time he prepared his guide that no model existed for predicting the spotting distances for running or active crown fires. Venkatesh et al. (2000) subsequently extended Albini's (1979) model to the case of wind-driven crown fires. The result was a 20- to 25-percent increase in spotting distance. However, no testing of this model has been undertaken to date to our knowledge. The Venkatesh et al. (2000) model, like the one developed by Albini (1979), provides a prediction of the maximum firebrand transport distance. Determining whether a given ember or firebrand will actually cause a spot fire must still be assessed based on its ignition probability (e.g., Beverly and Wotton 2007, Lawson 1973, Rothermel 1983).

More recently, an alternative predictive system has been put forth for estimating the maximum spotting distance from active crown fires as a function of the firebrand particle diameter at alighting based on three inputs, namely, canopy top height, free flame height (i.e., flame distance above the canopy top height), and the windspeed at the height of the canopy (Albini et al. 2012). Although the system has not been specifically validated, the estimates produced by the system (fig. 9-39) appear realistic in light of existing documented observations.

¹² Beginning in the late 1980s, some wildland fire behaviour analysts or specialists began applying the Albini (1981a) maximum spot fire distance model for burning piles to burning structures in the wildland-urban interface (Steele, J.K. 2011. Personal communication. Confederated Salish and Kootenai Tribes Division of Fire, PO Box 278, Pablo, MT 59855).

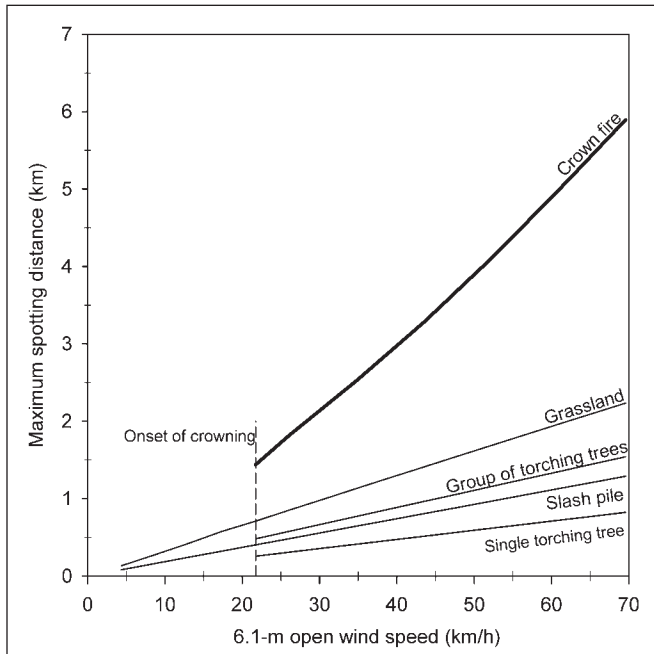

Figure 9-39—Comparison of predictions for maximum potential spotting distance over level terrain as a function of windspeed for a specified set of burning conditions based on models developed by Frank A. Albini (adapted from Albini et al. 2012). A 6.1-m open windspeed of around 5 km/h is considered required for a consistently heading fire (Cheney et al. 1998). The Beaufort scale for estimating 6.1-m open windspeeds is presented in table 9-3. A guide to estimating probable maximum 1-min and momentary gust speeds is given in table 9-4.

Example of a Practical Application of Linking Empirical and Physically Based Models

Pine Plantation Pyrometrics (PPPY) is a new modeling system developed to predict fire behavior in industrial pine plantations in Australia over the full range of burning conditions in relation to proposed changes in fuel complex structure from fuel treatments (Cruz et al. 2008). The system comprises a series of submodels, including CFIM and elements of CFIS, that describe surface fire characteristics and crown fire potential in relation to the surface and crown fuel structures, fuel moisture contents, and windspeed (fig. 9-40). A case study application of the PPPY modeling system has highlighted the complex interactions associated with fuel treatments such as pruning and thinning have on surface and crown fire behavior potential (fig. 9-41). It is

also noteworthy that no definite reduction or increase in rate of spread was identified. While a direct evaluation of the system's overall performance has yet to be undertaken, its main components have been evaluated against independent datasets with encouraging results (Cruz et al. 2015).

Implications for Fire and Fuel Management

In the broadest sense, the general conditions favorable for the development of crowning in conifer forests have been known for some time now (e.g., Beale and Dieterich 1963, Byram 1954, Gisborne 1948, Rothermel 1995) and also apply to nonforested fuel types as well that exhibit high rates of fire spread and fireline intensities or very long flame lengths (e.g., Butler and Reynolds 1997). These include:

- Continuous fine fuels in sufficient quantity and arrangement, both vertically and horizontally.
- A dry spell of sufficient length to reduce the moisture content of dead fuels to a uniformly low, critical level coupled with high ambient air temperatures and low relative humidities.
- Strong prevailing winds or steep slopes.

In the past 25 years or so, these conditions have, in turn, been crudely codified in various forms suitable for use by field personnel. Other aspects of the fire environment such as low foliar moisture content (Reifsnnyder 1961), high foliar heat content (Chrosciewicz 1986a), presence of flammable oils and resins in the needle foliage (Hough 1973, Philpot and Mutch 1971) or drought (Cohen 1989; Cohen et al. 1987, 1989, 1990) may lead to an increase in crown fire potential but by themselves have not been found as of yet to be a major predisposing factor.

Assuming a threshold level in dryness has been reached in the forest floor layer, the potential for crown fire development and spread would generally follow the daily diurnal cycle in fire weather conditions, typically peaking in late afternoon (Beck et al. 2002). However, crown fire activity can extend late into the day if fire weather conditions are favorable for maintaining the moisture content of fine, dead surface fuels at low levels (Hartford and Rothermel 1991).

Rothermel (1991a) quite rightly pointed out that “Fires are seldom uniform and well behaved.” Given the chaotic nature of most extreme fire phenomena, can we expect the

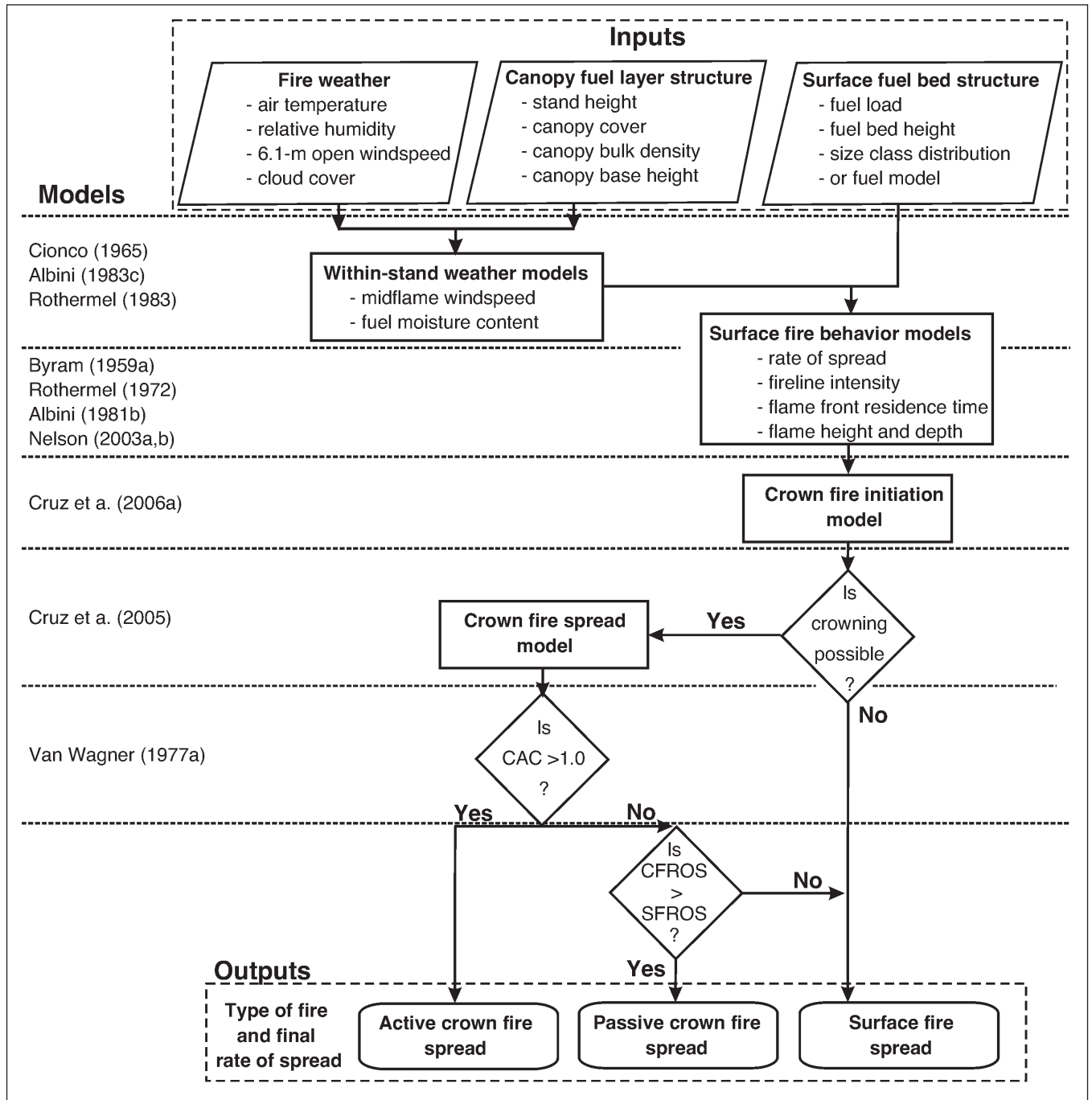

Figure 9-40—Flow diagram of the Pine Plantation Pyrometrics (PPPY) modeling system for predicting fire behavior in exotic pine plantations (adapted from Cruz et al. 2008). CAC is the criteria for active crowning (Van Wagner (1977a), CFROS is the crown fire rate of spread, and SFROS is the surface fire rate of spread.

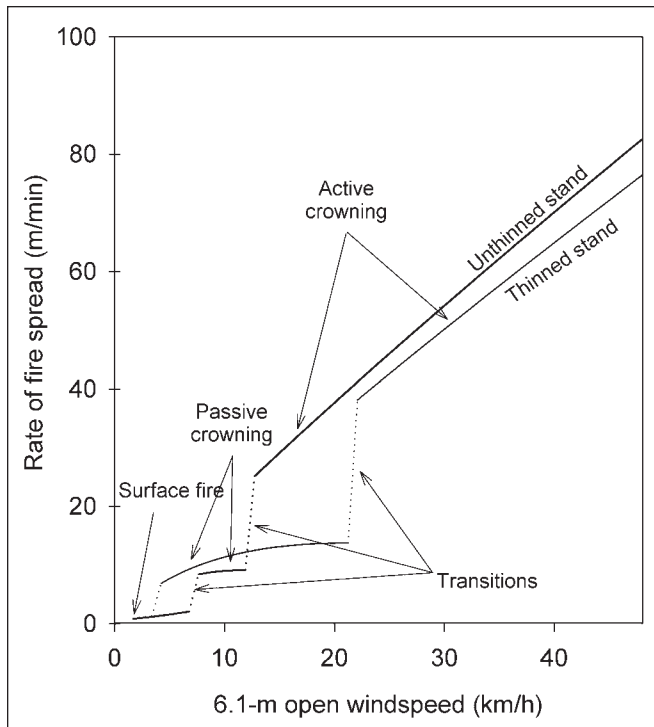

Figure 9-41—Head fire rate of spread as a function of windspeed for 12-year-old thinned (50 percent basal area reduction treatment) and unthinned pine plantation stands based on the Pine Plantation Pyrometrics (PPPY) modeling system (adapted from Cruz et al. 2008). The fuel complex characteristics for the thinned and unthinned stands were respectively: surface fuel available for combustion, 1.1 and 0.5 kg/m²; canopy base height, 1.7 and 0.9 m; and canopy bulk density, 0.05 and 0.1 kg/m³. Given an air temperature of 40 °C and a relative humidity of 20 percent, the fine dead fuel moistures for the surface litter were, in turn, judged to be 5 and 7 percent, respectively. Foliar moisture content was set at 100 percent in both cases and level to gently undulating terrain was assumed. The Beaufort scale for estimating 6.1-m open windspeeds is presented in table 9-3. A guide to estimating probable maximum 1-min and momentary gust speeds is given in table 9-4.

Box 9:

Underestimating Crown Fire Potential in Conifer Forests

By linking Rothermel's (1972, 1991a) models for predicting surface and crown fire rates of spread with Van Wagner's (1977a, 1993) crown fire transition and propagation models, Scott and Reinhardt (2001) developed two crown fire hazard indices—the Torching Index (TI) and the Crowning Index (CI). The TI and CI represent the threshold windspeeds required for the onset of crowning and active crown fire propagation in conifer forests, respectively. Each TI and CI value is tied to a unique set of surface fuelbed characteristics (expressed in terms of a stylized or custom fuel model), dead and live moisture contents of surface fuels, crown fuel properties (i.e., canopy base height and bulk density, foliar moisture content), and slope steepness. These two indexes have proven to be very popular amongst both researchers and fire managers alike.

Cruz and Alexander (2010a) found that many simulation studies that relied upon the TI and CI as a means of assessing crowning potential in relation to fuel treatment effectiveness, often produced unrealistic outcomes considering the associated environmental conditions and fuel characteristics. Quite often critically dry fuel moisture levels were specified (i.e., 1.5 to 3 percent) along with very low canopy base heights and relatively high canopy bulk densities and yet the simulations suggested that exceedingly strong winds were commonly required to initiate crowning and for fully developed or active crown fires to occur. In many cases, these simulation studies have reported TI and CI values for gale force wind conditions (i.e., sustained winds greater than about 100 km/h). Such winds seldom occur inland, but, when they do, they generally result in trees and whole forest stands being blown down over large areas (table 9-6). Scott (2006) suggested that these very high wind velocities simply indicated “a very low potential for initiating a crown fire” and that windspeeds at or in excess of 100 km/h “occur so rarely that crown fire can be considered nearly impossible to initiate,” thereby implying there is no need for any concern.

Box 9 (continued)

It could be argued that the outcomes of these simulation studies are realistic in that they simply reflect the fact that both strong winds and dry fuels are required to achieve any sort of torching or crowning activity. While this may be intuitively true for areas that have undergone some form of fuel treatment such as prescribed burning, for control or untreated areas the simulation results do not appear realistic based on general observation and experience. For example, Simard et al. (2011) indicated that TI levels above 700 km/h were necessary for passive crowning to occur in well-stocked, undisturbed lodgepole pine stands with an average CBH of 3.5 m.

Clearly, burning conditions specified in these simulation studies are not necessarily representative of those associated with large, high-intensity wildfires that exhibit extensive crowning. For example, the crown fire run in lodgepole pine forests on the 1988 North Fork Fire that threatened the Old Faithful Inn complex in Yellowstone National Park occurred at a fine dead fuel moisture content of 6 percent with windspeeds of around 25 km/h (Thomas 1991).

behavior of crown fires to ever really be truly predictable? That depends on how accurate you expect the prediction to be. Certainly the minute-by-minute movement of a crown fire will probably never be predictable.

We should also continue to expect “exceptions to the rule” (e.g., Alexander 2004). Byram (1954) summed up this sentiment very well:

As more case-history fires are studied, it is possible to assemble a collection of statements about these fires which could be called the facts of fire behavior, or perhaps better, the facts of extreme fire behavior. It seems permissible to call them facts, because more investigators would probably agree on their essential meaning even though different investigators might explain them differently. Possibly the simplest way to define and introduce the problem of extreme fire behavior is to list known conditions associated with blow-ups.

He went on to provide a list that “contains many seeming contradictions which any effective solution must resolve” (Byram 1954, pp. 3-4). That list is presented in chapter 1 of this volume.

Alexander and Cruz (2006) have shown that there is a certain degree of unexplained variation in crown fire rate of spread even in the most idealized field situations. Interestingly enough, the same applies to laboratory fires involving so called reproducible fuelbeds. However, in looking at crown fire propagation across longer timeframes (e.g., 30 min to several hours), the available data have shown that some models and modeling systems are very capable of predicting fire spread within a margin of error that is useful to fire managers. Nevertheless, given the coarseness and uncertainty associated with the inputs in the crown fire initiation and propagation models, managers should be wary of their use for near-real-time predictions of fire behavior. Underestimating the potential for the onset of crowning under conditions that would sustain active crown fire propagation can, in turn, lead to substantial underpredictions in crown fire rate of spread and fireline intensity. Recent state-of-the-knowledge reviews have shown that there are limits to what can be expected from rate of fire spread models but that there are ways to deal with the uncertainty in model predictions (Alexander and Cruz 2013b, Cruz and Alexander 2013).

The value of utilizing a Monte Carlo-based ensemble method to predicting wildland fire behavior has recently been demonstrated by Cruz (2010). This approach provides for error bounds to be established and a probabilistic output of the uncertainties associated with model predictions, and allows one to capture the variability in bi-modal fire propagation systems, such as encountered when a fire transitions back and forth between surface and ladder fuels or surface/understorey fuels and overstorey crown fuels, such as occurs in situations involving intermittent crowning (Cruz and Alexander 2009).

Models or guides that have a good fundamental framework and a solid empirical basis presumably predict fire behavior well when used for conditions that are within the database used in their development (Sullivan 2009a). Overestimates of fire behavior can easily be readjusted

without serious consequences. However, underestimates can be potentially disastrous (Cheney 1981). The underprediction trends in predictions of crown fire behavior (box 9) mentioned earlier on should be of concern (Alexander and Cruz 2013a). If a system predicts or simulates that a fire will behave as a moderate-intensity surface fire under extreme fire weather conditions, why would it be necessary to undertake any form of fuel treatment or even be concerned about the general flammability of an area? Model underestimates of crowning potential can lead people to put themselves in grave danger. Considering that fire behavior prediction systems are used in gauging the need and timing of community evacuations associated with wildland-urban interface fires, underpredicting a fire's forward rate of spread by a factor of three has some serious ramifications (Anguelova et al. 2010). Creditable estimates of crown fire potential are also required in prescribed burning (Bryant et al. 1983, Custer and Thorsen 1996, Racher 2003, Woodard et al. 1983, Woodard and Van Nest 1990, Zimmerman 1990), including escape potential (Archibald et al. 1994).

It has been suggested that most wildland fire operations personnel base their expectations of how a fire will behave largely on experience and, to a lesser extent, on guides to forecasting fire behavior (Burrows 1984). Experienced judgement is needed in any assessment of wildland fire potential, but it does have some limitations (Gisborne 1948). The same can be said for mathematical models and computerized decision support systems. Given the present realities, practical knowledge and sound professional judgment coupled with experience are still needed and perhaps should take on an even more prominent role when it comes to adjusting, interpreting, and applying surface and crown fire behavior predictions (Andrews 1980, Beighley and Bishop 1990, Rothermel 1991c). In this regard, the comments of Williams and Rothermel (1992) seem very apropos:

The best chance for success in fire behavior prediction requires a mix of fire experience with analytical modeling methods. But in situations where conditions are beyond the limits or outside the assumptions of the models, fire predictions must rely even more on intuitive judgements. Such judgements

could be more easily made if managers know general patterns of fire behavior through a full range of burning conditions.

Predicting wildland fire behavior is, after all, both an art and a science (Alexander 2009c, Alexander and Thomas 2004, Barrows 1951, Rothermel 1983, Scott et al. 2014).

Until recently, the “art” side of forecasting or predicting wildland fire behavior (e.g., Weick 2002) has been largely ignored as a field of endeavor in wildland fire research. In this respect, the “Learning From the Experts” videos created from the interviews associated with Fire Management Deep Smarts Project undertaken by former fire behavior analyst Dave Thomas with the support of the Wildland Fire Lessons Learned Center, the Aldo Leopold Wilderness Research Institute, and National Park Service–Aviation and Fire Management, (Thomas et al. 2012) should prove valuable (box 10). “Deep Smarts” represents experienced-based wisdom amongst individuals who by virtue of their intuition, judgment, and knowledge are considered experts in their field (Leonard and Swap 2005).

Wildland fire research has done much to contribute to our current understanding of crown fire behavior through laboratory experiments, outdoor experimental burning, numerical modeling, and wildfire case histories (box 10), as well as operational experiences (e.g., Rothermel 1991c, 1998). See, for example, the selected case study summaries given in Pyne et al. (1996, pp. 82-89). Although operational fire behavior specialists have also made substantial case study contributions (e.g., Beighley and Bishop 1990, Miller et al. 2009, Murphy et al. 2007, Thomas 1991), valuable information and insights are not being captured in a systematic way. McAlpine and Wotton (2009) have outlined one possible way in the form of a “fire behavior knowledge base.”

Various attempts have been made over the years to monitor and document high-intensity fire behavior (Alexander and Taylor 2010, Vaillant and Fites-Kaufman 2009), but what is required is a permanently staffed, ongoing effort. Alexander (2002) has in fact suggested that there is a need to create operational fire behavior research units specifically for this purpose. The efforts made by fire researchers and

Box 10:

Useful Links to Further Information

U.S. Fire Modeling Systems

- <http://firelab.org/applications>

Canadian Forest Fire Danger Rating System

- <https://www.frames.gov/cffdrs/applied-fire-behavior/canadian-forest-fire-danger-rating-system/>
- http://cwfis.cfs.nrcan.gc.ca/en_CA/background/summary/fdr

Crown Fire Initiation and Spread System

- <http://www.frames.gov/cfis/>

International Crown Fire Modeling Experiment

- <https://www.frames.gov/icfme>
- <http://www.youtube.com/watch?v=FYup7cYKE3w>
- http://www.youtube.com/watch?v=zvPa_yEEd4E

Joint Fire Science Program Crown Fire Behavior Synthesis Project

- <http://www.fs.fed.us/wwetac/projects/alexander.html>

Fire Management Deep Smarts Project: Learning From the Experts

- <http://wildlandfireleadership.blogspot.ca/2012/01/leading-from-experts.html>

Fire Management Today

- http://www.fs.fed.us/fire/fmt/fmt_pdfs/FMT73-4.pdf

Canadian Fire Behaviour Knowledge Base

- <http://fbkb.ca/>

2002 Hayman Fire, Colorado

- <http://www.fs.fed.us/rmrs/presentations/hayman-fire-symposium/>

Crown Fire Behavior Characteristics and Prediction in Conifer Forests: A State of Knowledge Synthesis

- <http://www.fs.fed.us/wwetac/projects/alexander.html>

Box 10: continued

Applied Wildland Fire Behavior Research and Development

- https://www.frames.gov/applied_fire_behavior

Fire on Earth: An Introduction

- www.wiley.com/go/scott/fireonearth

fire weather meteorologists of the country in the 1950s and 1960s (DeCoste and Sackett 1966, Sackett and DeCoste 1967, Schaefer 1961, Small 1957) were unfortunately not sustained beyond the early 1970s (Chandler 1976). However, recent advances in all aspects of the technology associated with monitoring and documenting high-intensity wildfires have gradually made the task easier (e.g., Gilles 2011).

The continuance of basic research into fire fundamentals is essential to gaining a complete understanding of the physical processes involved in crown fire dynamics (Clark et al. 1999, Coen et al. 2004, Cohen 2004, McRae and Ji-zhong 2004, Radke et al. 2000), but scientific knowledge alone will not be enough to develop a complete picture of crown fire dynamics. There is still an overriding need to bolster the efforts in observing crown fire behavior and completing the necessary case study documentation (Alexander and Thomas 2003a, 2003b) in order to evaluate new and existing predictive models of crown fire behavior (box 11). Such a program should be regarded as a shared responsibility between wildland fire research and fire management and be considered part and parcel of adaptive management (Alexander and Taylor 2010).

Case study knowledge will prove a useful complement to fire behavior modeling and experienced judgment when it comes to appraising potential crown fire behavior (Alexander 2007b, 2009a; Alexander and Thomas 2003a, 2003b) as illustrated, for example, by Rothermel (2000). However, one still needs to be wary of properly interpreting observations of extreme fire behavior (Alexander 2009b).

Box 11:**On Validating Fire Models (From Watts 1987)**

“To many, computer models are the proverbial “black box” – we put something in and we get something else back out. Our confidence in the output may be solely a function of the reputation of the modeler. We may recognize the need to understand the important and fundamental principles involved, but there may not be time to work through all the aspects of the model. Validation should be rigorously pursued despite time and economic constraints, however, because, it is a vital link between science and its application.

Yet if validation is a process for determining that the outputs of a model conform to reality, no model can be validated in an absolute sense; i.e., a model can never be proved correct, it can only be proved wrong. Acceptance of a model does not imply certainty, but rather a sufficient degree of belief to justify further action. Thus, in practice, validating a fire model is really a problem of invalidation. The more difficult it is to invalidate the model, the more confidence we have in it. To increase our confidence we can subject the model to tests and comparisons designed to reveal where it fails. One approach used to validate models ... is to compare the results to those of another model in which one already has great confidence.

Correct “invalidation” of a fire model is also difficult. The fire modeler is working in an area in which relations among important variables are not precisely known. To build a model, many aspects of the real world must be aggregated or simplified. Simplifications are introduced for analytical or computational convenience or sometimes as a compromise to the cost of gathering data. Documentation should clearly state what has been assumed and what sort of uncertainty or bias the assumption is likely to introduce in the model output. It should also be made clear how the aggregations and simplifications restrict the types of predictions the model can and cannot make.”

Watts (1987) comments echo an earlier statement by Box (1979) who stated that “All models are wrong, some are useful.”

Future Outlook

In discussing his dichotomous key for appraising crowning potential (table 9-2), Fahnestock (1970) indicated that “No technique is available for calculating the mathematical probability that a fire will crown under given conditions.” In turn, Kerr et al. (1971) considered that “In the foreseeable future, there is little prospect of predicting the behavior of a fast-spreading crown fire in timber over any extended period of time.” More recently, Agee (1993) stated, “The chances of firebrand spotting and crown fires can be estimated, but the behavior of crown fire is still relatively unpredictable.” In light of these comments, obviously much has been accomplished and experienced in the past 20 to 40 years when viewed from the point of our current understanding and predictive capability with respect to crown fires (box 12).

Presumably, the future holds the same promise as the recent past provided we are willing to readily admit what we know and more importantly what we presumably still do not know about crown fires with respect to their environment, characteristics, and prediction. Several knowledge gaps have been alluded to throughout this summary. Furthermore, many basic wildland fire behavior research needs identified some 30 years ago, some of which are relevant to crown fires, have yet to be addressed (e.g., Albini 1984, 1997; Alexander and Andrews 1989; Van Wagner 1985). As Cohen (1990) has pointed out, research must be directed at both the operational products desired by fire and fuel managers, and the fundamental understanding that forms the basis for such end-user tools (box 13). Research into the prediction of crown fire behavior with respect to the safety of the general public and firefighters might be regarded as the very “raison d’être” (i.e., reason or justification for existence) for wildland fire research (Alexander 2007a).

Further discoveries and advancements in understanding of crown fire dynamics in conifer forests will require a dedication in time, money, and staff (Blatchford 1972). While basic or fundamental fire research should continue to be pursued (Finney et al. 2013), we also need to “promote studies that critically analyze and synthesize our existing knowledge” (Trevitt 1989). In actual fact, a comprehensive synthesis on crown fire behavior has been underway

Box 12:

Crown Fire Dynamics in Conifer Forests—A Summary of the Salient Points

Types of Crown Fires

Three kinds or classes of crown fire are recognized according to their degree of dependence on the surface phase of fire spread (i.e., passive, active, and independent, although the latter is generally regarded as a rare and short-lived occurrence).

Crown Fire Initiation

The amount of heat energy required in the form of convection and radiation to induce the onset of crowning is dictated by the canopy base height and foliar moisture content as manifested in the surface fire's intensity. A rather abrupt increase in fire activity should normally be expected as a fire transitions from the surface to crown fire phase.

Crown Fire Propagation

Whether a passive or active crown fire develops following the onset of crowning depends on the spread rate after initial crown combustion and is in turn related to canopy bulk density. A minimum value of about 0.1 kg/m^3 appears to represent a critical threshold for active crowning.

Crown Fire Rate of Spread

At a minimum, a doubling or tripling in a fire's rate of advance follows the onset of crowning. Wind-driven crown fires have been documented to spread at up to 100 m/min for several hours and in excess of 200 m/min for up to an hour. Although the mechanical effect of slope steepness on increasing a fire's rate of spread is well known, fires in mountainous terrain generally do not spread nearly as far for a given period of time compared to those on flat topography.

Crown Fire Intensity and Flame Zone Characteristics

As a result of the increase in spread rate and fuel available for combustion, a fire can easily

quadruple its intensity in a matter of seconds when crowning takes place (e.g., from 3,000 to 12,000 kW/m). The resulting wall of flame, standing nearly erect, is on average up to two to three times the tree height and emits fierce levels of radiation. Flame fronts commonly exceed 30 to 45 m in depth.

Crown Fire Area and Perimeter Growth

The area burned by a crown fire is at least four to nine times greater than that of a surface fire for the same period of time. Assuming unlimited horizontal fuel continuity, crown fires are capable of burning an area upwards of 70 000 ha with a perimeter length of 160 km in a single burning period and have done so in the past.

Crown Fire Spotting Activity

Crown fires commonly display high-density, short-range spotting (<50 m). Spotting distances of up to about 2.0 km, although less common, are frequently seen on crown fires, resulting in normal barriers to fire spread being breached. Many spot fires are simply overrun by the main advancing flame front of a crown fire before they effectively contribute to an increase in the fire's overall rate of advance. Cases of long-distance spotting in excess of 10 km have been reported.

Models, Systems, and Other Decision Aids for Predicting Crown Fire Behavior

The current set of guides and decision support systems for assessing potential crown fire behavior used in the United States do require considerable adjustment on the part of trained and informed users (e.g., fire behavior analysts, long-term fire analysts) for proper application. Alternative models and systems that have undergone far more extensive testing and requiring a minimum of inputs are available.

Implications for Fire and Fuel Management

Operational fire management personnel can readily help themselves when it comes to being able to assess crown fire behavior by increasing the amount of wildfire monitoring and case study documentation.

Box 13:**The Wildland Fire Behavior Prediction Paradox**

Rothermel (1987) has articulated the perpetual challenge faced by wildland fire behavior model developers in meeting the present and future needs of fire practitioners:

“... experience shows that predicting fire behavior is not easy and that the fire prediction systems and their models are not perfect. Users who want more accuracy urge us to include additional features such as methods for accounting for nonuniform fuels, or description of nonsteady fire behavior. In contrast, those who believe the system is too complicated would like a bare-bones product that anyone can pick up and learn to use quickly. Viewing this situation and attempting to serve these needs leads to the paradox:

- The models and systems aren't accurate enough.
- The models and systems are too complicated.
- The resolution of either one of these problems worsens the other.”

Rothermel (1987) suggested that the best example of this increased complexity was in the fine dead fuel moisture model produced by Rothermel and others (1986). The primary aim was to increase the accuracy of the moisture content predictions. The result was a better model but at least 52 separate factors influencing fine, dead fuel moisture content were identified as being required.

Presumably what is required at the field level are crude but reliable models or decision aids for predicting wildland fire behavior.

(Alexander 2011, 2014; Alexander et al. 2012a, 2013), new research into the complexities of crown fire phenomenology has already been initiated (Cohen et al. 2006, Cruz and Alexander 2009), and allied studies completed (e.g., Cruz and Alexander 2013, Cruz et al. 2014). We should not lose sight of the fact that “The prediction of surface fire behavior is, in fact, probably more difficult than the prediction of crowning potential, because of the multiplicity of possible forest floor and understory fuel complexes” (Van Wagner 1979a).

In the long run, scientific investigations into crown fire behavior might be best accomplished in the form of a collaborative, international or global research, development, and application effort (Christensen et al. 2007, McCaw and Alexander 1994, Weber 1995). Networked, multidisciplinary teams that can build on extant understanding while creating new knowledge regarding the mechanisms associated with crown fire initiation and spread may provide the necessary platform.

Literature Cited

Affleck, D.L.R.; Keyes, C.R.; Goodburn, J.M. 2012.

Conifer crown fuel modeling: current limits and potential for improvement. *Western Journal of Applied Forestry*. 27: 165–169.

Agca, M.; Popescu, S.C.; Harper, C.W. 2011.

Deriving forest canopy fuel parameters for loblolly pine forests in eastern Texas. *Canadian Journal of Forest Research*. 41: 1618–1625.

Agee, J.K. 1993. *Fire ecology of Pacific Northwest Forests*.

Washington, D.C: Island Press. 493 p.

Agee, J.K. 1996. The influence of forest structure on

fire behavior. In: Sherlock, J., ed. *Proceedings of the 17th annual forest vegetation management conference*. Redding, CA: Forest Vegetation Management Conference: 52–57.

Agee, J.K.; Skinner, C.N. 2005. Basic principles of

forest fuel reduction treatments. *Forest Ecology and Management*. 211: 83–96.

- Agee, J.K.; Wright, C.S.; Williamson, N.; Huff, M.H. 2002.** Foliar moisture content of Pacific Northwest vegetation and its relation to wildland fire behavior. *Forest Ecology and Management*. 167: 57–66.
- Ager, A.A.; Vaillant, N.M.; Finney, M.A. 2011.** Integrating fire behavior models and geospatial analysis for wildland fire risk assessment and fuel management planning. *Journal of Combustion*. 2011: Article ID 572452.
- Albini, F.A. 1976a.** Computer-based models of wildland fire behavior: a users' manual. Ogden, UT: U.S. Department of Agriculture, Forest Service, Intermountain Forest and Range Experiment Station. 68 p.
- Albini, F.A. 1976b.** Estimating wildland fire behavior and effects. Gen. Tech. Rep. INT-30. Ogden, UT: U.S. Department of Agriculture, Forest Service, Intermountain Forest and Range Experiment Station. 92 p.
- Albini, F.A. 1979.** Spot fire distance from burning trees—a predictive model. Gen. Tech. Rep. INT-56. Ogden, UT: U.S. Department of Agriculture, Forest Service, Intermountain Forest and Range Experiment Station. 73 p.
- Albini, F.A. 1981a.** Spot fire distance from isolated sources—extensions of a predictive model. Res. Note INT-309. Ogden, UT: U.S. Department of Agriculture, Forest Service, Intermountain Forest and Range Experiment Station. 9 p.
- Albini, F.A. 1981b.** A model for wind-blown flame from a line fire. *Combustion and Flame*. 43: 155–174.
- Albini, F.A. 1983a.** Potential spotting distance from wind-driven surface fires. Res. Pap. INT-309. Ogden, UT: U.S. Department of Agriculture, Forest Service, Intermountain Forest and Range Experiment Station. 27 p.
- Albini, F.A. 1983b.** Transport of firebrands by line thermals. *Combustion Science and Technology*. 32: 277–288.
- Albini, F.A. 1983c.** Wind flow into a model forest re-examined. In: Preprint volume of seventh conference on fire and forest meteorology. Boston, MA: American Meteorological Society: 115–122.
- Albini, F.A. 1984.** Wildland fires. *American Scientist*. 72: 590–597.
- Albini, F.A. 1993.** Dynamics and modelling of vegetation fires: observations. In: Crutzen, P.J.; Goldammer, J.G., eds. *Fire in the environment: the ecological, atmospheric, and climatic importance of vegetation fires*. Environ. Sci. Res. Rep. 13. Chichester, England: John Wiley & Sons: 39–52.
- Albini, F.A. 1996.** Iterative solution of the radiation transport equations governing spread of fire in wildland fuel. *Combustion, Explosion, and Shock Waves*. 32: 534–543.
- Albini, F.A. 1997.** An overview of research on wildland fire. In: Hasemi, Y., ed. *Fire safety science—proceedings of the fifth international symposium*. Melbourne, Victoria: International Association of Fire Safety Science: 59–74.
- Albini, F.A.; Alexander, M.E.; Cruz, M.G. 2012.** A mathematical model for predicting the maximum potential spotting distance from a crown fire. *International Journal of Wildland Fire*. 21: 609–627.
- Albini, F.A.; Baughman, R.G. 1979.** Estimating windspeeds for predicting wildland fire behavior. Res. Pap. INT-221. Ogden, UT: U.S. Department of Agriculture, Forest Service, Intermountain Forest and Range Experiment Station. 12 p.
- Albini, F.A.; Stocks, B.J. 1986.** Predicted and observed rates of spread of crown fire in immature jack pine. *Combustion Science and Technology*. 48: 65–76.
- Alexander, M.E. 1982.** Calculating and interpreting forest fire intensities. *Canadian Journal of Botany*. 60: 349–357.
- Alexander, M.E. 1983.** Analysis of the Canadian Forest Fire Weather Index for the 1968 Lesser Slave Lake Fire. Edmonton, AB: Environment Canada, Canadian Forestry Service, Northern Forest Research Centre. Forestry Report. 28: 8–10.

- Alexander, M.E. 1985.** Estimating the length-to-breadth ratio of elliptical forest fire patterns. In: Donoghue, L.R.; Martin, R.E., eds. Proceedings of eighth conference on fire and forest meteorology. SAF Publ. 85-04. Bethesda, MD: Society of American Foresters: 287–304.
- Alexander, M.E. 1988.** Help with making crown fire hazard assessments. In: Fischer, W.C.; Arno, S.F., comps. Proceedings of symposium and workshop on protecting people and homes from wildfire in the interior West. Gen. Tech. Rep. INT-251. Ogden, UT: U.S. Department of Agriculture, Forest Service, Intermountain Research Station: 147–156.
- Alexander, M.E. 1991.** The 1985 Butte Fire in central Idaho: a Canadian perspective on the associated burning conditions. In: Nodvin, S.C.; Waldrop, T.A., eds. Proceeding of the international symposium on fire and the environment: ecological and cultural perspectives. Gen. Tech. Rep. SE-69. Asheville, NC: U.S. Department of Agriculture, Forest Service, Southeastern Forest Experiment Station: 334–343.
- Alexander, M.E. 1992a.** Fire behaviour in exotic pine plantations in Australia. Australian Forest Grower. 15(1): 20.
- Alexander, M.E. 1992b.** The 1990 Stephen Bridge Road Fire: a Canadian perspective on the fire danger conditions. Wildfire News and Notes. 6(1): 6.
- Alexander, M.E. 1998.** Crown fire thresholds in exotic pine plantations of Australasia. Canberra, ACT: Australian National University. 228 p. Ph.D. thesis.
- Alexander, M.E. 2000a.** Fire behaviour as a factor in forest and rural fire suppression. For. Res. Bull. No. 197, For. Rural Fire Sci. Tech. Ser. Rep. No. 5. Rotorua and Wellington, New Zealand: Forest Research in association with New Zealand Fire Service Commission and National Rural Fire Authority. 28 p.
- Alexander, M.E. 2000b.** The Mann Gulch Fire and the Canadian Forest Fire Danger Rating System. In: Preprints of third AMS symposium on fire and forest meteorology. Boston, MA: American Meteorological Society: 97–98.
- Alexander, M.E. 2002.** The staff ride approach to wildland fire behavior and firefighter safety. Fire Management Today. 62(4): 25–30.
- Alexander, M.E. 2004.** What triggered the Brewer Fire blowup remains the mystery. Fire Management Today. 64(2): 56–57.
- Alexander, M.E. 2005.** Long-term experiment takes some of the mystery out of crown fires. Fire Management Today. 65(3): 36–37.
- Alexander, M.E. 2006.** Models for predicting crown fire behavior—a review. In: V short course on fire behaviour. Coimbra, Portugal: Association for the Development of Industrial Aerodynamics, Forest Fire Research Centre: 173–225. www.frames.gov/documents/catalog/alexander_2006b.pdf. (21 May 2011).
- Alexander, M.E. 2007a.** Improving wildland firefighter and public safety through fire behavior research and development. Fire Management Today. 67(1): 49–50.
- Alexander, M.E. 2007b.** Simple question; difficult answer: how much fuel is acceptable? Fire Management Today. 67(3): 6–11.
- Alexander, M.E. 2008.** Proposed revision of fire danger class criteria for forest and rural areas of New Zealand. 2nd ed. Christchurch and Wellington, New Zealand: National Rural Fire Authority in association with the Scion Rural Fire Research Group. 62 p.
- Alexander, M.E. 2009a.** The 1988 fires of Yellowstone and beyond as a wildland fire behavior case study. Tucson, AZ: U.S. Department of Agriculture, Forest Service, Wildland Fire Lessons Learned Center. 30 p. www.nwccweb.us/content/products/past/publications/Alexander_yellowstone88_FB.pdf. (3 February 2010).
- Alexander, M.E. 2009b.** Wildland fire behavior and “The Course of Science” flowchart: is there a connection? Fire Management Today. 69(3): 44–46.
- Alexander, M.E. 2009c.** Are we abusing our use of models and modelling in wildland fire and fuel management? Fire Management Today. 69(4): 24–27.

- Alexander, M.E. 2010a.** Foliar moisture content input in the Canadian Forest Fire Behavior Prediction System for areas outside of Canada. In: Viegas, D.X. ed. Proceedings of the 6th international conference on forest fire research. [CD-ROM]. Coimbra, Portugal: University of Coimbra. 13 p.
- Alexander, M.E. 2010b.** Surface fire spread potential in trembling aspen during the summer in the boreal forest region of Canada. *Forestry Chronicle*. 86: 200–212.
- Alexander, M.E. Issue Coord. 2014.** Synthesis on crown fire behavior in conifer forests. *Fire Management Today* 73(4): 1-50.
- Alexander, M.E. 2011.** A synthesis on crown fires in conifer forests is underway. *Fire Management Today*. 71(1): 36.
- Alexander, M.E. issue coord. 2014.** Synthesis on crown fire behavior in conifer forests. *Fire Management Today*. 73(4): 1–50.
- Alexander, M.E.; Ackerman, M.Y.; Baxter, G.J. 2009.** An analysis of Dodge’s escape fire on the 1949 Mann Gulch Fire in terms of a survival zone for wildland firefighters. In: Proceedings of 10th wildland fire safety summit. [CD-ROM]. Birmingham, AL: International Association of Wildland Fire. 27 p.
- Alexander, M.E.; Andrews, P.L. 1989.** Wildland fire occurrence and behavior analysis in the year 2000 and beyond. *Fire Management Notes*. 50(4): 35–37.
- Alexander, M.E.; Cole, F.V. 1995.** Predicting and interpreting fire intensities in Alaskan black spruce forests using the Canadian system of fire danger rating. In: Managing forests to meet people’s needs: proceedings of 1994 Society of American Foresters/Canadian Institute of Forestry convention. SAF Publ. 95-02. Bethesda, MD: Society of American Foresters: 185–192.
- Alexander, M.E.; Cole, F.V. 2001.** Rating fire danger in Alaska ecosystems: CFFDRS provides an invaluable guide to systematically evaluating burning conditions. *Fireline*. 12(4): 2–3.
- Alexander, M.E.; Cruz, M.G. 2006.** Evaluating a model for predicting active crown fire rate of spread using wildfire observations. *Canadian Journal of Forest Research*. 36: 3015–3028.
- Alexander, M.E.; Cruz, M.G. 2009.** Recent advances in modelling the onset of crowning and crown fire rate of spread [extended abstract]. In: Masters, R.E.; Galley, K.E.M.; Despain, D.G., eds. The ’88 fires: Yellowstone and beyond. Tall Timbers Misc. Publ. No. 16. Tallahassee, FL: Tall Timbers Research Station: 19.
- Alexander, M.E.; Cruz, M.G. 2010.** Introducing the Canopy Fuel Stratum Characteristics Calculator. In: Wade, D.D.; Robinson, M.L., eds. Proceedings of the 3rd fire behavior and fuels conference. [CD-ROM]. Birmingham, AL: International Association of Wildland Fire. 6 p.
- Alexander, M.E.; Cruz, M.G. 2011a.** What are the safety implications of crown fires? In: Fox, R.L., ed. Proceedings of 11th wildland fire safety summit. [CD-ROM]. Missoula, MT: International Wildland Fire. 15 p.
- Alexander, M.E.; Cruz, M.G. 2011b.** Crown fire dynamics in conifer forests. In: Werth, P.A.; Potter, B.E.; Clements, C.B.; Finney, M.A.; Goodrich, S.L.; Alexander, M.E.; Cruz, M.G.; Forthafter, J.A.; McAllister, S.S. Synthesis of knowledge of extreme fire behavior: volume 1 for fire managers. Gen. Tech. Rep. PNW-GTR-854. Portland, OR: U.S. Department of Agriculture, Forest Service, Pacific Northwest Research Station: 107–142. Chapter 8
- Alexander, M.E.; Cruz, M.G. 2012a.** Interdependencies between flame length and fireline intensity in predicting crown fire initiation and lethal crown scorch height. *International Journal of Wildland Fire*. 21: 95–113.

- Alexander, M.E.; Cruz, M.G. 2012b.** Graphical aids for visualizing Byram's fireline intensity in relation to flame length and crown scorch height. *Forestry Chronicle*. 88: 185–190.
- Alexander, M.E.; Cruz, M.G. 2012c.** Modelling the impacts of surface and crown fire behaviour on serotinous cone opening in jack pine and lodgepole pine forests. *International Journal of Wildland Fire*. 21: 709–721.
- Alexander, M.E.; Cruz, M.G. 2013a.** Are the applications of wildland fire behaviour models getting ahead of their evaluation again? *Environmental Modelling and Software*. 41: 65–71.
- Alexander, M.E.; Cruz, M.G. 2013b.** Limitations on the accuracy of model predictions of wildland fire behaviour: a state-of-the-knowledge overview. *Forestry Chronicle*. 89: 370–381.
- Alexander, M.E.; Cruz, M.G. 2013c.** Assessing the effect of foliar moisture on the spread rate of crown fires. *International Journal of Wildland Fire*. 22: 415–427, 869–870.
- Alexander, M.E.; Cruz, M.G. 2014.** Tables estimating canopy fuel characteristics from stand variables in four interior west conifer forest types. *Forest Science*. 60: 784–794.
- Alexander, M.E.; Cruz, M.G.; Lopes, A.M.G. 2006.** CFIS: a software tool for simulating crown fire initiation and spread. In: Viegas, D.X., ed. *Proceedings of 5th international conference on forest fire research*. [CD-ROM]. Amsterdam, The Netherlands: Elsevier BV. 13 p.
- Alexander, M.E.; Cruz, M.G.; Vaillant, N.M.; Peterson, D.L. 2013.** Crown fire behavior characteristics and prediction in conifer forests: a state-of-knowledge synthesis. JFSP 09-S-03-1 Final Report. Joint Fire Science Program, Boise, ID. 39 p.
- Alexander, M.E.; Cruz, M.G.; Vaillant, N.M. 2012a.** Crown fires in conifer forests of the world: Do you have something to contribute or would you like to know about something? In: Spano, D.; Bacciu, V.; Salis, M.; Sirca, C., eds. *Modelling fire behaviour and risk*. Sassari, Italy: University of Sassari: 160–165.
- Alexander, M.E.; Cruz, M.G.; Vaillant, N.M.; Peterson, D.L. 2013.** Crown fire behavior characteristics and prediction in conifer forests: a state-of-knowledge synthesis. JFSP 09-S-03-1 final report. Boise, ID. Joint Fire Science Program. 39 p.
- Alexander, M.E.; De Groot, W.J. 1988.** Fire behavior in jack pine stands as related to the Canadian Forest Fire Weather Index (FWI) System. [Poster with text]. Edmonton, AB: Government of Canada, Canadian Forestry Service, Northern Forestry Centre. <http://cfs.nrcan.gc.ca/pubwarehouse/pdfs/24310.pdf> (15 March 2013).
- Alexander, M.E.; Lanoville, R.A. 1987.** Wildfires as a source of fire behavior data: a case study from Northwest Territories, Canada. In: *Conference papers of ninth conference on fire and forest meteorology*. Boston, MA: American Meteorological Society: 86–93.
- Alexander, M.E.; Lanoville, R.A. 1989.** Predicting fire behavior in the black spruce-lichen woodland fuel type of western and northern Canada. [Poster with text.] Edmonton, AB and Fort Smith, NT: Forestry Canada, Northern Forestry Centre and Government of Northwest Territories, Department of Renewable Resources, Territorial Forest Fire Centre. <http://cfs.nrcan.gc.ca/pubwarehouse/pdf/23093.pdf>. (15 March 2013).
- Alexander, M.E.; Mutch, R.W.; Davis, K.M.; Bucks, C.M. 2012b.** Wildland fires: dangers and survival. In: Auerbach, P.S., ed. *Wilderness medicine*. 6th ed. Philadelphia, PA: Elsevier: 240–280.
- Alexander, M.E.; Pearce, H.G. 1992.** Follow-up to the Spokane area firestorm '91 report: what were the Canadian fire danger indices? *Wildfire News and Notes*. 6(4): 6–7.

- Alexander, M.E.; Quintilio, D. 1990.** Perspectives on experimental fires in Canadian forestry research. *Mathematical and Computer Modelling*. 13(12): 17–26.
- Alexander, M.E.; Stam, J.C. 2003.** Safety alert for wildland firefighters: fuel conditions in spruce-beetle-killed forests. *Fire Management Today*. 63(2): 25.
- Alexander, M.E.; Steffner, C.N.; Mason, J.A.; Stocks, B.J.; Hartley, G.R.; Maffey, M.E.; Wotton, B.M.; Taylor, S.W.; Lavoie, N.; Dalrymple, G.N. 2004.** Characterizing the jack pine-black spruce fuel complex of the International Crown Fire Modelling Experiment (ICFME). Inf. Rep. NOR-X-393. Edmonton, AB: Natural Resources Canada, Canadian Forest Service, Northern Forestry Centre. 49 p.
- Alexander, M.E.; Stocks, B.J.; Lawson, B.D. 1991.** Fire behavior in black spruce-lichen woodland: the Porter Lake project. Inf. Rep. NOR-X-310. Edmonton, AB: Forestry Canada, Northern Forestry Centre. 44 p.
- Alexander, M.E.; Stocks, B.J.; Wotton, B.M.; Lanoville, R.A. 2001.** Tracking the spread and intensity of crown fires. *Initial Attack*. (Fall): 8–11.
- Alexander, M.E.; Taylor, S.W. 2010.** Wildland fire behavior case studies and the 1938 Honey Fire controversy. *Fire Management Today*. 70(1): 15–25.
- Alexander, M.E.; Thomas, D.A. 2003a.** Wildland fire behavior case studies and analyses: other examples, methods, reporting standards, and some practical advice. *Fire Management Today*. 63(4): 4–12.
- Alexander, M.E.; Thomas, D.A. 2003b.** Wildland fire behavior case studies and analyses: value, approaches, and practical uses. *Fire Management Today*. 63(3): 4–8.
- Alexander, M.E.; Thomas, D.A. 2004.** Forecasting wildland fire behavior: aids, guides, and knowledge-based protocols. *Fire Management Today*. 64(1): 4–11.
- Alexander, M.E.; Tymstra, C.; Frederick, K.W. 2004.** Incorporating breaching and spotting considerations into *PROMETHEUS*—the Canadian wildland fire growth model. Chisholm/Dogrib Fire Res. Initiative Quicknote 6. Hinton, AB: Foothills Model Forest. 2 p.
- Amiro, B.D.; Stocks, B.J.; Alexander, M.E.; Flannigan, M.D.; Wotton, B.M. 2001.** Fire, climate change, carbon and fuel management in the Canadian boreal forest. *International Journal of Wildland Fire*. 10: 405–413.
- Anderson, H.E. 1968.** Sundance Fire: an analysis of fire phenomena. Res. Pap. INT-56. Ogden, UT: U.S. Department of Agriculture, Forest Service, Intermountain Forest and Range Experiment Station. 39 p.
- Anderson, H.E. 1982.** Aids to determining fuel models for estimating fire behavior. Gen. Tech. Rep. INT-122. Ogden, UT: U.S. Department of Agriculture, Forest Service, Intermountain Forest and Range Experiment Station. 22 p.
- Anderson, H.E. 1983.** Predicting wind-driven wild land fire size and shape. Res. Pap. INT-305. Ogden, UT: U.S. Department of Agriculture, Forest Service, Intermountain Forest and Range Experiment Station. 26 p.
- Andrews, P.L. 1980.** Testing the fire behavior model. In: Martin, R.E.; Edmonds, R.L.; Faulkner, D.A.; Harrington, J.B.; Fuquay, D.M.; Stocks, B.J.; Barr, S., eds. *Proceedings of sixth conference on fire and forest meteorology*. Washington, DC: Society of American Foresters: 70–77.
- Andrews, P.L. 1986.** BEHAVE: fire behavior prediction and fuel modeling system—BURN subsystem, Part 1. Gen. Tech. Rep. INT-194. Ogden, UT: U.S. Department of Agriculture, Forest Service, Intermountain Research Station. 130 p.
- Andrews, P.L. 2007.** BehavePlus fire modeling system: past, present, and future. In: *Proceedings of 7th symposium on fire and forest meteorological society*. Boston, MA: American Meteorological Society. 13 p. <http://ams.confex.com/ams/pdfpapers/126669.pdf>. (12 October 2009).
- Andrews, P.L. 2010.** Do you BEHAVE?—Application of the BehavePlus fire modeling system. In: Wade, D.D.; Robinson, M.L., eds. *Proceedings of 3rd fire behavior and fuels conference*. [CD-ROM]. Birmingham, AL: International Association of Wildland Fire. 17 p.

- Andrews, P.L. 2012.** Modeling wind adjustment factor and midflame wind speed for Rothermel's surface fire spread model. Gen. Tech. Rep. RMRS-GTR-266. Fort Collins, CO: U.S. Department of Agriculture, Forest Service, Rocky Mountain Research Station. 39 p.
- Andrews, P.L.; Bevins, C.D.; Seli, R.C. 2008.** BehavePlus fire modeling system, version 4.0: user's guide. Gen. Tech. Rep. RMRS-GTR-106WWW. Fort Collins, CO: U.S. Department of Agriculture, Forest Service, Rocky Mountain Research Station. 116 p.
- Andrews, P.L.; Chase, C.H. 1989.** BEHAVE: fire behavior prediction and fuel modeling system—BURN subsystem, Part 2. Gen. Tech. Rep. INT-260. Ogden, UT: U.S. Department of Agriculture, Forest Service, Intermountain Research Station. 93 p.
- Andrews, P.L.; Heinsch, F.A.; Schelvan, L. 2011.** How to generate and interpret fire characteristic charts for surface and crown fire behavior. Gen. Tech. Rep. RMRS-GTR-253. Fort Collins, CO: U.S. Department of Agriculture, Forest Service, Rocky Mountain Research Station. 40 p.
- Andrews, P.L.; Queen, L.P. 2001.** Fire modeling and information system technology. *International Journal of Wildland Fire*. 10: 343–352.
- Andrews, P.L.; Rothermel, R.C. 1982.** Charts for interpreting wildland fire behavior characteristics. Gen. Tech. Rep. INT-131. Ogden, UT: U.S. Department of Agriculture, Forest Service, Intermountain Forest and Range Experiment Station. 21 p.
- Angelova, Z.; Stow, D.A.; Kaiser, J.; Dennison, P.E.; Cova, T.J. 2010.** Integrating fire behavior and pedestrian mobility models to assess potential risk to humans from wildfires within the US-Mexico border zone. *Professional Geographer*. 62: 230–247.
- Archibald, D.J.; Luke, A.B.; Coneybeare, W.C. 1994.** Early summer prescribed fire in northern Ontario. Tech. Note TN-010. Timmins, ON: Ontario Ministry of Natural Resources, Northeast Science and Technology. 12 p.
- Barney, R.J.; Van Cleve, K.; Schlentner, R. 1978.** Biomass distribution and crown characteristics in two Alaskan *Picea mariana* ecosystems. *Canadian Journal of Forest Research*. 8: 36–41.
- Barrows, J.S. 1951.** Fire behavior in Northern Rocky Mountain forests. Stn. Pap. No. 29. Missoula, MT: U.S. Department of Agriculture, Forest Service, Northern Rocky Mountain Forest and Range Experiment Station. 103 p. + appendices.
- Beale, J.A.; Dieterich, J.H. 1963.** Crown fire problems in the Lake States. *Wisconsin Conservation Bulletin*. 28(1): 12–13.
- Beck, J.A.; Alexander, M.E.; Harvey, S.D.; Beaver, A.K. 2002.** Forecasting diurnal variation in fire intensity to enhance wildland firefighter safety. *International Journal of Wildland Fire*. 11: 173–182.
- Beighley, M.; Bishop, J. 1990.** Fire behavior in high-elevation timber. *Fire Management Notes*. 51(2): 23–28. [republished in: *Fire Management Today*. 63(4): 56–62: 2003.].
- Bell, R. 2012.** Forest fires in northern Canada. *Fire Ecology*. 8: 3–10.
- Berlad, A.L.; Lee, S.-L. 1968.** Long-range spotting. *Combustion and Flame*. 12: 172–174.
- Beverly, J.L.; Wotton, B.M. 2007.** Modelling the probability of sustained flaming: predictive value of fire weather index components compared with observations of site weather and fuel moisture conditions. *International Journal of Wildland Fire*. 16: 161–173.
- Bickford, N.K. 1972.** Burnett's disaster stoppers. *Wisconsin Conservation Bulletin*. 37(6): 22–23.
- Bilgili, E.; Methven, I.R. 1994.** A dynamic fuel model for use in managed even-aged stands. *International Journal of Wildland Fire*. 4: 177–185.
- Blatchford, A.N. 1972.** Dissemination and application of research information in the field. Res. Develop. Pap. 88. London, England: Forestry Commission. 5 p.

- Box, G.E.P. 1979.** Robustness in the strategy of scientific model building. In: Launer, R.L.; Wilkinson, G.N., eds. Robustness in statistics. New York: Academic Press: 201–239.
- Brose, P.H. 2009.** Photo guide for estimating fuel loading and fire behavior in mixed-oak forests of the mid-Atlantic region. Gen. Tech. Rep. NRS-45. Newton Square, PA: U.S. Department of Agriculture, Forest Service, Northern Research Station. 104 p.
- Brotak, E.A. 1979.** The Bass River Fire: weather conditions associated with a fatal fire. Fire Management Notes. 40(1): 10–13. [republished in: Fire Management Today 63(4): 25–28. 2003]
- Brown, A.A. 1937.** The factors and circumstances that led to the Blackwater Fire tragedy. Fire Control Notes. 1(6): 384–387. [republished in: Fire Management Today. 63(3): 11–14. 2003].
- Brown, A.A.; Davis, K.P. 1973.** Forest fire: control and use. 2nd ed. New York: McGraw-Hill. 686 p.
- Brown, A.A.; Folweiler, A.D. 1953.** Fire in the forests of the United States. 2nd ed. St. Louis, MO: J.S. Swift Co. Inc. 233 p.
- Bruner, A.D.; Klebenow, D.A. 1979.** Predicting success of prescribed fire in pinyon-juniper woodland in Nevada. Res. Pap. INT-219. Ogden, UT: U.S. Department of Agriculture, Forest Service, Intermountain Forest and Range Experiment Station. 12 p.
- Bryant, F.C.; Launchbaugh, G.K.; Koerth, B.H. 1983.** Controlling mature ash juniper in Texas with crown fires. Journal of Range Management. 36: 165–168.
- Buck, C.C. 1941.** Fire behavior in the forest fire research program. In: Proceedings of the Priest River Fire meeting. Washington, DC: U.S. Department of Agriculture, Forest Service: 66–72.
- Burgan, R.E. 1979.** Fire danger/fire behavior computations with the Texas Instruments TI-59 calculator: user's manual. Gen. Tech. Rep. INT-61. Ogden, UT: U.S. Department of Agriculture, Forest Service, Intermountain Forest and Range Experiment Station. 25 p.
- Burgan, R.E. 1987.** Concepts and interpreted examples in advanced fuel modeling. Gen. Tech. Rep. INT-238. Ogden, UT: U.S. Department of Agriculture, Forest Service, Intermountain Forest and Range Experiment Station. 40 p.
- Burgan, R.E. 1988.** 1988 revisions to the 1978 National Fire-Danger Rating System. Res. Pap. SE-273. Asheville, NC: U.S. Department of Agriculture, Forest Service, Southeastern Forest Experiment Station. 39 p.
- Burgan, R.E.; Rothermel, R.C. 1984.** BEHAVE: fire behavior prediction and fuel modeling system—FUEL subsystem. Gen. Tech. Rep. INT-167. Ogden, UT: U.S. Department of Agriculture, Forest Service, Intermountain Forest and Range Experiment Station. 106 p.
- Burrows, N.D. 1984.** Predicting blow-up fires in the jarrah forest. Tech. Pap. No. 12. Perth, Western Australia: Forests Department of Western Australia. 27 p.
- Burrows, N.D. 2001.** Flame residence times and rates of weight loss of eucalypt forest fuel particles. International Journal of Wildland Fire. 10: 137–143.
- Burrows, N.; Ward, B.; Robinson, A. 1988.** Aspects of fire behaviour and fire suppression in a *Pinus radiata* plantation. Landnote 2/88. Perth, Western Australia: Western Australia Department of Conservation and Land Management. 4 p.
- Burrows, N.; Ward, B.; Robinson, A. 1991.** Fire behaviour in spinifex fuels on the Gibson Desert Nature Reserve, Western Australia. Journal of Arid Environments. 20: 189–204.
- Butler, B.W.; Bartlette, R.A.; Bradshaw, L.S.; Cohen, J.D.; Andrews, P.L.; Putnam, T.; Mangan, R.J. 1998.** Fire behavior associated with the 1994 South Canyon Fire on Storm King Mountain, Colorado. Res. Pap. RMRS-RP-9. Ogden, UT: U.S. Department of Agriculture, Forest Service, Rocky Mountain Research Station. 82 p.

- Butler, B.W.; Cohen, J.D. 1998.** Firefighter safety zones: a theoretical model based on radiative heating. *International Journal of Wildland Fire*. 8: 73–77.
- Butler, B.W.; Cohen, J.; Latham, D.J.; Schuette, R.D.; Sopko, P.; Shannon, K.S.; Jimenez, D.; Bradshaw, L.S. 2004a.** Measurements of radiant emissive power and temperatures in crown fires. *Canadian Journal of Forest Research*. 34: 1577–1587.
- Butler, B.W.; Finney, M.A.; Andrews, P.L.; Albini, F.A. 2004b.** A radiation-driven model of crown fire spread. *Canadian Journal of Forest Research*. 34: 1588–1599.
- Butler, B.W.; Reynolds, T.D. 1997.** Wildfire case study: Butte City Fire, southeastern Idaho, July 1, 1994. Gen. Tech. Rep. INT-GTR-351. Ogden, UT: U.S. Department of Agriculture, Forest Service, Intermountain Research Station. 15 p.
- Byram, G.M. 1954.** Atmospheric conditions related to blowup fires. Stn. Pap. No. 35. Asheville, NC: U.S. Department of Agriculture, Forest Service, Southeastern Forest Experiment Station. 34 p.
- Byram, G.M. 1955.** Possible causes of blowup fires. In: *Modern forest fire management in the South*. Proceedings of the fourth annual forestry symposium. Baton Rouge, LA: Louisiana State University, School of Forestry: 24–34.
- Byram, G.M. 1957.** Some principles of combustion and their significance in forest fire behavior. *Fire Control Notes*. 18(2): 47–57. [republished as: *Fire Management Today* 64(1): 37–44. 2004].
- Byram, G.M. 1959a.** Combustion of forest fuels. In: Davis, K.P., ed. *Forest fire: control and use*. New York: McGraw-Hill: 61–89, 554–555.
- Byram, G.M. 1959b.** Forest fire behavior. In: Davis, K.P., ed. *Forest fire: control and use*. New York: McGraw-Hill: 90–123, 554–555.
- Call, P.T. 1997.** Run-time optimisation of radiation driven crown fire model. Bozeman, MT: Montana State University. 86 p. M.S. thesis.
- Call, P.T.; Albini, F.A. 1997.** Aerial and surface fuel consumption in crown fires. *International Journal of Wildland Fire*. 7: 259–264.
- Campbell, D. 2005.** *The Campbell Prediction System*. 3rd ed. Ojai, CA: Ojai Printing and Publishing Co. 142 p.
- Carlton, D. 2005.** *Fuels Management Analyst Plus* software, version 3. Estacada, OR: Fire Program Solutions LLC. <http://www.fireps.com/fmanalyst3/index.htm> (8 November 2009).
- Catchpole, E.A.; Alexander, M.E.; Gill, A.M. 1992.** Elliptical-fire perimeter- and area-intensity distributions. *Canadian Journal of Forest Research*. 22: 968–972. [Errata: 23(6):1244, 1993]; 29(6): 788, 1999].
- Catchpole, W.R. 1987.** *Heathland fuel and fire modelling*. Canberra, Australian Capital Territory: University of New South Wales, University College, Department of Mathematics. 271 p. Ph.D. thesis.
- Chandler, C.C. 1976.** Meteorological needs of fire danger and fire behavior. In: Baker, D.H.; Fosberg, M.A., tech. cords. *Proceedings of fourth national conference on fire and forest meteorology*. Gen. Tech. Rep. RM-32. Fort Collins, CO: U.S. Department of Agriculture, Forest Service, Rocky Mountain Forest and Range Experiment Station: 38–41.
- Chandler, C.; Cheney, P.; Thomas, P.; Trabaud, L.; Williams, D. 1983a.** *Fire in forestry. Volume I: forest fire behavior and effects*. New York: John Wiley & Sons. 450 p.
- Chandler, C.; Cheney, P.; Thomas, P.; Trabaud, L.; Williams, D. 1983b.** *Fire in forestry. Volume II: forest fire management and organization*. New York: John Wiley & Sons. 298 p.
- Chandler, C.C.; Storey, T.G.; Tangren, C.D. 1963.** Prediction of fire spread following nuclear explosions. Res. Pap. PSW-5. Berkeley, CA: U.S. Department of Agriculture, Forest Service, Pacific Southwest Forest and Range Experiment Station. 110 p.

- Cheney, N.P. 1968.** Predicting fire behaviour with fire danger tables. *Australian Forestry*. 32: 71–79.
- Cheney, N.P. 1981.** Fire behaviour. In: Gill, A.M.; Groves, R.H.; Noble, I.R., eds. *Fire and the Australian Biota*. Canberra, ACT: Australian Academy of Science: 151–175.
- Cheney, N.P.; Gould, J.S.; Catchpole, W.R. 1998.** Prediction of fire spread in grasslands. *International Journal of Wildland Fire*. 8: 1–13.
- Cheney, N.P.; Gould, J.S.; McCaw, W.L.; Anderson, W.R. 2012.** Predicting fire behaviour in dry eucalypt forest in southern Australia. *Forest Ecology and Management*. 280: 120–131.
- Cheney, P.; Sullivan, A. 2008.** *Grassfires: fuel, weather and fire behaviour*. 2nd ed. Melbourne, South Australia: CSIRO Publishing. 150 p.
- Childs, B.H. 1961.** Controlled burning to form a green-belt through Kaingaroa Forest. *New Zealand Journal of Forestry*. 8: 467–496.
- Christensen, N.L., chair; Alexander, M.E.; Benson, N.C.; Brown, T.J.; Cortner, H.J.; Omi, P.N.; Schmidt, R.G.; Shlisky, A.; Swallow, S.K. 2007.** U.S. Forest Service R&D wildland fire external peer review. Washington, DC: U.S. Department of Agriculture, Forest Service, Research and Development. 25 p.
- Chrosiewicz, Z. 1986a.** Foliar heat content variations in four conifer tree species of central Alberta. *Canadian Journal of Forest Research*. 16: 152–157.
- Chrosiewicz, Z. 1986b.** Foliar moisture content variations in four conifer tree species of central Alberta. *Canadian Journal of Forest Research*. 16: 157–162.
- Cionco, R.M. 1965.** A mathematical model for air flow in a vegetative canopy. *Journal of Applied Meteorology*. 4: 517–522.
- Clark, R.G. 1983.** Threshold requirements for fire spread in grasslands fuels. Lubbock, TX: Texas Tech University. 72 p. Ph.D. dissertation.
- Clark, T.L.; Radke, L.F.; Coen, J.L.; Middleton, D. 1999.** Analysis of small-scale convection dynamics in a crown fire using infrared video camera imagery. *Journal of Applied Meteorology*. 38: 1401–1420.
- Coen, J.; Mahalingam, S.; Daily, J. 2004.** Infrared imagery of crown-fire dynamics during FROSTFIRE. *Journal of Applied Meteorology*. 43: 1241–1255.
- Cohen, J.D. 1990.** Research has part of the answer. In: *Are forests the answer?* Proceedings of the 1990 Society of American Foresters national convention. SAF Publ. 90-02. Bethesda, MD: Society of American Foresters: 117–120.
- Cohen, J.D. 2004.** Relating flame radiation to home ignition using modeling and experimental crown fires. *Canadian Journal of Forest Research*. 34: 1616–1626.
- Cohen, J.D.; Finney, M.A.; Yedinak, K.M. 2006.** Active spreading crown fire characteristics: implications for modeling. In: Viegas, D.X., ed. *Proceedings of the 5th international conference on forest fire research*. [CD-ROM]. Amsterdam, The Netherlands: Elsevier BV. 12 p.
- Cohen, W.B. 1989.** Experiments designed to improve crown fire hazard assessment capabilities. Fort Collins, CO: Colorado State University. 194 p. Ph.D. dissertation.
- Cohen, W.B.; Omi, P.N.; Kaufmann, M.R. 1987.** Water uptake of subalpine conifer branches during heating. In: Troendle, C.A.; Kaufmann, M.R.; Hamre, R.H.; Winokur, R.P., tech. coords. *Proceedings of a technical conference—management of subalpine forests: building on 50 years of research*. Gen. Tech. Rep. RM-149. Fort Collins, CO: U.S. Department of Agriculture, Forest Service, Rocky Mountain Forest and Range Experiment Station: 207–210.
- Cohen, W.B.; Omi, P.N.; Kaufmann, M.R. 1990.** Heating-related water transport to intact lodgepole pine branches. *Forest Science*. 36: 246–254.

- Cohen, W.B.; Omi, P.N.; Rothermel, R.C. 1989.** Heating-related water transport in woody plants: summary of experimental results. In: MacIver, D.C.; Auld, H.; Whitewood, R., eds. Proceedings of the 10th conference on fire and forest meteorology. Ottawa, ON: Forestry Canada and Environment Canada: 413–415.
- Cole, F.; Alexander, M.E. 1995a.** Canadian fire danger rating system proves valuable tool in Alaska. *Fireline*. 8(3): 2–3.
- Cole, F.V.; Alexander, M.E. 1995b.** Head fire intensity class graph for FBP System Fuel Type C-2 (Boreal Spruce). [Poster with text.] Fairbanks, AK and Edmonton, AB: Alaska Department of Natural Resources, Division of Forestry and Natural Resources Canada, Canadian Forest Service. <http://cfs.nrcan.gc.ca/pubwarehouse/pdfs/24358.pdf>.
- Contreras, M.A.; Parsons, R.A.; Chung, W. 2012.** Modeling tree-level fuel connectivity to evaluate the effectiveness of thinning treatments for reducing crown fire potential. *Forest Ecology and Management*. 264: 134–149. <http://cfs.nrcan.gc.ca/pubwarehouse/pdfs/24358.pdf>.
- Countryman, C.M. 1964.** Mass fires and fire behavior. Res. Pap. PSW-19. Berkeley, CA: U.S. Department of Agriculture, Forest Service, Pacific Southwest Forest and Range Experiment Station. 53 p.
- Countryman, C.M. 1972.** The fire environment concept. Berkeley, CA: U.S. Department of Agriculture, Forest Service, Pacific Southwest Forest and Range Experiment Station. 12 p.
- Countryman, C.M. 1974.** Can southern California wildland conflagrations be stopped? Gen. Tech. Rep. PSW-7. Berkeley, CA: U.S. Department of Agriculture, Forest Service, Pacific Southwest Forest and Range Experiment Station. 11 p.
- Countryman, C.M.; Fosberg, M.A.; Rothermel, R.C. 1968.** Fire weather and fire behavior in the 1966 Loop Fire. *Fire Technology*. 4: 126–141.
- Countryman, C.M.; McCutchan, M.H.; Ryan, B.C. 1969.** Fire weather and fire behavior at the 1968 Canyon Fire. Res. Pap. PSW-55. Berkeley, CA: U.S. Department of Agriculture, Forest Service, Pacific Southwest Forest and Range Experiment Station. 20 p.
- Cronan, J.; Jandt, R. 2008.** How succession affects fire behavior in boreal black spruce forest of interior Alaska. BLM-Alaska Tech. Rep. 59. Anchorage, AK: U.S. Department of the Interior, Bureau of Land Management, Alaska State Office. 15 p.
- Crosby, J.S.; Chandler, C.C. 2004.** Get the most from your windspeed observation. *Fire Management Today*. 64(1): 53–55. [originally published as: *Fire Control Notes* 27(4): 12–13. 1966].
- Crosby, J.S.; Johansen, R.W.; Cooper, R.W. 1963.** A new machine for forest fire control: the Modell II Michigan sand caster. Res. Pap. CS-2. Columbus, OH: U.S. Department of Agriculture, Forest Service, Central States Forest Experiment Station. 30 p.
- Cruz, M.G. 1999.** Modeling the initiation and spread of crown fires. Missoula, MT: University of Montana. 162 p. M.S. thesis.
- Cruz, M.G. 2004.** Ignition of crown fuels above a spreading surface fire. Missoula, MT: University of Montana. 240 p. Ph.D. dissertation.
- Cruz, M.G. 2010.** Monte Carlo-based ensemble method for prediction of grassland fire spread. *International Journal of Wildland Fire*. 19: 521–530.
- Cruz, M.G.; Alexander, M.E. 2009.** Assessing discontinuous fire behaviour and uncertainty associated with the onset of crowning [extended abstract]. In: Masters, R.E.; Galley, K.E.M.; Despain, D.G., eds. The '88 fires: Yellowstone and beyond. Tall Timbers Misc. Publ. No. 16. Tallahassee, FL: Tall Timbers Research Station: 20.

- Cruz, M.G.; Alexander, M.E. 2010a.** Assessing crown fire potential in coniferous forests of western North America: a critique of current approaches and recent simulation studies. *International Journal of Wildland Fire*. 19: 377–398.
- Cruz, M.G.; Alexander, M.E. 2010b.** Crown fires. In: VI short course on fire behaviour. Coimbra, Portugal: Association for the Development of Industrial Aerodynamics, Forest Fire Research Centre, Coimbra, Portugal: 30–46. http://frames.nbii.gov/documents/catalog/cruz_and_alexander_2010.pdf. (27 December 2010).
- Cruz, M.G.; Alexander, M.E. 2012.** Evaluating regression model estimates of canopy fuel stratum characteristics in four crown fire prone fuel types in western North America. *International Journal of Wildland Fire*. 21: 168–179.
- Cruz, M.G.; Alexander, M.E. 2013.** Uncertainty associated with model predictions of surface and crown fire rates of spread. *Environmental Modelling and Software*. 47: 16–28.
- Cruz, M.G.; Alexander, M.E.; Fernandes, P.A.M. 2008.** Development of a model system to predict wildfire behaviour in pine plantations. *Australian Forestry*. 70: 113–121.
- Cruz, M.G.; Alexander, M.E.; Wakimoto, R.H. 2002.** Predicting crown fire behavior to support forest fire management decision-making. In: Viegas, D.X., ed. *Forest fire research and wildland fire safety*. [CD-ROM]. Rotterdam, Netherlands: Millpress Scientific Publishing. 11 p.
- Cruz, M.G.; Alexander, M.E.; Wakimoto, R.H. 2003a.** Assessing canopy fuel stratum characteristics in crown fire prone fuel types of western North America. *International Journal of Wildland Fire*. 12: 39–50.
- Cruz, M.G.; Alexander, M.E.; Wakimoto, R.H. 2003b.** Assessing the probability of crown fire initiation based on fire danger indices. *Forestry Chronicle*. 79: 976–983.
- Cruz, M.G.; Alexander, M.E.; Wakimoto, R.H. 2003c.** Definition of a fire behavior model evaluation protocol: a case study application to crown fire behavior models. In: Omi, P.N.; Joyce, L.A., tech. eds. *Fire, fuel treatments and ecological restoration: conference proceedings*. Proc. RMRS-P-29. Fort Collins, CO: U.S. Department of Agriculture, Forest Service, Rocky Mountain Research Station: 49–67.
- Cruz, M.G.; Alexander, M.E.; Wakimoto, R.H. 2004.** Modeling the likelihood of crown fire occurrence in conifer forest stands. *Forest Science*. 50: 640–658.
- Cruz, M.G.; Alexander, M.E.; Wakimoto, R.H. 2005.** Development and testing of models for predicting crown fire rate of spread in conifer forest stands. *Canadian Journal of Forest Research*. 35: 1626–1639.
- Cruz, M.G.; Alexander, M.E.; Wakimoto, R.H. 2010b.** Comment on “Estimating canopy fuel characteristics in five conifer stands in the western United States using tree and stand measurements.” *Canadian Journal of Forest Research*. 40: 2262–2263.
- Cruz, M.G.; Butler, B.W.; Alexander, M.E. 2006a.** Predicting the ignition of crown fuels above a spreading surface fire. Part II: Model behavior and evaluation. *International Journal of Wildland Fire*. 15: 61–72.
- Cruz, M.G.; Butler, B.W.; Alexander, M.E.; Forthofer, J.M.; Wakimoto, R.H. 2006b.** Predicting the ignition of crown fuels above a spreading surface fire. Part I: Model idealization. *International Journal of Wildland Fire*. 15: 47–60.
- Cruz, M.G.; Butler, B.W.; Alexander, M.E.; Viegas, D.X. 2006c.** Development and evaluation of a semi-physical crown fire initiation model. In: Viegas, D.X., ed. *Proceedings of the 5th international conference on forest fire research*. [CD-ROM]. Amsterdam, The Netherlands: Elsevier BV. 17 p.
- Cruz, M.G.; Fernandes, P.M. 2008.** Development of fuel models for fire behaviour in maritime pine (*Pinus pinaster* Ait.) stands. *International Journal of Wildland Fire*. 17: 194–204.

- Cruz, M.G.; Gould, J. 2009.** Field-based fire behaviour research: past and future roles. In: Anderssen, R.S.; Braddock, R.D.; Newham, L.T.H., eds. Proceedings of the 18th world IMACS congress and MODSIM09 international congress on modelling and simulation. Modelling and Simulation Society of Australia and New Zealand and International Association for Mathematics and Computers in Simulation: 247–253. <http://www.mssanz.org.au/modsim09/A4/cruz.pdf>. (14 February 2010).
- Cruz, M.G.; Gould, J. 2010.** Fire dynamics in mallee-heath. Fire Note Issue 66. East Melbourne, VIC. Bushfire Cooperative Research Centre. 4 p.
- Cruz, M.G.; Gould, J.S.; Alexander, M.E.; Sullivan, A.L.; McCaw, W.L.; Matthews, S. 2015.** A guide to rate of fire spread models for Australian vegetation. Rev. ed. Canberra, Australian Capital Territory and Melbourne, Victoria, Australia. CSIRO Land and Water Flagship and Australasian Fire Authorities Council. 125 p.
- Cruz, M.G.; Matthews, S.; Gould, J.; Ellis, P.; Henderson, M.; Knight, I.; Watters, J. 2010a.** Fire dynamics in mallee-heath: fuel, weather and fire behaviour prediction in south Australian semi-arid shrublands. Bushfire Coop. Res. Cent. Rep. No. 1.10.01. Canberra, ACT: CSIRO Sustainable Ecosystems. 134 p.
- Cruz, M.G.; McCaw, W.L.; Anderson, W.R.; Gould, J.S. 2012a.** Fire behaviour modelling in semi-arid mallee-heath shrublands of southern Australia. *Environmental Modelling and Software*. 40: 21–34.
- Cruz, M.G.; Sullivan, A.L.; Gould, J.S.; Sims, N.C.; Bannister, A.J.; Hollis, J.J.; Hurley, R. 2012b.** Anatomy of a catastrophic wildfire: the Black Saturday Kilmore East Fire. *Forest Ecology and Management*. 284: 269–285.
- Custer, G.; Thorsen, J. 1996.** Stand-replacement burn in the Ocala National Forest—a success. *Fire Management Notes*. 56(2): 7–12.
- Davis, J.B.; Chandler, C.C. 1965.** Vortex turbulence—its effect on fire behavior. *Fire Control Notes*. 26(1): 4–6, 16. [republished as: *Fire Management Today*. 64(1): 45–48. 2004].
- Davis, J.R.; Dieterich, J.H. 1976.** Predicting rate of fire spread (ROS) in Arizona oak chaparral: field workbook. Gen. Tech. Rep. RM-24. Fort Collins, CO: U.S. Department of Agriculture, Forest Service, Rocky Mountain Forest and Range Experiment Station. 8 p.
- DeBano, L.F.; Neary, D.G.; Ffolliott, P.F. 1998.** Fire effects on ecosystems. New York: John Wiley & Sons. 352 p.
- DeCoste, J.H.; Sackett, S.S. 1966.** Baptism by fire. *Southern Lumberman*. 213(2656): 169–170.
- DeCoste, J.H.; Wade, D.D.; Deeming, J.E. 1968.** The Gaston Fire. Res. Pap. SE-43. Asheville, NC: U.S. Department of Agriculture, Forest Service, Southeastern Forest Experiment Station. 36 p.
- Deeming, J.E.; Brown, J.K. 1975.** Fuel models in the National Fire-Danger Rating System. *Journal of Forestry*. 73: 347–350.
- Deeming, J.E.; Burgan, R.E.; Cohen, J.D. 1977.** The National Fire-Danger Rating System. Gen. Tech. Rep. INT-39. Ogden, UT: U.S. Department of Agriculture, Forest Service, Intermountain Forest and Range Experiment Station. 63 p.
- Deeming, J.E.; Lancaster, J.W.; Fosberg, M.A.; Furman, R.W.; Schroeder, M.J. 1972.** National Fire-Danger Rating System. Res. Pap. RM-84. Fort Collins, CO: U.S. Department of Agriculture, Forest Service, Rocky Mountain Forest and Range Experiment Station. 165 p.
- De Groot, W.J. 1993.** Examples of fuel types in the Canadian Forest Fire Behavior Prediction (FBP) System. [Poster with text.] Edmonton, AB: Forestry Canada, Northern Forestry Centre. <http://cfs.nrcan.gc.ca/pubwarehouse/pdfs/11038.pdf>. (15 March 2013).
- Despain, D.G.; Clark, D.L.; Reardon, J.J. 1996.** Simulation of crown fire effects on canopy seed bank in lodgepole pine. *International Journal of Wildland Fire*. 6: 45–49.

- Dickinson, J.; Robinson, A.; Harrod, R.; Gessler, P.; Smith, P. 2009.** Flatland in flames: a two-dimensional crown fire propagation model. *International Journal of Wildland Fire*. 18: 527–535.
- Dieterich, J.H. 1963.** Moisture content in live crowns. In: Annual report 1963. St. Paul, MN: U.S. Department of Agriculture, Forest Service, Lake States Forest Experiment Station: 36.
- Dieterich, J.H. 1976.** Jet stream influence on the Willow Fire. *Fire Management Notes*. 37(2): 6–8. [republished as: *Fire Management Today*. 63(4): 17–19. 2003].
- Dieterich, J.H. 1979.** Recovery potential of fire-damaged southwestern ponderosa pine. Res. Note RM-379. Fort Collins, CO: U.S. Department of Agriculture, Forest Service, Rocky Mountain Forest and Range Experiment Station. 8 p.
- Doren, R.F.; Richardson, D.R.; Roberts, R.E. 1987.** Prescribed burning of the sand pine community: Yamato scrub, a test case. *Florida Scientist*. 50: 184–192.
- Douglas, D.R. 1957.** Forest fire weather studies in South Australia. Bull. 9. Adelaide, SA: Woods and Forests Department of South Australia. 55 p.
- Douglas, D.R. 1964.** Some characteristics of major fires in coniferous plantations. *Australian Forestry*. 28: 119–124.
- Douglas, D.R. 1974.** Plantation fires. Adelaide, South Australia: Woods and Forests Department of South Australia. 43 p.
- Dupuy, J.L.; Morvan, D. 2005.** Numerical study of a crown fire spreading toward a fuel break using a multiphase physical model. *International Journal of Wildland Fire*. 14: 141–151.
- Duveneck, M.J. 2005.** Characterizing canopy fuels as they affect fire behavior in pitch pine (*Pinus rigida* P. Mill). Amherst, MA: University of Massachusetts. 93 p. M.S. thesis.
- Dyrness, C.T.; Norum, R.A. 1983.** The effects of experimental fires on black spruce forest floors in interior Alaska. *Canadian Journal of Forest Research*. 13: 879–893.
- Erdody, T.L.; Moskal, L.M. 2010.** Fusion of LIDAR and imagery for estimating forest canopy fuels. *Remote Sensing of Environment*. 114: 725–737.
- Fahnestock, G.R. 1970.** Two keys for appraising forest fire fuels. Res. Pap. PNW-99. Portland, OR: U.S. Department of Agriculture, Forest Service, Pacific Northwest Forest and Range Experiment Station. 26 p.
- Fernandes, P.M.; Loureiro, C.; Botelho, H.S. 2004.** Fire behaviour and severity in a maritime pine stand under differing fuel conditions. *Annals of Forest Science*. 61: 537–544.
- Finney, M.A. 2004.** FARSITE: Fire area simulator—model development and evaluation. Res. Pap. RMRS-RP-4 Revised. Fort Collins, CO: U.S. Department of Agriculture, Forest Service, Rocky Mountain Research Station. 47 p.
- Finney, M.A. 2006.** An overview of FlamMap fire modelling capabilities. In: Andrews, P.L.; Butler, B.W., comps. Fuels management—how to measure success: conference proceedings. Proc. RMRS-P-41. Fort Collins, CO: U.S. Department of Agriculture, Forest Service, Rocky Mountain Research Station: 213–220.
- Finney, M.; Cohen, J.; McAllister, S.; Jolly, M. 2013.** On the need for a theory of wildland fire spread. *International Journal of Wildland Fire*. 22: 25–36.
- Fogarty, L.G. 1996.** Two rural/urban interface fires in the Wellington suburb of Karori: assessment of burning conditions and fire control strategies. FRI Bull. No. 197, For. Rural Fire Sci. Tech. Ser. Rep. No. 1. Rotorua and Wellington, New Zealand: New Zealand Forest Research Institute and National Rural Fire Authority. 16 p.
- Folweiler, A.D. 1937.** Theory and practice of forest fire protection in the United States. St. Louis, MO: John S. Swift Co., Inc. 163 p.
- Fons, W.L.; Clements, H.B.; George, P.M. 1963.** Scale effects on propagation rate of laboratory crib fires. Symposium (International) on Combustion. 9: 860–866.

- Forestry Canada Fire Danger Group. 1992.** Development and structure of the Canadian Forest Fire Behavior Prediction System. Inf. Rep. ST-X-3. Ottawa, ON: Forestry Canada, Science and Sustainable Development Directorate. 63 p.
- Frandsen, W.H. 1991.** Burning rate of smoldering peat. *Northwest Science*. 65: 166–172.
- Fryer, G.I.; Johnson, E.A. 1988.** Reconstruction of fire behaviour and effects in a subalpine forest. *Journal of Applied Ecology*. 25: 1063–1072.
- Gisborne, H.T. 1927.** Meteorological factors in the Quartz Creek forest fire. *Monthly Weather Review*. 55: 56–60.
- Gisborne, H.T. 1929.** A forest fire explosion. *The Frontier Magazine*. 10(1): 13–16.
- Gisborne, H.T. 1935.** Shaded fire breaks. *Journal of Forestry*. 33: 86–87.
- Gisborne, H.T. 1948.** Fundamentals of fire behavior. *Fire Control Notes*. 9(1): 13–24. [republished in: *Fire Management Today*. 64(1): 15–23. 2004].
- Goens, D.W. 1990.** Meteorological factors contributing to the Canyon Creek blowup, September 6 and 7, 1988. In: *Proceedings of fifth conference on mountain meteorology*. Boston, MA: American Meteorological Society: 180–186. [also published as: 1990. NOAA Tech. Memorandum NWS WR-208. Salt Lake City, UT: U.S. Department of Commerce, National Weather Service, Western Region. 30 p.].
- Goens, D.W.; Andrews, P.L. 1998.** Weather and fire behavior factors related to the Dude Fire, AZ. In: *Preprint volume of second symposium on fire and forest meteorology*. Boston, MA: American Meteorological Society: 153–158.
- Goens, D.W.; Krumm, W.R. 2000.** Another look at the weather factors related to the 1949 Mann Gulch Fire. In: *Preprints of third AMS symposium on fire and forest meteorology*. Boston, MA: American Meteorological Society: 1–2.
- Gould, J.S.; McCaw, W.L.; Cheney, N.P.; Ellis, P.F.; Knight, I.K.; Sullivan, A.L. 2007.** Project Vesta. fire in dry eucalypt forest: fuel structure, fuel dynamics and fire behaviour. Canberra, Australian Capital Territory and Perth, Western Australia: Ensis-CSIRO and Department of Environment and Conservation. 218 p.
- Graham, R.T., tech. ed. 2003a.** Hayman Fire case study. Gen. Tech. Rep. RMRS-GTR-114. Ogden, UT: U.S. Department of Agriculture, Forest Service, Rocky Mountain Research Station. 396 p.
- Graham, R.T., tech. ed. 2003b.** Hayman Fire case study. Gen. Tech. Rep. RMRS-GTR-115. Ogden, UT: U.S. Department of Agriculture, Forest Service, Rocky Mountain Research Station. 32 p.
- Graham, R.; Finney, M.; McHugh, C.; Cohen, J.; Calkin, D.; Stratton, R.; Bradshaw, L.; Nikolov, N. 2012.** Fourmile Canyon Fire findings. Gen. Tech. Rep. RMRS-GTR-289. Fort Collins, CO: U.S. Department of Agriculture, Forest Service, Rocky Mountain Research Station. 108 p.
- Graham, R.T.; Harvey, A.E.; Jain, T.B.; Tonn, J.R. 1999.** The effects of thinning and similar stand treatments on fire behavior in Western forests. Gen. Tech. Rep. PNW-GTR-463. Portland, OR: U.S. Department of Agriculture, Forest Service, Pacific Northwest Research Station. 27 p.
- Graham, R.T.; McCaffrey, S.; Jain, T.B., tech. eds. 2004.** Science basis for changing forest structure to modify wildfire behavior and severity. Gen. Tech. Rep. RMRS-GTR-120. Ogden, UT: U.S. Department of Agriculture, Forest Service, Rocky Mountain Research Station. 43 p.
- Green, L.R. 1977.** Fuelbreaks and other fuel modification for wildland fire control. *Agric. Handb.* 499. Washington, DC: U.S. Department of Agriculture, Forest Service. 79 p.
- Grishin, A.M. 1997.** Mathematical modeling of forest fires and new methods of fighting them. Czuma, M.; Chikina, L.; Smokotina, L., translators. Albin, F.A. ed. Tomsk, Russia: Tomsk State University. 390 p.

- Haftl, L. 1998.** The devil in winter. *Wildland Firefighter*. 1(10): 27–29.
- Haines, D.A. 1988.** Downbursts and wildland fires: a dangerous combination. *Fire Management Notes*. 49(3): 8–10. [republished as: *Fire Management Today*. 64(1): 59–61. 2004].
- Haines, D.A. 1989.** Air tanker vortex turbulence—revisited. *Fire Management Notes*. 50(2): 14–15. [republished as: *Fire Management Today*. 64(1): 64–65. 2004].
- Haines, D.A.; Smith, M.C. 1987.** Three types of horizontal vortices observed in wildland mass and crown fires. *Journal of Climate and Applied Meteorology*. 26: 1624–1637.
- Hardy, C.E.; Franks, J.W. 1963.** Forest fires in Alaska. Res. Pap. INT-5. Ogden, UT: U.S. Department of Agriculture, Forest Service, Intermountain Forest and Range Experiment Station. 163 p.
- Harper, V.L. 1944.** Effects of fire on gum yields of longleaf and slash pines. Circular No. 710. Washington, DC: U.S. Department of Agriculture. 42 p.
- Hartford, R.A.; Rothermel, R.C. 1991.** Fuel moisture as measured and predicted during the 1988 fires in Yellowstone National Park. Res. Note INT-396. Ogden, UT: U.S. Department of Agriculture, Forest Service, Intermountain Research Station. 7 p.
- Hawley, R.C.; Stickel, P.W. 1948.** Forest protection. 2nd ed. New York: John Wiley and Sons. 355 p.
- Hester, D.A. 1952.** The pinyon-juniper fuel type can really burn. *Fire Control Notes*. 13(1): 26–29. [republished as: *Fire Management Today*. 63(3): 52–53. 2003].
- Hesterberg, G.A. 1959.** Controlling fires in Lake States timber types with sodium-calcium borate. Tech. Bull. No. 4. L'Anse, MI: Michigan College of Mining and Technology, Ford Forestry Center. 21 p.
- Hirsch, K.G. 1996.** Canadian Forest Fire Behavior Prediction (FBP) System: user's guide. Spec. Publ. 7. Edmonton, AB: Natural Resources Canada, Canadian Forest Service, Northern Forestry Centre. 121 p.
- Hirsch, K.G.; Flannigan, M.D. 1990.** Meteorological and fire behavior characteristics of the 1989 fire season in Manitoba, Canada. In: Proceedings of the international conference on forest fire research. Portugal, Coimbra: B:06: 1–16.
- Hirsch, K.G.; Martell, D.L.; Corey, P.N. 2000.** Probability of containment by medium initial attack crews in the boreal spruce fuel type. [Poster with text.] Edmonton, AB: Natural Resources Canada, Canadian Forest Service, Northern Forestry Centre. <http://cfs.nrcan.gc.ca/pubwarehouse/pdfs/18239.pdf>. (15 March 2013).
- Hirsch, S.N.; Meyer, G.F.; Radloff, D.L. 1979.** Choosing an activity fuel treatment for Southwest ponderosa pine. Gen. Tech. Rep. RM-67. Fort Collins, CO: U.S. Department of Agriculture, Forest Service, Rocky Mountain Forest and Range Experiment Station. 15 p.
- Hoffman, C.; Morgan, P.; Mell, W.; Parsons, R.; Strand, E.K.; Cook, S. 2012.** Simulation of crown fire hazard immediately after bark beetle-caused mortality in lodgepole pine forests. *Forest Science*. 58: 178–188.
- Hoffman, C.M.; Morgan, P.; Mell, W.; Parsons, R.; Strand, E.; Cook, S. 2013.** Surface fire intensity influences simulated crown fire behavior in lodgepole pine forests with recent mountain pine beetle-caused tree mortality. *Forest Science*. 59: 390–399.
- Honig, K.A.; Fulé, P.Z. 2012.** Simulating effects of climate change and ecological restoration on fire behaviour in a south-western USA ponderosa pine forest. *International Journal of Wildland Fire*. 21: 731–742.
- Hough, W.A. 1973.** Fuel and weather influence wildfires in sand pine forests. Res. Pap. SE-174. Asheville, NC: U.S. Department of Agriculture, Forest Service, Southeastern Forest Experiment Station. 11 p.
- Hough, W.A.; Albini, F.A. 1978.** Predicting fire behavior in palmetto-gallberry fuel complexes. Res. Pap. SE-174. Asheville, NC: U.S. Department of Agriculture, Forest Service, Southeastern Forest Experiment Station. 44 p.

- Jemison, G.M. 1932.** Meteorological observations affecting the Freeman Lake (Idaho) Fire. *Monthly Weather Review*. 60: 1–2.
- Jenkins, M.J.; Page, W.G.; Hebertson, E.G.; Alexander, M.E. 2012.** Fuels and fire behavior dynamics in bark-beetle attacked forests in western North America and implications for fire management. *Forest Ecology and Management*. 275: 23–34.
- Johansen, R.W.; Cooper, R.W. 1965.** Aerial attacks on sand pine crown fires. *Southern Lumberman*. 211(2732): 105–106.
- Johnson, E.A.; Gutsell, S.L. 1993.** Heat budget and fire behaviour associated with the opening of serotinous cones in two *Pinus* species. *Journal of Vegetation Science*. 4: 745–750.
- Johnson, E.A.; Miyanishi, K. 1995.** The need for consideration of fire behavior and effects in prescribed burning. *Restoration Ecology*. 3: 271–278.
- Johnson, M.C.; Kennedy, M.C.; Peterson, D.L. 2011.** Simulating fuel treatment effects in dry forests of western United States: testing the principles of a fire-safe forest. *Canadian Journal of Forest Research*. 41: 1018–1030.
- Johnson, M.C.; Peterson, D.L. 2005.** Forest fuel treatments in western North America: merging silvicultural and fire management. *Forestry Chronicle*. 81: 365–368.
- Johnson, V.J. 1964.** The chronology and analysis of the Hughes Fire, 1962. Res. Note NOR-8. Juneau, AK: U.S. Department of Agriculture, Forest Service, Northern Forest Experiment Station. 12 p.
- Johnson, V.J. 1966.** Seasonal fluctuation in moisture content of pine foliage. Res. Note NC-11. St. Paul, MN: U.S. Department of Agriculture, Forest Service, North Central Forest Experiment Station. 4 p.
- Jolly, W.M.; Parsons, R.A.; Hadlow, A.M.; Cohn, G.M.; McAllister, S.S.; Popp, J.B.; Hubbard, R.M.; Negron, J.F. 2012.** Relationships between moisture, chemistry and ignition of *Pinus contorta* needles during the early stages of mountain pine beetle attack. *Forest Ecology and Management*. 269: 52–59.
- Kasischke, E.S.; Rupp, T.S.; Verbyla, D.L. 2006.** Fire trends in the Alaskan boreal forest. In: Chapin, F.S., III; Oswood, M.W.; Van Cleve, K.; Viereck, L.A., eds. *Alaska's changing boreal forest*. New York: Oxford University Press: 285–301.
- Keane, R.E. 2014.** *Wildland fuel fundamentals and application*. New York: Springer. 191 p.
- Keeves, A.; Douglas, D.R. 1983.** Forest fires in South Australia on 16 February 1983 and consequent future forest management aims. *Australian Forestry*. 46: 148–162.
- Keller, P., ed. 2011.** How fuel treatments saved homes from the 2011 Wallow Fire. Tuscon, AZ: U.S. Department of Agriculture Forest Service, Wildland Fire Lessons Learned Center. 14 p. http://www.fs.usda.gov/Internet/FSE_DOCUMENTS/stelprdb5358240.pdf. (1 June 2012).
- Kendrick, B.; Walsh, B. 2007.** *A history of Florida forests*. Gainesville, FL: University Press of Florida. 585 p.
- Kerr, W.L.; Buck, C.C.; Cline, W.E.; Martin, S.; Nelson, W.D. 1971.** Nuclear weapons effects in a forest environment—thermal and fire. Rep. N2: TR 2-70. Santa Barbara, CA: General Electric Company-TEMPO and Department of Defence Nuclear Information Analysis Center. [Not paged].
- Kessell, S.R.; Good, R.B.; Potter, M.W. 1980.** Computer modelling in natural area management. Spec. Publ. 9. Canberra, Australian Capital Territory: Commonwealth of Australia, Australian National Parks and Wildlife Service. 45 p.
- Keyes, C.R. 1996.** Stand structure and silvicultural strategies to prevent crown fires in Northern Rocky Mountain forests. Missoula, MT: University of Montana. 116 p. M.S. thesis.

- Keyes, C.R. 2006.** Role of foliar moisture content in the silvicultural management of forest fuels. *Western Journal of Applied Forestry*. 21: 228–231.
- Keyes, C.R.; O'Hara, K.L. 2002.** Quantifying stand targets for silvicultural prevention of crown fires. *Western Journal of Applied Forestry*. 17: 101–109.
- Keyes, C.R.; Varner, J.M. 2006.** Pitfalls in the silvicultural treatment of canopy fuels. *Fire Management Today*. 66(3): 46–50.
- Kiil, A.D. 1975.** Fire spread in a black spruce stand. *Canadian Forestry Service Bi-monthly Research Notes*. 31: 2–3.
- Kiil, A.D. 1976.** Fire behavior and the use of fire retardants in Canadian forests. In: Bhatnagar, V.M., ed. *Fire retardants: proceedings of 1975 international symposium on flammability and fire retardants*. Westport, CT: Technomic Publishing Company Incorporated: 175–186.
- Kiil, A.D.; Grigel, J.E. 1969.** The May 1968 forest conflagrations in central Alberta—a review of fire weather, fuels and fire behavior. Inf. Rep. A-X-24. Edmonton, AB: Canada Department of Fisheries and Forestry, Forestry Branch, Forest Research Laboratory. 36 p.
- Kiil, A.D.; Miyagawa, R.S.; Quintilio, D. 1977.** Calibration and performance of the Canadian Fire Weather Index in Alberta. Inf. Rep. NOR-X-173. Edmonton, AB: Environment Canada, Canadian Forestry Service, Northern Forest Research Centre. 45 p.
- Kilgore, B.M.; Sando, R.W. 1975.** Crown-fire potential in a sequoia forest after prescribed burning. *Forest Science*. 21: 83–87.
- Klutsch, J.G.; Battaglia, M.A.; West, D.R.; Costello, S.L.; Negrón, J.F. 2011.** Evaluating potential fire behavior in lodgepole pine-dominated forests after a mountain pine beetle epidemic in north-central Colorado. *Western Journal of Applied Forestry* 26: 101–109.
- Koch, E. 1942.** History of the 1910 forest fires in Idaho and western Montana. Missoula, MT: U.S. Department of Agriculture, Forest Service, Region 1. 25 p. [reproduced in: *When the Mountains Roared: Stories of the 1910 Fire*. Publ. R1-78-30. U.S. Department of Agriculture, Forest Service, Idaho Panhandle National Forests. 1978.]
- Kramer, H.A.; Collins, B.M.; Kelly, M.; Stephens, S.L. 2014.** Quantifying ladder fuels: a new approach using LiDAR. *Forests*. 5: 1432–1453
- Krumm, W.R. 1959.** Fire weather. In: Davis, K.P., ed. *Forest fire: control and use*. New York: McGraw-Hill: 124–160, 556–557.
- Kuljian, H.G. 2010.** Assessing the impact of sudden oak death on crown fire potential in tanoak forests of California. Arcata, CA: Humboldt State University. 72 p. M.S. thesis.
- Kuljian, H.; Varner, J.M. 2010.** The effects of sudden death oak on foliar moisture content and crown fire potential in tanoak. *Forest Ecology and Management*. 259: 2103–2110.
- Kylie, H.R.; Hieronymus, G.H.; Hall, A.G. 1937.** CCC forestry. Washington, DC: U.S. Government Printing Office. 335 p.
- LaMois, L. 1958.** Fire fuels in red pine plantations. Stn. Pap. 68. St. Paul, MN: U.S. Department of Agriculture, Forest Service, Lake States Forest Experiment Station. 19 p.
- Lavoie, N.; Alexander, M.E.; Macdonald, E.S. 2010.** Photo guide for quantitatively assessing characteristics of forest fuels in a jack pine—black spruce chronosequence in the Northwest Territories. Inf. Rep. NOR-X-419. Edmonton, AB: Natural Resources Canada, Canadian Forest Service, Northern Forestry Centre. 42 p.
- Lawson, B.D. 1972.** Fire spread in lodgepole pine stands. Missoula, MT: University of Montana. 119 p. M.S. thesis.
- Lawson, B.D. 1973.** Fire behavior in lodgepole pine stands related to the Canadian Fire Weather Index. Inf. Rep. BC-X-176. Victoria, BC: Environment Canada, Canadian Forestry Service, Pacific Forest Research Centre. 26 p.

- Lawson, B.D.; Armitage, O.B. 2008.** Weather guide for the Canadian Forest Fire Danger Rating System. Edmonton, AB: Natural Resources Canada, Canadian Forest Service, Northern Forestry Centre. 73 p.
- Lawson, B.D.; Armitage, O.B.; Dalrymple, G.N. 1994.** Ignition potentials for simulated people-caused fires in British Columbia's lodgepole pine and white spruce-subalpine fir forests. In: Proceedings of the 12th conference on fire and forest meteorology. SAF Publ. 94-02. Bethesda, MD: Society of American Foresters: 493–505.
- Lawson, B.D.; Dalrymple, G.N. 1996.** Probabilities of sustained ignition in lodgepole pine, interior, Douglas-fir, and white spruce-subalpine fir forest types. Suppl. 1 to FRDA Handb. 12. Victoria, BC: Canadian Forest Service, Pacific Forestry Centre and British Columbia Ministry of Forests, Research Branch. 17 p.
- Lawson, B.D.; Stocks, B.J.; Alexander, M.E.; Van Wagner, C.E. 1985.** A system for predicting fire behavior in Canadian Forests. In: Donoghue, L.R.; Martin, R.E., eds. Proceedings of eighth conference on fire and forest meteorology. SAF Publ. 85-04. Bethesda, MD: Society of American Foresters: 6–16.
- Leonard, D.; Swap, W. 2005.** Deep smarts: how to cultivate and transfer enduring business wisdom. Boston, MA: Harvard Business School Publishing. 288 p.
- Lindenmuth, A.W., Jr.; Davis, J.R. 1973.** Predicting fire spread in Arizona's oak chaparral. Res. Pap. RM-101. Fort Collins, CO: U.S. Department of Agriculture, Forest Service, Rocky Mountain Forest and Range Experiment Station. 11 p.
- Linn, R.; Anderson, K.; Winterkamp, J.; Brooks, A.; Wotton, M.; Dupuy, J.-L.; Pimont, F.; Edminster, C. 2012.** Incorporating field wind data into FIRETEC simulations of the International Crown Fire Modeling Experiment (ICFME): preliminary lessons learned. Canadian Journal of Forest Research. 42: 879–898.
- Linn, R.; Reisner, J.; Colman, J.J.; Winterkamp, J. 2002.** Studying wildfire behavior using FIRETEC. International Journal of Wildland Fire. 11: 233–246.
- Linn, R.; Sieg, C.H.; Hoffman, C.D.; Winterkamp, J.L.; McMillin, J.D. 2013.** Modeling wind fields and fire propagation following bark beetle outbreaks in spatially-heterogeneous pinyon-juniper woodland fuel complexes. Agricultural and Forest Meteorology. 173: 139–153.
- Linn, R.; Winterkamp, J.; Colman J.J.; Edminster, C.; Bailey, J.D. 2005.** Modeling interactions between fire and atmosphere in discrete element fuel beds. International Journal of Wildland Fire. 14: 37–48.
- Luke, R.H. 1961.** Bush fire control in Australia. Melbourne, VIC: Hodder and Stoughton Ltd. 136 p.
- Luke, R.H. 1962.** Meeting protection objectives in difficult years. In: Proceedings of the fifth world forestry congress, Volume 2. Washington, DC: U.S. Department of Agriculture, Forest Service: 971–978.
- Luke, R.H.; McArthur, A.G. 1978.** Bushfires in Australia. Canberra, Australian Capital Territory: Australian Government Publishing Service. 359 p.
- Macleay, N. 1992.** Young men and fire. Chicago, IL: University of Chicago Press. 301 p.
- Malchanov, V.P. 1957.** Conditions for the spread of crown fires in pine forests. Lesnoe Khoziaistvo. 10(8): 50–53. [In Russian] (Available in English as: Canada Department of Forestry and Rural Development Translation ODF TR213. 1968).
- McAlpine, R.S.; Hobbs, M.W. 1994.** Predicting the height to live crown base in plantations of four boreal forest species. International Journal of Wildland Fire. 4: 103–106.
- McAlpine, R.S.; Lawson, B.D.; Taylor, E. 1991.** Fire spread across a slope. In: Andrews, P.L.; Potts, D.F., eds. Proceedings of the 11th conference on fire and forest meteorology. SAF Publ. 91-04. Bethesda, MD: Society of American Foresters: 218–225.

- McAlpine, R.S.; Wakimoto, R.H. 1991.** The acceleration of fire spread from point source to equilibrium spread. *Forest Science*. 37: 1314–1337
- McAlpine, R.S.; Wotton, B.M. 2009.** Fire behaviour knowledge base (fbkb.ca). In: Proceedings of eighth symposium on fire and forest meteorology, Boston, MA: American Meteorological Society. 4 p. http://ams.confex.com/ams/8Fire/techprogram/paper_156228.htm. (18 June 2011).
- McArthur, A.G. 1962.** Control burning in eucalypt forests. Leaflet No. 80. Canberra, Australian Capital Territory: Commonwealth of Australia, Forestry and Timber Bureau, Forest Research Institute. 31 p.
- McArthur, A.G. 1965.** Fire behaviour characteristics of the Longford Fire. Leaflet No. 91. Canberra, Australian Capital Territory: Commonwealth of Australia, Forestry and Timber Bureau, Forest Research Institute. 19 p.
- McArthur, A.G. 1966.** Weather and grassland fire behaviour. Leaflet No. 100. Canberra, Australian Capital Territory: Commonwealth of Australia, Forestry and Timber Bureau, Forest Research Institute. 23 p.
- McArthur, A.G. 1967.** Fire behaviour in eucalypt forests. Leaflet No. 107. Canberra, Australian Capital Territory: Commonwealth of Australia, Forestry and Timber Bureau, Forest Research Institute. 36 p.
- McArthur, A.G. 1973.** Forest Fire Danger Meter. Mk. 5. Canberra, Australian Capital Territory: Commonwealth of Australia, Forestry and Timber Bureau, Forest Research Institute. Circular slide-rule with text.
- McArthur, A.G.; Cheney, N.P. 1966.** The characterization of fires in relation to ecological studies. *Australian Forest Research*. 2(3): 36–45.
- McArthur, A.G.; Douglas, D.R.; Mitchell, L.R. 1966.** The Wandilo Fire, 5 April 1958—fire behaviour and associated meteorological and fuel conditions. Leaflet No. 98. Canberra, Australian Capital Territory: Commonwealth of Australia, Forestry and Timber Bureau, Forest Research Institute. 30 p. + Appendices.
- McCaw, W.L. 1997.** Predicting fire spread in Western Australia mallee-heath shrubland. Canberra, Australian Capital Territory: University of New South Wales, University College, Department of Mathematics. 240 p. Ph.D. thesis.
- McCaw, W.L.; Alexander, M.E. 1994.** Tripartite agreement on wildland fire science research signed. *International Forest Fire News*. 11: 27–29.
- McCaw, W.L.; Smith, R.; Neal, J. 1988.** Intense fire behaviour in a 16-year-old stand of karri (*Eucalyptus diversicolor*) and yellow stringybark (*Eucalyptus mullerana*). Landnote 3/88. Perth, WA: Department of Conservation and Land Management. 8 p.
- McHugh, C.W. 2006.** Considerations in the use of models available for fuel treatment analysis. In: Andrews, P.L.; Butler, B.W., eds. Fuels management—how to measure success: conference proceedings. Proc. RMRS-P-41. Fort Collins, CO: U.S. Department of Agriculture, Forest Service, Rocky Mountain Research Station: 81–105.
- McRae, D.J.; Ji-zhong, J. 2004.** An infrared approach to forest fire behavior quantification. In: Engstrom, R.T.; Galley, K.E.M.; de Groot, W.J., eds. Proceedings of the 22nd tall timbers fire ecology conference: fire in temperate, boreal, and montane ecosystems. Tallahassee, FL: Tall Timbers Research Station: 154–162.
- Mell, W.; Jenkins, M.A.; Gould, J.; Cheney, P. 2007.** A physics-based approach to modelling grassland fires. *International Journal of Wildland Fire*. 16: 1–22.
- Menning, K.M.; Stephens, S.L. 2007.** Fire climbing in the forest: a semiquantitative, semiquantitative approach to assessing ladder fuel hazards. *Western Journal of Applied Forestry*. 22: 88–93.
- Merrill, D.F.; Alexander, M.E., eds. 1987.** Glossary of forest fire management terms. 4th ed. Publication NRCC No. 26516. Ottawa, ON: National Research Council of Canada, Canadian Committee of Forest Fire Management. 90 p.

- Miller, E.A.; Renkin, R.A.; McEldery, S.C.; Klukas, T.J. 2009.** A case study of crown fire in an early post-fire lodgepole pine forest [extended abstract]. In: Masters, R.E.; Galley, K.E.M.; Despain, D.G., eds. The '88 fires: Yellowstone and beyond. Tall Timbers Misc. Publ. No. 16. Tallahassee, FL: Tall Timbers Research Station: 26.
- Morvan, D. 2011.** Physical phenomena and length scales governing the behaviour of wildfires: a case for physical modelling. *Fire Technology*. 47: 437–460.
- Mottus, B.; Pengelly, I. 2004.** An analysis of the meteorological conditions associated with the 1999 Panther River Fire in Banff National Park [Abstract]. In: Engstrom, R.T.; Galley, K.E.M.; de Groot, W.J.; eds. Proceedings of the 22nd tall timbers fire ecology conference: fire in temperate, boreal, and montane ecosystems. Tallahassee, FL: Tall Timbers Research Station: 239.
- Muraro, S.J. 1971.** The lodgepole pine fuel complex. Inf. Rep. BC-X-53. Victoria, BC: Environment Canada, Canadian Forestry Service, Pacific Forest Research Centre. 50 p.
- Murphy, K.; Rich, T.; Sexton, T. 2007.** An assessment of fuel treatment effects on fire behavior, suppression effectiveness, and structure ignition on the Angora Fire. Tech. Publ. R5-TP-025. Vallejo, CA: U.S. Department of Agriculture, Forest Service, Pacific Southwest Region. 32 p.
- Mutch, R.W. 1998.** Long-range fire behavior assessments: your fire behavior future. In: Close, K.; Bartlette, R.A., eds. Fire management under fire (adapting to change): proceedings of the 1994 Interior West Fire Council meeting and program. Fairfield, WA: International Association of Wildland Fire: 69–73.
- Mutch, R.W.; Rothermel, R.C. 1986.** 73 fire fighters survive in shelters. *Fire Command*. 53(3): 30–32, 48.
- National Fire Protection Association. 1990.** Black Tiger Fire case study. Quincy, MA: National Fire Protection Association. 40 p.
- National Fire Protection Association. 1991.** Stephan Bridge Road Fire case study. Quincy, MA: National Fire Protection Association. 40 p.
- National Fire Protection Association. 1992.** Firestom '91 case study. National Fire Protection Association. 31 p.
- National Wildfire Coordinating Group. 1992.** Fire behavior field reference guide. Publication NFES 2224. Boise, ID: National Fire Equipment System, Boise Interagency Fire Center. [Not paged].
- National Wildfire Coordinating Group. 1993.** Look up, look down, look around [VHS videotape; 50 minutes]. Publication NFES 2244. Boise, ID: National Fire Equipment System, Boise Interagency Fire Center. <http://www.youtube.com/watch?v=EUP4lrK1dUw>.
- Nelson, R.M., Jr. 1980.** Flame characteristics for fires in southern fuels. Res. Pap. SE-205. Asheville, NC: U.S. Department of Agriculture, Forest Service, Southeastern Forest Experiment Station. 14 p.
- Nelson, R.M., Jr. 1993a.** Byram's energy criterion for wildland fires: units and equations. Res. Note INT-415. Ogden, UT: U.S. Department of Agriculture, Forest Service, Intermountain Research Station. 5 p.
- Nelson, R.M., Jr. 1993b.** Byram's derivation of the energy criterion for forest and wildland fires. *International Journal of Wildland Fire*. 3: 131–138.
- Nelson, R.M., Jr. 2003a.** Power of the fire—a thermodynamic analysis. *International Journal of Wildland Fire*. 12: 51–63.
- Nelson, R.M., Jr. 2003b.** Reaction times and burning rates for wind tunnel headfires. *International Journal of Wildland Fire*. 12: 195–211.
- Nelson, R.M., Jr.; Adkins, C.W. 1988.** A dimensionless correlation for the spread of wind-driven fires. *Canadian Journal of Forest Research*. 18: 391–397.
- Newcomb, L.S. 1957.** The Osceola Fire and the timber salvage operation. *Southern Lumberman*. 193(2417): 39–41.

- Noonan-Wright, E.K.; Opperman, T.S.; Finney, M.A.; Zimmerman, G.T.; Seli, R.C.; Elenz, L.M.; Calkin, D.E.; Fiedler, J.R. 2011.** Developing the US Wildland Fire Decision Support System. *Journal of Combustion*. 2011: Article ID 168473. 14 p.
- Norum, R.A. 1975.** Characteristics and effects of understory fires in western larch/Douglas-fir stands. Missoula, MT: University of Montana. 155 p. Ph.D. dissertation.
- Norum, R.A. 1982.** Predicting wildfire behavior in black spruce forests in Alaska. Res. Note PNW-401. Portland, OR: U.S. Department of Agriculture, Forest Service, Pacific Northwest Forest and Range Experiment Station. 10 p.
- Norum, R.A.; Miller, M. 1984.** Measuring fuel moisture content in Alaska: standard methods and procedures. Gen. Tech. Rep. PNW-171. Portland, OR: U.S. Department of Agriculture, Forest Service, Pacific Northwest Forest and Range Experiment Station. 34 p.
- O'Connor, P.; O'Connor, B. 1993.** Out of the ashes: the Ash Wednesday bushfires in the south east of S.A., 16th February 1983. Millicent, South Australia: Millicent Press. 176 p.
- Omi, P.N. 2005.** Forest fires: a reference handbook. Santa Barbara, CA: ABC-CLIO, Inc. 347 p.
- Ottmar, R.D.; Sandberg, D.V.; Riccardi, C.L.; Prichard, S.J. 2007.** An overview of the fuel characteristic classification system—quantifying, classifying, and creating fuelbeds for resource planning. *Canadian Journal of Forest Research*. 37: 2383–2393.
- Page, W.G.; Jenkins, M.J.; Runyon, J.B. 2012.** Mountain pine beetle attack alters the chemistry and flammability of lodgepole pine foliage. *Canadian Journal of Forest Research*. 42: 1631–1647.
- Page, W.G.; Alexander, M.E.; Jenkins, M.J. 2013a.** Wildfire's resistance to control in mountain pine beetle-attacked lodgepole pine forests. *Forestry Chronicle*. 89: 783–794.
- Page, W.G.; Jenkins, M.J.; Alexander, M.E. 2013b.** Foliar moisture content variations in lodgepole pine over the diurnal cycle during the red stage of mountain pine beetle attack. *Environmental Modelling and Software*. 49: 98–102.
- Page, W.G.; Jenkins, M.J. Alexander, M.E. 2014.** Crown fire potential in lodgepole pine forests during the red stage of mountain pine beetle attack. *Forestry*. 87: 347–361.
- Parresol, B.R. 2007.** Estimating canopy fuel parameters for Atlantic Coastal Plain forest types. DE-AI09-00SR22188 Tech. Rep. 07-16-R. Asheville, NC: U.S. Department of Agriculture, Forest Service, Southern Research Station. 35 p.
- Parresol, B.R.; Scott, J.H.; Andreu, A.; Prichard, S.; Kurth, L. 2012.** Developing custom fire behavior fuel models from ecologically complex fuel structures for upper Atlantic Coast Plain forests. *Forest Ecology and Management*. 273: 50–57.
- Parsons, R.A.; Mell, W.E.; McCauley, P. 2011.** Linking 3D spatial models of fuels and fire: effects of spatial heterogeneity on fire behavior. *Ecological Modeling*. 222: 679–691.
- Parsons, R.A.; Sauer, J.; Linn, R.R. 2010.** Crown fuel spatial variability and predictability of fire spread. In: Viegas, D.X., ed. Proceedings of the 6th international conference on forest fire research. [CD-ROM]. Coimbra, Portugal: University of Coimbra. 14 p.
- Pastor, E.; Zárate, L.; Planas, E.; Arnaldos, J. 2003.** Mathematical models and calculation systems for the study of wildland fire behavior. *Progress in Energy and Combustion Science*. 29: 139–153.
- Paxton, J. 2007.** The monster reared his ugly head—the story of Rodeo-Chediski Fire and fire as a tool of nature. Snowflake, AZ: Cedar Hill Publishing. 217 p.

- Pearce, H.G.; Alexander, M.E. 1994.** Fire danger ratings associated with New Zealand's major pine plantation wildfires. In: Proceedings of 12th conference on fire and forest meteorology. SAF Publ. 94-02. Bethesda, MD: Society of American Foresters: 534–543.
- Pence, M.; Zimmerman, T. 2011.** The Wildland Fire Decision Support System: integrating science, technology, and fire management. *Fire Management Today*. 71(1): 18–22.
- Peterson, D.L.; Johnson, M.C.; Agee, J.K.; Jain, T.B.; McKenzie, D.; Reinhardt, E.D. 2005.** Forest structure and fire hazard in dry forests of the Western United States. Gen. Tech. Rep. PNW-GTR-628. Portland, OR: U.S. Department of Agriculture, Forest Service, Pacific Northwest Research Station. 30 p.
- Philpot, C.W.; Mutch, R.W. 1971.** The seasonal trends in moisture content, ether extractives, and energy of ponderosa pine and Douglas-fir needles. Res. Pap. INT-102. Ogden, UT: U.S. Department of Agriculture, Forest Service, Intermountain Forest and Range Experiment Station. 21 p.
- Pickett, B.M.; Isackson, C.; Wunder, R.; Fletcher, T.H.; Butler, B.W.; Weise, D.R. 2010.** Experimental measurements during combustion of moist individual foliage samples. *International Journal of Wildland Fire*. 19: 153–162.
- Plucinski, M.P. 2003.** The investigation of factors governing ignition and development of fires in heathland vegetation. Canberra, Australian Capital Territory. University of New South Wales, Australian Defence Force Academy, School of Mathematics and Statistics. 347 p. Ph.D. thesis.
- Pollack, H.N. 2003.** Uncertain science ... uncertain world. Cambridge, United Kingdom: Cambridge University Press. 256 p.
- Pook, E.W.; Gill, A.M. 1993.** Variation of live and dead fine fuel moisture in *Pinus radiata* plantations of the Australian Capital Territory. *International Journal of Wildland Fire*. 3: 155–168.
- Porterie, B.; Loraud, J.C.; Bellemare, L.O.; Consalvi, J.L. 2003.** A physical based model of the onset of crowning. *Combustion Science and Technology*. 175: 1109–1141.
- Poulin, S.; Alexander, M.E.; Osesky, T.; Maczek, P., eds. 1994.** 1994 supplement to: Canadian Committee on Forest Fire Management 1987 Glossary of Forest Fire Management Terms. 4th ed. Winnipeg, MB: Canadian Committee on Forest Fire Management. 8 p.
- Pyne, S.J.; Andrews, P.L.; Laven, R.D. 1996.** Introduction to wildland fire. 2nd ed. New York: John Wiley & Sons, Inc. 769 p.
- Quintilio, D.; Fahnestock, G.R.; Dube, D.E. 1977.** Fire behavior in upland jack pine: the Darwin Lake project. Inf. Rep. NOR-X-174. Edmonton, AB: Fisheries and Environment Canada, Canadian Forestry Service, Northern Forest Research Centre. 49 p.
- Quintilio, D.; Lawson, B.D.; Walkinshaw, S.; Van Nest, T. 2001.** Final documentation report—Chisholm Fire (LWF-063). Publ. No. I/036. Edmonton, AB: Alberta Sustainable Resource Development, Forest Protection Division. [Not paged].
- Racher, B. 2003.** Prescription development for burning two volatile fuel types. Lubbock, TX: Texas Tech University. 72 p. Ph.D. dissertation.
- Radke, L.R.; Clark, T.L.; Coen, J.L.; Walther, C.; Lockwood, R.N.; Riggin, P.J.; Brass, J.; Higgins, R. 2000.** The Wildfire Experiment (WiFE): observations with airborne remote sensors. *Canadian Journal of Remote Sensing*. 26: 406–417.
- Reeves, M.C.; Ryan, K.C.; Rollins, M.G.; Thompson, T.G. 2009.** Spatial fuel data products of the LANDFIRE Project. *International Journal of Wildland Fire*. 18: 250–267.
- Reifsnyder, W.E. 1961.** Seasonal variation in the moisture content of green leaves of mountain laurel. *Forest Science*. 7: 16–23.

Reinhardt, E.D.; Crookston, N.L., tech eds. 2003.

The Fire and Fuels Extension to the Forest Vegetation Simulator. Gen. Tech. Rep. RMRS-GTR-116. Ogden, UT: U.S. Department of Agriculture, Forest Service, Rocky Mountain Research Station. 209 p.

Reinhardt, E.; Scott, J.; Gray, K.; Keane, R. 2006.

Estimating canopy fuel characteristics in five conifer stands in the western United States using tree and stand measurements. Canadian Journal of Forest Research. 36: 2803–2814.

Rossotti, H. 1993. Fire. New York: Oxford University Press. 288 p.

Rothermel, R.C. 1968. Sundance Fire. Fire Research Abstracts and Reviews. 10: 127–129.

Rothermel, R.C. 1972. A mathematical model for predicting fire spread in wildland fuels. Res. Pap. INT-115. Ogden, UT: U.S. Department of Agriculture, Forest Service, Intermountain Forest and Range Experiment Station. 40 p.

Rothermel, R.C. 1983. How to predict the spread and intensity of forest and range fires. Gen. Tech. Rep. INT-143. Ogden, UT: U.S. Department of Agriculture, Forest Service, Intermountain Forest and Range Experiment Station. 161 p.

Rothermel, R.C. 1985. Fire behavior considerations of aerial ignition In: Mutch, R.W., tech. coord. Prescribed fire by aerial ignition. Proceedings of a workshop. Missoula, MT: Intermountain Fire Council: 143–158.

Rothermel, R.C. 1987. Fire behavior research: where do we go from here? In: Conference papers of the ninth conference on fire and forest meteorology. Boston, MA: American Meteorological Society: 19–22.

Rothermel, R.C. 1991a. Crown fire analysis and interpretation. In: Andrews, P.L.; Potts, D.F., eds. Proceedings of the 11th conference on fire and forest meteorology. SAF Publ. 91-04. Bethesda, MD: Society of American Foresters: 253–263.

Rothermel, R.C. 1991b. Predicting behavior and size of crown fires in the northern Rocky Mountains. Res. Pap. INT-438. Ogden, UT: U.S. Department of Agriculture, Forest Service, Intermountain Research Station. 46 p.

Rothermel, R.C. 1991c. Predicting behavior of the 1988 Yellowstone fires: projections versus reality. International Journal of Wildland Fire. 1: 1–10.

Rothermel, R.C. 1993. Mann Gulch Fire: a race that couldn't be won. Gen. Tech. Rep. INT-299. Ogden, UT: U.S. Department of Agriculture, Forest Service, Intermountain Research Station. 10 p.

Rothermel, R.C. 1994. Some fire behavior modelling concepts for fire management systems. In: Proceedings of the 12th conference on fire and forest meteorology. SAF Publ. 94-02. Bethesda, MD: Society of American Foresters: 164–171.

Rothermel, R.C. 1995. Characterizing severe fire behavior. In: Brown, J.K.; Mutch, R.W.; Spoon, C.W.; Wakimoto, R.H., tech. cords. Proceedings: symposium on fire in wilderness and park management. Gen. Tech. Rep. INT-GTR-320. Ogden, UT: U.S. Department of Agriculture, Forest Service, Intermountain Research Station: 262–264.

Rothermel, R.C. 1998. Long-range fire assessments. In: Close, K.; Bartlette, R.A., eds. Fire management under fire (adapting to change): proceedings of the 1994 Interior West Fire Council meeting and program. Fairfield, WA: International Association of Wildland Fire: 169–179.

Rothermel, R.C. 2000. The great western wildland fires: predicting the future by looking at the past. National Woodlands. 23(4): 10–12.

Rothermel, R.C.; Anderson, H.E. 1966. Fire spread characteristics in the laboratory. Res. Pap. INT-30. Ogden, UT: U.S. Department of Agriculture, Forest Service, Intermountain Forest and Range Experiment Station. 34 p.

- Rothermel, R.C.; Andrews, P.L. 1987.** Fire behavior system for the full range of fire management needs. In: Davis, J.B.; Martin, R.E., tech. cords. Proceedings of the symposium on wildland fire 2000. Gen. Tech. Rep. PSW-101. Berkeley, CA: U.S. Department of Agriculture, Forest Service, Pacific Southwest Forest and Range Experiment Station: 145–151.
- Rothermel, R.C.; Gorski, C.J. 1987.** Cause of Butte Fire blowup. In: Proceedings, ninth conference on fire and forest meteorology. Boston, MA: American Meteorological Society: 191–196.
- Rothermel, R.C.; Hartford, R.A.; Chase, C.H. 1994.** Fire growth maps for the 1988 Greater Yellowstone Area fires. Gen. Tech. Rep. INT-304. Ogden, UT: U.S. Department of Agriculture, Forest Service, Intermountain Research Station. 64 p.
- Rothermel, R.C.; Mutch, R.W. 1986.** Behavior of the life-threatening Butte Fire: August 27-29, 1985. Fire Management Notes. 47(2): 14-24. [republished in 2003 as: Fire Management Today. 63(4): 31–39].
- Rothermel, R.C.; Reinhart, G.C. 1983.** Field procedures for verification and adjustment of fire behavior predictions. Gen. Tech. Rep. INT-142. Ogden, UT: U.S. Department of Agriculture, Forest Service, Intermountain Forest and Range Experiment Station. 25 p.
- Rothermel, R.C.; Wilson, R.A., Jr.; Morris, G.A.; Sackett, S.S. 1986.** Modeling moisture content of fire dead wildland fuels: input to the BEHAVE fire prediction system. Res. Pap. INT-359. Ogden, UT: U.S. Department of Agriculture, Forest Service, Intermountain Research Station. 61 p.
- Roussopoulos, P.J. 1978a.** A decision aid for wilderness fire prescriptions in the Boundary Waters Canoe Area. In: Preprint volume of 5th national conference on fire and forest meteorology. Boston, MA: American Meteorological Society: 52–58.
- Roussopoulos, P.J. 1978b.** An appraisal of upland forest fuels and potential fire behavior for a portion of the Boundary Waters Canoe Area. East Lansing, MI: Michigan State University. 166 p. Ph.D. dissertation.
- Sackett, S.S.; DeCoste, J.H. 1967.** A new mobile fire laboratory. Fire Control Notes. 28(4): 7–9.
- Sackett, S.S. 1975.** Scheduling prescribed burns for hazard reduction in the Southeast. Journal of Forestry. 73: 143–147.
- Sackett, S.S. 1979.** Natural fuel loadings in ponderosa pine and mixed conifer forests in the Southwest. Res. Pap. RM-213. Fort Collins, CO: U.S. Department of Agriculture, Forest Service, Rocky Mountain Forest and Range Experiment Station. 10 p.
- Sandberg, D.V.; Riccardi, C.L.; Schaaf, M.D. 2007.** Reformulation of Rothermel’s wildland fire behaviour model for heterogeneous fuelbeds. Canadian Journal of Forest Research. 37: 2438–2455.
- Sando, R.W.; Haines, D.A. 1972.** Fire weather and behavior of the Little Sioux Fire. Res. Pap. NC-76. St. Paul, MN: U.S. Department of Agriculture, Forest Service, North Central Forest Experiment Station. 6 p.
- Sando, R.W.; Wick, C.H. 1972.** A method of evaluating crown fuels in forest stands. Res. Pap. NC-84. St. Paul, MN: U.S. Department of Agriculture, Forest Service, North Central Forest Experiment Station. 10 p.
- Schaaf, M.D.; Sandberg, D.V.; Schreuder, M.D.; Riccardi, C.L. 2007.** A conceptual framework for ranking crown fire potential in wildland fuelbeds. Canadian Journal of Forest Research. 37: 2464–2478.
- Schaefer, V.J. 1961.** Better quantitative observations of atmospheric phenomena in going fires. In: Proceedings of the Society of American Foresters meeting. Washington, DC: Society of American Foresters: 120–124.
- Schoennagel, T.; Veblen, T.T.; Negron, J.F.; Smith, J.M. 2012.** Effects of mountain pine beetle on fuels and expected fire behavior in lodgepole pine forests, Colorado, USA. PLoS ONE. 7(1): e30002. 14 p.

- Schreuder, M.D.; Schaaf, M.D.; Sandberg, D.V. 2010.** Evaluation of the FCCS crown fire potential equations in Aleppo pine (*Pinus halepensis* Mill.) stands in Greece. In: Perona, G.; Brebbia, C.A., eds. Modelling, monitoring and management of forest fires II. Ecology and the Environment Volume 137. Southampton, United Kingdom: WIT Press: 259–270.
- Schroeder, M.J.; Buck, C.C. 1970.** Fire weather ... a guide for application of meteorological information to forest fire control operations. Agric. Handb. 360. Washington, DC: U.S. Department of Agriculture. 229 p.
- Scott, A.C.; Bowman, D.M.J.S.; Bond, W.J.; Pyne, S.J.; Alexander, M.E. 2014.** Fire on earth: an Introduction. Chichester, United Kingdom: Wiley-Blackwell. 413 p.
- Scott, J.H. 1998a.** Development of two indices of crown fire hazard and their application in a western Montana ponderosa pine stand. Missoula, MT: University of Montana. 75 p. M.S. thesis.
- Scott, J.H. 1998b.** Fuel reduction in residential and scenic forests: a comparison of three treatments in a western Montana ponderosa pine stand. Res. Pap. RMRS-RP-5. Ogden, UT: U.S. Department of Agriculture, Forest Service, Rocky Mountain Research Station. 19 p.
- Scott, J.H. 1998c.** Reduce fire hazards in ponderosa pine by thinning. Fire Management Notes. 58(1): 20–25.
- Scott, J.H. 1998d.** Sensitivity analysis of a method for assessing crown fire hazard in the northern Rocky Mountains, USA. In: Viegas, D.X., ed. III international conference on forest fire research/14th conference on fire and forest meteorology proceedings, volume II. Coimbra, Portugal: ADAI and University of Coimbra: 2517–2532.
- Scott, J.H. 1998e.** Using the Fire and Fuels Extension to the Forest Vegetation Simulator to assess long-term changes in crown fire hazard. In: Viegas, D.X., ed. III international conference on forest fire research/14th conference on fire and forest meteorology proceedings, volume II. Coimbra, Portugal: ADAI and University of Coimbra: 2621–2629.
- Scott, J.H. 1999.** NEXUS: a system for assessing crown fire hazard. Fire Management Notes. 59(2): 20–24.
- Scott, J.H. 2006.** Comparison of crown fire modeling systems used in three fire management applications. Res. Pap. RMRS-RP-58. Fort Collins, CO: U.S. Department of Agriculture, Forest Service, Rocky Mountain Research Station. 25 p.
- Scott, J.H. 2007.** Nomographs for estimating surface fire behavior characteristics. Gen. Tech. Rep. RMRS-GTR-192. Fort Collins, CO: U.S. Department of Agriculture, Forest Service, Rocky Mountain Research Station. 119 p.
- Scott, J.H.; Burgan, R.E. 2005.** Standard fire behavior fuel models: a comprehensive set for use with Rothermel's surface fire spread model. Gen. Tech. Rep. RMRS-GTR-155. Fort Collins, CO: U.S. Department of Agriculture, Forest Service, Rocky Mountain Research Station. 72 p.
- Scott, J.H.; Reinhardt, E.D. 2001.** Assessing crown fire potential by linking models of surface and crown fire behavior. Res. Pap. RMRS-RP-29. Fort Collins, CO: U.S. Department of Agriculture, Forest Service, Rocky Mountain Research Station. 59 p.
- Scott, J.H.; Reinhardt, E.D. 2005.** Stereo photo guide for estimating canopy fuel characteristics in conifer stands. Gen. Tech. Rep. RMRS-GTR-145. Fort Collins, CO: U.S. Department of Agriculture, Forest Service, Rocky Mountain Research Station. 49 p.
- Shields, H.J. 1969.** Helicopter rotor downwash effects. Spec. Rep. ED&T 1818. San Dimas, CA: U.S. Department of Agriculture, Forest Service, San Dimas Equipment Development Center. 13 p.
- Sibley, R.B. 1971.** A system for identifying unmanageable wildland fires. Ann Arbor, MI: University of Michigan. 139 p. Ph.D. dissertation.
- Simard, A.J.; Haines, D.A.; Blank, R.W.; Frost, J.S. 1983.** The Mack Lake Fire. Gen. Tech. Rep. NC-83. St. Paul, MN: U.S. Department of Agriculture, Forest Service, North Central Forest Experiment Station. 36 p.

- Simard, M.; Romme, W.H.; Griffin, J.M.; Turner, M.G. 2011.** Do mountain pine beetle outbreaks change the probability of active crown fire in lodgepole pine forests? *Ecological Monographs*. 81: 3–24.
- Skoworonski, N.S.; Clark, K.L.; Duveneck, M.; Hom, J. 2011.** Three-dimensional canopy fuel loading predicting using upward and downward sensing LiDAR systems. *Remote Sensing of Environment*. 115: 703–714.
- Slijepcevic, A.; Fogarty, L. 1998.** Reducing the influence of helicopter rotor wash on fire behaviour. *Fire Tech. Transfer Note 16*. Rotorua and Wellington, NZ: New Zealand Forest Research Institute and National Rural Fire Authority. 12 p.
- Small, R.T. 1957.** The relationships of weather factors to the rate of spread of the Robie Creek Fire. *Monthly Weather Review*. 85: 1–8.
- Stephens, S.L.; Boerner, R.E.J.; Moghaddas, J.J.; Moghaddas, E.E.Y.; Collins, B.M.; Dow, C.B.; Edminster, C.; Fiedler, C.E.; Fry, D.L.; Hartsough, B.R.; Keeley, J.E.; Knapp, E.E.; McIver, J.D.; Skinner, C.N.; Youngblood, A. 2012.** Fuel treatment impacts on estimated wildfire carbon loss from forests in Montana, Oregon, California, and Arizona. *Ecosphere*. 3(5), Article 38. 17 p.
- Stocks, B.J. 1987a.** Fire behavior in immature jack pine. *Canadian Journal of Forest Research*. 17: 80–86.
- Stocks, B.J. 1987b.** Fire potential in the spruce budworm-damaged forests of Ontario. *Forestry Chronicle*. 63: 8–14.
- Stocks, B.J. 1989.** Fire behavior in mature jack pine. *Canadian Journal of Forest Research*. 19: 783–790.
- Stocks, B.J.; Alexander, M.E.; Lanoville, R.A. 2004a.** Overview of the International Crown Fire Modelling Experiment (ICFME). *Canadian Journal of Forest Research*. 34: 1543–1547.
- Stocks, B.J.; Alexander, M.E.; Wotton, B.M.; Steffner, C.N.; Flannigan, M.D.; Taylor, S.W.; Lavoie, N.; Mason, J.A.; Hartley, G.R.; Maffey, M.E.; Dalrymple, G.N.; Blake, T.W.; Cruz, M.G.; Lanoville, R.A. 2004b.** Crown fire behaviour in a northern jack pine–black spruce forest. *Canadian Journal of Forest Research*. 34: 1548–1560.
- Stocks, B.J.; Flannigan, M.D. 1987.** Analysis of the behavior and associated weather for a 1986 northwestern Ontario wildfire: Red Lake No. 7. In: *Conference papers of the ninth conference on fire and forest meteorology*. Boston, MA: American Meteorological Society: 94–100.
- Stocks, B.J.; Hartley, G.R. 1995.** Fire behavior in three jack pine fuel complexes. [Poster with text.] Sault Ste. Marie, ON: Natural Resources Canada, Canadian Forest Service, Great Lakes Forestry Centre. <http://cfs.nrcan.gc.ca/pubwarehouse/pdfs/29043.pdf>. (29 January 2014).
- Stocks, B.J.; Mason, J.A.; Todd, J.B.; Bosch, E.M.; Wotton, B.M.; Amiro, B.D.; Flannigan, M.D.; Hirsch, K.G.; Logan, K.A.; Martell, D.L.; Skinner, W.R. 2002.** Large forest fires in Canada, 1959–1997. *Journal of Geophysical Research*. 108, D1: FFR5, 1–12.
- Storey, T.G.; Merkel, E.P. 1960.** Mortality in a longleaf-slash pine stand following a winter wildfire. *Journal of Forestry*. 58: 206–210.
- Stratton, R.D. 2006.** Guidance on spatial wildland fire analysis: models, tools, and techniques. Gen. Tech. Rep. RMRS-GTR-183. Fort Collins, CO: U.S. Department of Agriculture, Forest Service, Rocky Mountain Research Station. 15 p.
- Stratton, R.D. 2009.** Guidebook on LANDFIRE fuels data acquisition, critique, modification, maintenance, and model calibration. Gen. Tech. Rep. RMRS-GTR-220. Fort Collins, CO: U.S. Department of Agriculture, Forest Service, Rocky Mountain Research Station. 54 p.
- Strauss, D.; Bednar, L.; Mees, R. 1989.** Do one percent of forest fires cause ninety-nine percent of the damage? *Forest Science*. 35: 319–328.

- Sullivan, A.L. 2009a.** Improving operational models of fire behaviour. In: Anderssen, R.S.; Braddock, R.D.; Newham, L.T.H., eds. Proceedings of the 18th world IMACS congress and MODSIM09 international congress on modelling and simulation. Modelling and Simulation Society of Australia and New Zealand and International Association for Mathematics and Computers in Simulation: 282-288. <http://www.mssanz.org.au/modsim09/A4/sullivan.pdf> (14 February 2010).
- Sullivan, A.L. 2009b.** Wildland surface fire spread modelling, 1990–2007. 1: Physical and quasi-physical models. *International Journal of Wildland Fire*. 18: 349–368.
- Sullivan, A.L. 2009c.** Wildland surface fire spread modelling, 1990–2007. 2: Empirical and quasi-empirical models. *International Journal of Wildland Fire*. 18: 369–386.
- Sullivan, A.L.; McCaw, W.L.; Cruz, M.G.; Matthews, S.; Ellis, P.F. 2012.** Fuel, fire weather and fire behaviour. In: Bradstock, R.A.; Gill, A.M.; Williams, R.J., eds. *Flammable Australia: fire regimes, biodiversity and ecosystems in a changing world*. Melbourne, Victoria: CSIRO Publishing: 51–77.
- Sutton, M.W. 1984.** Extraordinary flame heights observed in pine fires on 16 February 1983. *Australian Forestry*. 47: 199–200.
- Taylor, D.F.; Williams, D.T. 1967.** Meteorological conditions of the Hellgate Fire. Res. Pap. SE-29. Asheville, NC: U.S. Department of Agriculture, Forest Service, Southeastern Forest Experiment Station. 12 p.
- Taylor, S.W.; Alexander, M.E. 2006.** Science, technology, and human factors in fire danger rating: the Canadian experience. *International Journal of Wildland Fire*. 15: 121–135.
- Taylor, S.W.; Pike, R.G.; Alexander, M.E. 1997.** Field guide to the Canadian Forest Fire Behavior Prediction (FBP) System. Spec. Publ. 11. Edmonton, AB: Natural Resources Canada, Canadian Forest Service, Northern Forestry Centre. 60 p.
- Taylor, S.W.; Wotton, B.M.; Alexander, M.E.; Dalrymple, G.N. 2004.** Variation in wind and crown fire behaviour in a northern jack pine—black spruce forest. *Canadian Journal of Forest Research*. 34: 1561–1576.
- Thomas, D.A. 1991.** The Old Faithful fire run of September 7, 1988. In: Andrews, P.L.; Potts, D.F., eds. Proceedings of 11th conference on fire and forest meteorology. SAF Publ. 91-04. Bethesda, MD: Society of American Foresters: 272–280.
- Thomas, D.A.; Leonard, D.A.; Miller, C. 2012.** The Fire Management Deep Smarts Project: interviews with key people involved with the Yellowstone fires of 1988 and with experts in returning natural fire to wilderness and National Park Service lands. Fort Collins, CO: USDA Forest Service, Rocky Mountain Research Station. <http://dx.doi.org/10.2737/RDS-2012-0010>. <http://www.fs.usda.gov/rds/archive/Product/RDS-2012-0010/>.
- Thomas, P.H. 1963.** The size of flames from natural fires. Symposium (international) on Combustion. 9: 844–859.
- Thomas, P.H. 1967.** Some aspects of the growth and spread of fire in the open. *Forestry*. 40: 139–164
- Thomas, P.H.; Simms, D.L.; Wraight, H.G.H. 1964.** Fire spread in wooden cribs. Fire Res Note No. 537. Boreham Wood, Herts, England: Department of Science and Industrial Research and Fire Offices' Commission, Joint Fire Research Organization, Fire Research Station. 38 p.
- Trevitt, C. 1989.** Ph.D. training and social responsibility in a changing climate—the roots of an educator's dilemma. *Climatic Change*. 14: 1–3.
- Tymstra, C.; Bryce, R.W.; Wotton, B.M.; Taylor, S.W.; Armitage, O.B. 2010.** Development and structure of Prometheus: the Canadian wildland fire growth simulation model. Inf. Rep. NOR-X-417. Edmonton, AB: Natural Resources Canada, Canadian Forest Service, Northern Forestry Centre. 102 p.
- Tymstra, C.; MacGregor, B.; Mayer, B. 2005.** The 2002 House River Fire. *Fire Management Today*. 65(1): 16–18.

U.S. Department of Agriculture, Forest Service

[USDA FS]. 1966. Stopping the big ones ... through fire research. Riverside, CA: U.S. Department of Agriculture, Forest Service, Pacific Southwest Forest and Range Experiment Station, Forest Fire Laboratory. 12 p.

U.S. Department of Agriculture, Forest Service

[USDA FS]. 1980. Report on the national fire behavior research conference. Washington, DC: Forest Fire and Atmospheric Sciences Research. 75 p. plus appendices.

U.S. Department of Agriculture, Forest Service. 1930.

Glossary of terms used in fire control. Misc. Publ. 70. Washington, DC. 22 p.

U.S. Department of Agriculture, Forest Service. 1956.

Glossary of terms used in forest fire control. Agric. Handb. 104. Washington, DC. 24 p.

Vaillant, N.M.; Fites-Kaufman, J. 2009. Using fuels and fire behavior to determine contributing factors for fire type [Extended abstract]. In: Masters, R.E.; Galley, K.E.M.; Despain, D.G., eds. The '88 fires: Yellowstone and beyond. Tall Timbers Misc. Publ. No. 16. Tallahassee, FL: Tall Timbers Research Station: 32.

Van de Water, K.; North, M. 2011. Stand structure, fuel loads, and fire behavior in riparian and upland forests, Sierra Nevada Mountains, USA; a comparison of current and reconstructed conditions. *Forest Ecology and Management*. 262: 215–228.

Van Wagner, C.E. 1964. History of a small crown fire. *Forestry Chronicle*. 40: 202–205, 208–209.

Van Wagner, C.E. 1965. Story of an intense crown fire at Petawawa. *Pulp and Paper Magazine of Canada Woodlands Review Section*. 66(8): 358–361.

Van Wagner, C.E. 1967a. Calculations on forest fire spread by flame radiation. Dep. Publ. 1185. Ottawa, ON: Canada Department of Forestry and Rural Development, Forestry Branch. 14 p.

Van Wagner, C.E. 1967b. Flammability of Christmas trees. Rev. ed. Dep. Publ. 1034. Ottawa, ON: Canada Department of Forestry and Rural Development, Forestry Branch. 27 p.

Van Wagner, C.E. 1967c. Seasonal variation in moisture content of eastern Canadian tree foliage and possible effect on crown fires. Dep. Publ. 1204. Ottawa, ON: Canada Department of Forestry and Rural Development, Forestry Branch. 15 p.

Van Wagner, C.E. 1968. Fire behaviour mechanisms in a red pine plantation: field and laboratory evidence. Dep. Publ. No. 1229. Ottawa, ON: Canada Department of Forestry and Rural Development, Forestry Branch. 30 p.

Van Wagner, C.E. 1969. A simple fire-growth model. *Forestry Chronicle*. 45: 103–104.

Van Wagner, C.E. 1971. Two solitudes in forest fire research. Inf. Rep. PS-X-29. Chalk River, ON: Environment Canada, Canadian Forestry Service, Petawawa Forest Experiment Station. 7 p.

Van Wagner, C.E. 1974. A spread index for crown fires in spring. Inf. Rep. PS-X-55. Chalk River, ON: Environment Canada, Canadian Forestry Service, Petawawa Forest Experiment Station. 10 p.

Van Wagner, C.E. 1977a. Conditions for the start and spread of crown fire. *Canadian Journal of Forest Research*. 7: 23–34.

Van Wagner, C.E. 1977b. Effect of slope on fire spread rate. *Canadian Forestry Service Bi-monthly Research Notes*. 33: 7–8.

Van Wagner, C.E. 1979a. Fuel variation in the natural fire-cycled boreal forest. In: Quintilio, D., comp. Proceedings of the international fire management workshop. Inf. Rep. NOR-X-215. Edmonton, AB: Environment Canada, Canadian Forestry Service, Northern Forest Research Centre: 67–69.

Van Wagner, C.E. 1979b. Meteorology and forest fire management. In: Proceedings of symposium on forest meteorology. WMO Publication No. 527. Geneva, Switzerland: World Meteorological Society: 102–107.

- Van Wagner, C.E. 1980.** Rough prediction of fire spread rates by fuel type. Rev. ed. Inf. Rep. PS-X-42. Chalk River, ON: Canadian Forestry Service, Petawawa Forest Experiment Station. 5 p.
- Van Wagner, C.E. 1983.** Fire behaviour in northern conifer forests and shrublands. In: Wein, R.W.; MacLean, D.A., eds. The role of fire in northern circumpolar ecosystems. SCOPE 18. Chichester, England: John Wiley & Sons: 65–80.
- Van Wagner, C.E. 1985.** Fire behavior modelling—how to blend art and science. In: Donoghue, L.R.; Martin, R.E., eds. Proceedings of the eighth conference on fire and forest meteorology. SAF Publ. 85-04. Bethesda, MD: Society of American Foresters: 3–5.
- Van Wagner, C.E. 1986.** Fire. In: Gourlay, J.F.; Borczon, E.L., eds. Managing red pine plantations. Toronto, ON: Ontario Ministry of Natural Resources: 27–35.
- Van Wagner, C.E. 1987.** Development and structure of the Canadian Forest Fire Weather Index System. For. Tech. Rep. 35. Ottawa, ON: Government of Canada, Canadian Forestry Service. 37 p.
- Van Wagner, C.E. 1989.** Prediction of crown fire behavior in conifer stands. In: MacIver, D.C.; Auld, H.; Whitewood, R., eds. Proceedings of the 10th conference on fire and forest meteorology. Ottawa, ON: Forestry Canada and Environment Canada: 207–212.
- Van Wagner, C.E. 1993.** Prediction of crown fire behavior in two stands of jack pine. Canadian Journal of Forest Research. 23: 442–449.
- Van Wagner, C.E. 1998.** Modelling logic and the Canadian Forest Fire Behavior Prediction System. Forestry Chronicle. 74: 50–52.
- Van Wagner, C.E. 1999.** Historical perspective of crown fire prediction. Paper presented at the National Interagency Fire Behavior workshop, Phoenix, AZ.; 12 p.
- van Wagtenonk, J.W. 2006.** Fire as a physical process. In: Sugihara, N.G.; van Wagtenonk, J.W.; Shaffer, K.E.; Fites-Kaufman, J.; Thode, A.E., eds. Fire in California's ecosystems. Berkeley: University of California Press: 38–57.
- van Wagtenonk, J.W.; Botti, S.J. 1984.** Modeling behavior of prescribed fires in Yosemite National Park. Journal of Forestry. 82: 479–484.
- Varner, J.M.; Keyes, C.R. 2009.** Fuels treatments and fire models: errors and corrections. Fire Management Today. 69(3): 47–50.
- Venkatesh, S.; Saito, K.; Rothermel, R.C. 2000.** Maximum spotting distance in wind-driven crown fires. Nensho no Kagaku to Gijutsu. 7: 221–233. [In English]
- Wade, D.D. 1981.** Some melaleuca fire relationships including recommendations for home site protection. In: Geiger, R.K., ed. Proceedings of melaleuca symposium. Tallahassee, FL: Florida Department of Agriculture and Consumer Services, Division of Forestry: 29–35.
- Wade, D.D.; Forbus, J.K.; Saveland, J.M. 1993.** Photo series for estimating post-hurricane residues and fire behavior in southern pine. Gen. Tech. Rep. SE-82. Asheville, NC: U.S. Department of Agriculture, Forest Service, Southeastern Forest Experiment Station. 19 p.
- Wade, D.D.; Ward, D.E. 1973.** An analysis of the Air Force Bomb Range Fire. Res. Pap. SE-105. Asheville, NC: U.S. Department of Agriculture, Forest Service, Southeastern Forest Experiment Station. 38 p.
- Watts, J.M., Jr. 1987.** Editorial: validating fire models. Fire Technology. 23: 93–94.
- Weber, M.G. 1995.** Fire research and the global village. Forestry Chronicle. 71: 584–588.
- Weber, M.G.; Hummel, M.; Van Wagner, C.E. 1987.** Selected parameters of fire behavior and *Pinus banksiana* Lamb. regeneration in eastern Ontario. Forestry Chronicle. 63: 340–346.
- Weber, R.O. 1991.** Modelling fire spread through fuel beds. Progress in Energy and Combustion Science. 17: 67–82.

- Weick, K.E. 2002.** Human factors in fire behavior analysis: reconstructing the Dude Fire. *Fire Management Today*. 62(4): 8–15.
- Wein, R.W. 1981.** Characteristics and suppression of fires in organic terrain in Australia. *Australian Forestry*. 44: 162–169
- Wendel, G.W. 1960.** Fuel weights of pond pine crowns. Res. Note 149. Asheville, NC: U.S. Department of Agriculture, Forest Service, Southeastern Forest Experiment Station. 2 p.
- Wendel, G.W.; Storey, T.G.; Byram, G.M. 1962.** Forest fuels on organic and associated soils in the Coastal Plain of North Carolina. Stn. Pap. 144. Asheville, NC: U.S. Department of Agriculture, Forest Service, Southeastern Forest Experiment Station. 46 p.
- Whitehead, R.J.; Russo, G.L.; Hawkes, B.C.; Armitage, O.B. 2007.** A silvicultural assessment of 10 lodgepole pine stands after partial cutting to reduce susceptibility to mountain pine beetle. Victoria, BC: Natural Resources Canada, Canadian Forest Service, Canadian Wood Fibre Centre. 48 p.
- Williams, D.T. 1969.** Unusual wind shifts of two wildfires. Res. Pap. SE-50. Asheville, NC: U.S. Department of Agriculture, Forest Service, Southeastern Forest Experiment Station. 8 p.
- Williams, J.T.; Rothermel, R.C. 1992.** Fire dynamics in Northern Rocky Mountain stand types. Res. Note INT-405. Ogden, UT: U.S. Department of Agriculture, Forest Service, Intermountain Research Station. 4 p.
- Wilson, C.C. 1977.** Fatal and near-fatal forest fires: the common denominators. *International Fire Chief*. 43(9): 9–10, 12–15.
- Wilson, C.C.; Davis, J.B. 1988.** Forest fire laboratory at Riverside and fire research in California: past, present, and future. Gen. Tech. Rep. PSW-105. Berkeley, CA: U.S. Department of Agriculture, Forest Service, Pacific Southwest Forest and Range Experiment Station. 22 p.
- Woodard, P.M.; Bentz, J.A.; Van Nest, T. 1983.** Producing a prescribed crown fire in a subalpine forest with an aerial drip torch. *Fire Management Notes*. 44(4): 24–28.
- Woodard, P.M.; Van Nest, T. 1990.** Winter burning bighorn sheep range—a proposed strategy. *Forestry Chronicle*. 66: 473–477.
- Woods, J.B., Jr. 1944.** Training manual for smokechasers, lookouts and suppression crews. Bull. 9. Salem, OR: Oregon State Board of Forestry. 99 p.
- Wotton, B.M.; Alexander, M.E.; Taylor, S.W. 2009.** Updates and revisions to the 1992 Canadian Forest Fire Behavior Prediction System. Inf. Rep. GLC-X-10. Sault Ste. Marie, ON: Natural Resources Canada, Canadian Forest Service, Great Lakes Forestry Centre. 45 p.
- Wotton, M. 2010.** The next generation of the Canadian Forest Fire Danger Rating System and implications for the international wildland fire community. In: Viegas, D.X., ed. Proceedings of the 6th international conference on forest fire research. [CD-ROM]. Coimbra, Portugal: University of Coimbra. 12 p.
- Xanthopoulos, G. 1990.** Development of a wildland crown fire initiation model. Missoula, MT: University of Montana. 152 p. Ph.D. thesis.
- Xanthopoulos, G.; Wakimoto, R.H. 1991.** Development of a wildland crown fire initiation model. In: Andrews, P.L.; Potts, D.F., eds. Proceedings of 11th conference on fire and forest meteorology. SAF Publ. 91-04. Bethesda, MD: Society of American Foresters: 281–290.
- Xanthopoulos, G.; Wakimoto, R.H. 1993.** A time to ignition-temperature-moisture relationship for branches of three western conifers. *Canadian Journal of Forest Research*. 23: 253–258.
- Zárate, L.; Arnaldos, J.; Casal, J. 2008.** Establishing safety distances for wildland fires. *Fire Safety Journal*. 43: 565–575.
- Zimmerman, G.T. 1990.** Ecological interrelationships of dwarf mistletoe and fire in lodgepole pine forests of Colorado. Fort Collins, CO: Colorado State University. 225 p. Ph.D. dissertation.

Acknowledgments

“This chapter is a contribution of Joint Fire Science Program (JFSP) Projects 09-2-01-11 and 09-S-03-1.

Dave Thomas (U.S. Forest Service, retired), Phil Omi (Professor Emeritus, Colorado State University), Mike Jenkins and Wesley Page (Utah State University), Chad Hoffman (University of Idaho), John Kern (Florida Division of Forestry), David Weise (U.S. Forest Service), Nicole Vailant (U.S. Forest Service), Bill Bereska (Alberta Sustainable

Resource Development, retired), Terry Van Nest (Alberta Sustainable Resource Development, retired), Bill Droog (Ontario Ministry of Natural Resources), Steve Jakala (U.S. Fish and Wildlife Service), Brad Armitage (Ember Research Services Ltd.), Charley Martin (U.S. Geological Survey), Sonny Stiger (FireSafe Montana), Mark Heathcott (formerly Parks Canada), Ross Wilmore (U.S. Forest Service), and Jason Loomis (Bureau of Land Management). The support of Mike Hilbruner (U.S. Forest Service, retired) is sincerely appreciated.”

Common and Scientific Names^a

Common name	Scientific name
Allepo pine	<i>Pinus halepensis</i> Mill. Show All Show Tabs
Black spruce	<i>Picea mariana</i> (Mill.) BSP
Douglas-fir	<i>Pseudotsuga menziesii</i> (Mirb.) Franco
Engelmann spruce	<i>Picea engelmannii</i> Parry ex Engelm.
Jack pine	<i>Pinus banksiana</i> Lamb.
Korean pine	<i>Pinus koraiensis</i>
Lodgepole pine	<i>Pinus contorta</i> Douglas ex. Louden
Maritime pine	<i>Pinus pinaster</i> Ait.
Monterey pine	<i>Pinus radiata</i> D. Don
Oak	<i>Quercus</i> spp.
Ponderosa pine	<i>Pinus ponderosa</i> C. Lawson
Red pine	<i>Pinus resinosa</i> Aiton
Sand pine	<i>Pinus clausa</i> (Chapm. ex Engelm.) Vasey ex Sarg
Scots pine	<i>Pinus sylvestris</i> L.
Singleleaf pinyon	<i>Pinus monophylla</i> Torr. & Frém.
Stone pine	<i>Pinus pinea</i> L.
Subalpine fir	<i>Abies lasiocarpa</i> (Hook) Nutt.
Utah juniper	<i>Juniperus osteosperma</i> (Torr.) Little
Western larch	<i>Larix occidentalis</i> Nutt.
White pine	<i>Pinus strobus</i> L.
White spruce	<i>Picea glauca</i> (Moench) Voss
Spruce	<i>Picea</i> spp.

^a Source: USDA NRCS 2010.

International System (SI)-to-US Customary Unit Conversion Factors

SI Unit	Conversion	US Customary Unit	Revers Conversion
Centimeters (cm)	$\times 0.394$	Inches (in)	$\times 2.54$
Degree Celsius ($^{\circ}\text{C}$)	$(9/5 \times ^{\circ}\text{C}) + 32$	Degree Fahrenheit ($^{\circ}\text{F}$)	$5/9 \times (^{\circ}\text{F} - 32)$
Gram (g)	$\times 0.0352$	Ounce (oz)	$\times 28.4$
HectoPascal (hPa)	$\times 0.030$	Inches of mercury (in Hg)	$\times 33.8$
HectoPascal (hPa)	$\times 1$	Millibar (mb)	$\times 1$
Hectare (ha)	$\times 2.47$	Acre (ac)	$\times 0.405$
Joule (J)	$\times 0.000948$	British thermal unit (Btu)	$\times 1050$
Joule per kilogram-degree C ($\text{J kg}^{-1} \text{ } ^{\circ}\text{C}^{-1}$)	$\times 0.000239$	Btu per pound-degree Fahrenheit ($\text{Btu lb}^{-1} \text{ } ^{\circ}\text{F}^{-1}$)	$\times 4180$
Joules per meter (J m^{-1})	$\times 0.000251$	Btu per foot (Btu ft^{-1})	$\times 3990$
Kelvins (K)	$[9/5 \times (\text{K} - 273)] + 32$	Degree Fahrenheit ($^{\circ}\text{F}$)	$5/9 \times (^{\circ}\text{F} - 32) + 273$
Kilogram (kg)	$\times 2.2$	Pound (lb)	$\times 0.455$
Kilogram per cubic meter (kg m^{-3})	$\times 0.0623$	Pound per cubic foot (lb ft^{-3})	$\times 16.0$
Kilogram per square meter (kg m^{-2})	$\times 0.204$	Pound per square foot (lb ft^{-2})	$\times 4.89$
Kilogram per square meter (kg m^{-2})	$\times 4.46$	Tons per acre (t ac^{-1})	$\times 0.224$
Kilojoule per kilogram (kJ kg^{-1})	$\times 0.431$	Btu per pound (Btu lb^{-1})	$\times 2.32$
Kilometer	$\times 0.621$	Mile (mi)	$\times 1.61$
Kilometer per hour (km h^{-1})	$\times 0.621$	Mile per hour (mi h^{-1})	$\times 1.6$
Kilowatt per meter (kW m^{-1})	$\times 0.290$	Btu per second-foot ($\text{Btu s}^{-1} \text{ ft}^{-1}$)	$\times 3.45$
Megawatt (MW)	$\times 948$	Btu per second (Btu s^{-1})	$\times 0.00105$
Megawatt per meter (MW m^{-1})	$\times 289$	Btu per second-foot ($\text{Btu s}^{-1} \text{ ft}^{-1}$)	$\times 0.003$
Meter (m)	$\times 3.28$	Foot (ft)	$\times 0.305$
Meter per minute (m min^{-1})	$\times 3.28$	Foot per minute (ft min^{-1})	$\times 0.305$
Meter per minute (m min^{-1})	$\times 2.98$	Chain per hour (ch h^{-1})	$\times 0.335$
Meter per second (m s^{-1})	$\times 3.28$	Feet per second (ft s^{-1})	$\times 0.305$
Number per hectare (no. ha^{-1})	$\times 0.405$	Number per acre (no. ac^{-1})	$\times 2.47$
Square meter (m^2)	$\times 10.76$	Square foot (ft^2)	$\times 0.093$
Square meter per hectare ($\text{m}^2 \text{ ha}^{-1}$)	$\times 4.36$	Square foot per acre ($\text{ft}^2 \text{ ac}^{-1}$)	$\times 0.23$

In accordance with Federal civil rights law and U.S. Department of Agriculture (USDA) civil rights regulations and policies, the USDA, its Agencies, offices, and employees, and institutions participating in or administering USDA programs are prohibited from discriminating based on race, color, national origin, religion, sex, gender identity (including gender expression), sexual orientation, disability, age, marital status, family/parental status, income derived from a public assistance program, political beliefs, or reprisal or retaliation for prior civil rights activity, in any program or activity conducted or funded by USDA (not all bases apply to all programs). Remedies and complaint filing deadlines vary by program or incident.

Persons with disabilities who require alternative means of communication for program information (e.g., Braille, large print, audiotape, American Sign Language, etc.) should contact the responsible Agency or USDA's TARGET Center at (202) 720-2600 (voice and TTY) or contact USDA through the Federal Relay Service at (800) 877-8339. Additionally, program information may be made available in languages other than English.

To file a program discrimination complaint, complete the USDA Program Discrimination Complaint Form, AD-3027, found online at http://www.ascr.usda.gov/complaint_filing_cust.html and at any USDA office or write a letter addressed to USDA and provide in the letter all of the information requested in the form. To request a copy of the complaint form, call (866) 632-9992. Submit your completed form or letter to USDA by: (1) mail: U.S. Department of Agriculture, Office of the Assistant Secretary for Civil Rights, 1400 Independence Avenue, SW, Washington, D.C. 20250-9410; (2) fax: (202) 690-7442; or (3) email: program.intake@usda.gov.

USDA is an equal opportunity provider, employer, and lender.



Federal Recycling Program
Printed on Recycled Paper

U.S. Department of Agriculture
Pacific Northwest Research Station
1220 SW 3rd Ave., Suite 1400
P.O. Box 3890
Portland, OR 97208-3890

Official Business
Penalty for Private Use, \$300